



Agenda

**Regular Meeting of the Public
Works and Utilities Committee
February 2, 2026 at 5:00 PM
Council Chambers, City Hall
200 Lincoln Avenue**

Procedures for Public Works and Utilities Committee Meeting

Viewing: *If the relevant technology is available to record the meeting in City Hall,* members of the public may stream the meeting live on the [City of Santa Fe's YouTube channel](#). The YouTube live stream can be accessed from most smartphones, tablets, or computers.

The video recording, *if created,* of this and all past meetings of the Public Works and Utilities Committee will also remain available for viewing at any time on the [City's YouTube channel](#). Staff is available to help members of the public access pre-recorded Governing Body meetings online at any time during normal business hours. Please call 955-6521 for assistance.

If relevant technology is available and functioning for City use, the following options may be available:

Virtual Public Comment: To provide public comment virtually, you must join the Zoom meeting by internet or phone, using the following link:

- Internet: [Join the Zoom](#) meeting on the internet using a computer, laptop, smartphone, or tablet. Attendees should use the "Raise Hand" function to be recognized by the Mayor to speak at the appropriate time.
- Phone: To join the Zoom meeting using a phone, use the following phone numbers and Webinar ID: US: - Webinar ID: Phone attendees should press *9 to use the "Raise Hand" function to be recognized by the Chair to speak at the appropriate time.

1. Call to Order
2. Roll Call
3. Approval of Agenda
4. Approval of Consent Agenda
5. Public Comment
6. Presentations
 - a. Public Utilities Department Employee of the Month for December 2025:

Marcos Armijo, Wastewater Management Division (Michael Dozier,
Wastewater Management Division Director; mldozier@santafenm.gov)

7. Action Items: Consent Agenda

- a. Request for Approval of the January 20, 2026, Public Works and Utilities Committee Meeting Minutes. (Elsa Ornelas-Segura, Administrative Manager; egornelassegura@santafenm.gov)

- b. Request for Approval of a General Services Contract with Andritz Separation Inc. in the Total Amount of \$771,319.52 Including NMGRT for Refurbishment of No 2 & No 3 Belt Filter Presses at the Wastewater Treatment Plant for a Two-Year Term. (Leroy Alvarado, Operations Superintendent; lmalvarado@santafenm.gov)

1. Request for Approval of a Budget Amendment Resolution (BAR) in the Total Amount of \$771,320 from Wastewater Enterprise Fund to WIP Construction.

Committee Review:

Public Works and Utilities Committee: 02/02/2026

Finance Committee: 02/09/2026

Governing Body: 02/11/2026

- c. Request for Approval of Capital Outlay Grant Agreement with the New Mexico Department of Finance and Administration in the Total Amount of \$260,000 for Project Completion of the Shelby Street Pedestrian Bridge Including Demolition and New Construction, Project 25-J5984 With a Reversion Date of April 11, 2027. (Scott Overlie, Public Works Project Manager III; saoverlie@santafenm.gov)

1. Request for Approval of a Budget Amendment Resolution (BAR) to Allocate \$260,000 from the 2025 Capital Appropriation to FY26 Revenue and WIP Construction.

Committee Review:

Public Works and Utilities Committee: 02/02/2026

Finance Committee: 02/09/2026

Governing Body: 02/11/2026

- d. Request for Approval to Purchase Two Roll-Off Collection Vehicles from Rush Truck Centers of New Mexico, Inc. in the Total Amount of \$548,338. (Martin Valdez, ESD Fleet Manager; mjvaldez@santafenm.gov)

Committee Review:

Public Works and Utilities Committee: 02/02/2026

Finance Committee: 02/09/2026

Governing Body: 02/11/2026

- e. Request for Approval of a Budget Amendment Resolution (BAR) in the Amount

Public Works and Utilities Committee

February 2, 2026

Page 2 of 4

of \$1,060,091 from Municipal Recreation Complex (MRC) Cash Balance to the Lodgers' Tax Fund to Reconcile Costs Associated with the Startup of the Golf Course Operating Agreement in FY24. (Phillip Lujan, MRC Business Manager; pmlujan@santafenm.gov)

Committee Review:

Public Works and Utilities Committee: 02/02/2026

Finance Committee: 02/09/2026

Governing Body: 02/11/2026

- f. Request for Approval of Amendment No. 2 to Professional Services Contract Item #24-0112 with WSP USA, Inc. for Owner's Representative Project Manager Services to Support Redevelopment at Midtown to Increase the Amount of Compensation by \$1,173,861 for a Total Compensation of \$5,083,861. (Carly Venditti, Metropolitan Redevelopment Agency Deputy Director; cavenditti@santafenm.gov)

Committee Review:

Public Works and Utilities Committee: 02/02/2026

Finance Committee: 02/09/2026

Governing Body: 02/11/2026

- g. CONSIDERATION OF RESOLUTION NO. 2026-____. (Councilor Amanda Chavez)
A Resolution Authorizing City of Santa Fe Representatives and Agents to Sign Agreements and Requests for Payment Regarding New Mexico Environment Department, for Grant Agreement Number SAP 25-J2459-GF to Plan, Design, and Construct a Wastewater Treatment Facility. (Carol Swenson, Business Operations Manager; yctswenson@santafenm.gov)

Committee Review:

Governing Body (Introduced): 01/28/2026

Public Works and Utilities Committee: 02/02/2026

Finance Committee: 02/09/2026

Governing Body: 02/11/2026

8. Action Items: Discussion Agenda
9. Executive Session
10. Matters from Staff
11. Matters from the Committee
12. Matters from the Chair
13. Next Meeting: Monday, February 16, 2026

14. Adjourn

Persons with disabilities in need of accommodations, contact the City Clerk's office at 955-6521, five (5) working days prior to meeting date.

**Regular Meeting of the Public Works and Utilities Committee
January 20, 2026 at 5:00 PM
Council Chambers, City Hall
200 Lincoln Avenue
MINUTES**

1. Call to Order

The Regular Meeting of the Public Works and Utilities Committee was called to order by Councilor Chavez at 5:02 PM, on Tuesday, January 20, 2026, in the Council Chambers, City Hall, 200 Lincoln Avenue, Santa Fe, New Mexico.

2. Roll Call

MEMBERS PRESENT

City Councilor, District 4, Chair Amanda Chavez

City Councilor, District 1 Patricia Feghali

City Councilor, District 2 Elizabeth Barrett

City Councilor, District 3 Pilar Faulkner

OTHER PARTICIPANTS ATTENDING

Sam Burnett, Interim Public Works Department Director

Jesse Roach, Interim Public Utilities Department Director

Taylor Jurgens, Public Utilities Engineer

3. Approval of Agenda

MOTION A motion was made by City Councilor, District 2 Barrett, seconded by City Councilor, District 1 Feghali, to Approve.

VOTE The motion Passed on a roll call vote.

4. Approval of Consent Agenda

Pulled Item EE

Recommendation was made by Chair Amanada Chavez that it go forward to Finance Committee.

MOTION A motion was made by Councilor Faulkner, seconded by City Councilor, District 2 Barrett, to Approve.

VOTE The motion Passed on a roll call vote.

5. Public Comment

Approved on Consent

6. Presentations

- a. Annual Update on the Water Division's Asset Management Plan. (Taylor

Jurgens, Engineer; trjurgens@santafenm.gov)

7. Action Items: Consent Agenda

Approved on Consent

- a. Request for Approval of the December 1, 2025, Public Works and Utilities Committee Meeting Minutes. (Daryn Lujan, Administrative Assistant; dmlujan@santafenm.gov)

Committee Review:

Public Works and Utilities Committee: 01/20/2026

Approved on Consent

- b. Request for Approval of a Budget Amendment Resolution (BAR) in the Total Amount of \$525,386 from the Available Water Division Cash Balance to Remodel and Replacement for the Remodel of the Carlos Ortega Center. (Christine Chavez, Water Conservation Manager; cychavez@santafenm.gov)

Committee Review:

Public Works and Utilities Committee: 01/20/2026

Finance Committee: 01/26/2026

Governing Body: 01/28/2026

Approved on Consent

- c. Request for Approval of General Services Contract with Brenntag Pacific, Inc. for the Purchase of a Chemical Aid to Enhance Settle Ability of Mixed Liquor Suspended Solids and Increase Phosphorus Removal within the Activated Sludge Wastewater Treatment Process in the Total Amount of \$4,000,000 for 4 Year Term. (Efren Morales, WWM Plant Manager; emmorrall@santafenm.gov)

1. Request for Approval of a Budget Amendment Resolution (BAR) in the Total Amount of \$1,000,000 From the Wastewater Enterprise Fund to Operating Supplies.

Committee Review:

Public Works and Utilities Committee: 01/20/2026

Finance Committee: 01/26/2026

Governing Body: 01/28/2026

Approved on Consent

- d. Request for Approval to Reauthorize the \$1,000,000 Budgeted in FY 2023-24 to Facilities WIP Construction for Security Camera Replacement to Allocate the Unspent Balance of \$426,831 to City Hall Security Improvements. (Tim Farrell, Interim Facilities Division Director; tgfarrell@santafenm.gov)

Committee Review:

Public Works and Utilities Committee: 01/20/2026
Finance Committee: 01/26/2026
Governing Body: 01/28/2026

Approved on Consent

- e. Request for Approval of an On-Call Price Agreement with HEI Inc. in the Total Amount of \$10,000,000 Including NMGR for Construction Services for a Two-Year Term. (Sebastian Gallegos, Project Manager; sfgallegos@santafenm.gov)

Committee Review:

Public Works and Utilities Committee: 01/20/2026
Finance Committee: 01/26/2026
Governing Body: 01/28/2026

Approved on Consent

- f. Request for Approval of Amendment No. 1 to General Services Contract Item #24-0487 with Systems Design West, LLC to Increase the Fixed Price for Each Deliverable Item to \$23.50 Per Transport for a Total Amount of \$300,000 Including NMGR for Year One, for Ambulance Service Billing. (Scott Ouderkirk, Interim Fire Chief; slouderkirk@santafenm.gov)

Committee Review:

Public Safety Committee: 01/20/2026
Public Works and Utilities Committee: 01/20/2026
Finance Committee: 01/26/2026
Governing Body: 01/28/2026

Approved on Consent

- g. Request for Approval of a Budget Amendment Resolution (BAR) in the Total Amount of \$158,624 to Professional Contracts from Reimbursements/Refunds Pursuant to the Terms of the Memorandum of Agreement between New Mexico Health Care Authority (HCA) to Pay Public Consulting Group a 14% Contingency Fee. (Scott Ouderkirk, Interim Fire Chief; slouderkirk@santafenm.gov)

Committee Review:

Public Works and Utilities Committee: 01/20/2026
Finance Committee: 01/26/2026
Governing Body: 01/28/2026

Approved on Consent

- h. Request for Approval to Purchase a Ferrara HD77 Ladder/Quint and Equipment Totaling \$1,670,000 with 411 Equipment, LLC. (Scott Ouderkirk, Interim Fire Chief; slouderkirk@santafenm.gov)

Committee Review:

Public Works and Utilities Committee: 01/20/2026

Public Safety Committee: 01/20/2026

Finance Committee: 01/26/2026

Governing Body: 01/28/2026

Approved on Consent

- i. Request for Approval to Purchase a 2025 Ferrara Custom Cinder Fire Engine/Pumper totaling \$980,043 with 411 Equipment, LLC. (Scott Ouderkirk, Interim Fire Chief; slouderkirk@santafenm.gov)

Committee Review:

Public Works and Utilities Committee: 01/20/2026

Public Safety Committee: 01/20/2026

Finance Committee: 01/26/2026

Governing Body: 01/28/2026

Approved on Consent

- j. Request for Approval of a Memorandum of Agreement with New Mexico Health Care Authority to Facilitate an Inter-Governmental Transfer of Funds for the Purpose of Participation in the NM Ambulance Supplemental Payment Program in the Total Amount of \$1,122,045.55. (Scott Ouderkirk, Interim Fire Chief; slouderkirk@santafenm.gov)

1. Request for Approval of Budget Amendment Resolution (BAR) to Allocate \$1,122,045.55 from Grant Proceeds Awarded to the Fire Department from the State of New Mexico Department of Finance and Administration.

Committee Review:

Public Works and Utilities Committee: 01/20/2026

Public Safety Committee: 01/20/2026

Finance Committee: 01/26/2026

Governing Body: 01/28/2026

Approved on Consent

- k. Request for Approval of an On-Call Price Agreement with Enviroworks LLC in the Total Amount of \$10,000,000 Including NMGRT for City-Wide Miscellaneous Construction Services for a Term of 10 Years. (Caryn Grosse, Public Works Project Manager III, clgrosse@santafenm.gov)

Committee Review:

Public Works and Utilities Committee: 01/20/2026

Finance Committee: 01/26/2026

Governing Body: 01/28/2026

Approved on Consent

- I. Request for Approval of an On-Call Price Agreement with LLR Construction LLC in the Total Amount of \$10,000,000 Including NMGR for City-Wide Miscellaneous Construction Services for a Term of 10 Years. (Caryn Grosse, Public Works Project Manager III; clgrosse@santafenm.gov)

Committee Review:

Public Works and Utilities Committee: 01/20/2026

Finance Committee: 01/26/2026

Governing Body: 01/28/2026

Approved on Consent

- m. Request for Approval of an On-Call Price Agreement with Unified Contractor, Inc. in the Total Amount of \$10,000,000 Including NMGR for City-Wide Miscellaneous Construction Services for a Term of 10 Years. (Caryn Grosse, Public Works Project Manager III; clgrosse@santafenm.gov)

Committee Review:

Public Works and Utilities Committee: 01/20/2026

Finance Committee: 01/26/2026

Governing Body: 01/28/2026

Approved on Consent

- n. Request for Approval of Capital Appropriation Grant Agreement with New Mexico Department of Finance and Administration for Project 25-J4371 Improvements to the South Side Teen Center in the Total Amount of \$1,764,580 with a Reversion Date of June 30, 2027. (Jake Martinez, Public Works Project Manager II; jemartinez@santafenm.gov)

Committee Review:

Public Works and Utilities Committee: 01/20/2026

Finance Committee: 01/26/2026

Governing Body: 01/28/2026

Approved on Consent

- o. Request for Approval of an On-Call Price Agreement with Davenport Construction Management LLC in the Total Amount of \$10,000,000 Including NMGR for City-Wide Miscellaneous Construction Services for a Term of 10 Years. (Caryn Grosse, Public Works Project Manager III; clgrosse@santafenm.gov)

Committee Review:

Public Works and Utilities Committee: 01/20/2026

Finance Committee: 01/26/2026

Governing Body: 01/28/2026

Approved on Consent

- p. Request for Approval of an On-Call Price Agreement with B&D Industries Inc. in the Total Amount of \$10,000,000 Including NMGR T for City-Wide Miscellaneous Construction Services for a Term of 10 Years. (Caryn Grosse, Public Works Project Manager III; clgrosse@santafenm.gov)

Committee Review:

Public Works and Utilities Committee: 01/20/2026

Finance Committee: 01/26/2026

Governing Body: 01/28/2026

Approved on Consent

- q. Request for Approval of an On-Call Price Agreement with AnchorBuilt Inc. in the Total Amount of \$10,000,000 Including NMGR T for City-Wide Miscellaneous Construction Services for a Term of 10 Years. (Caryn Grosse, Public Works Project Manager III; clgrosse@santafenm.gov)

Committee Review:

Public Works and Utilities Committee: 01/20/2026

Finance Committee: 01/26/2026

Governing Body: 01/28/2026

Approved on Consent

- r. Request for Approval of an On-Call Price Agreement with JDR & Associates in the Total Amount of \$10,000,000 Including NMGR T for City-Wide Miscellaneous Construction Services for a Term of 10 Years. (Caryn Grosse, Public Works Project Manager III; clgrosse@santafenm.gov)

Committee Review:

Public Works and Utilities Committee: 01/20/2026

Finance Committee: 01/26/2026

Governing Body: 01/28/2026

Approved on Consent

- s. Request for Approval of a Lease Agreement for Terminal Space with ARINC Incorporated for Five Years At \$6,408 Per Year. (Jimmy Gunn, Airport Security Coordinator; jdgunn@santafenm.gov Terry Lease, Asset Development Manager; tjlease@santafenm.gov)

Committee Review:

Public Works and Utilities Committee: 01/20/2026

Finance Committee: 01/26/2026

Governing Body: 01/28/2026

Approved on Consent

- t. Request for Approval of a General Services Contract with US Electrical Corp. in the Total Amount of \$540,938 Including NMGR T for City-Wide Elevator

Services with a Two-Year Term. (Caryn Grosse, Public Works Project Manager III, clgrosse@santafenm.gov)

Committee Review:

Public Works and Utilities Committee: 01/20/2026

Finance Committee: 01/26/2026

Governing Body: 01/28/2026

Approved on Consent

- u. Request for Approval of Amendment No. 1 to Professional Services Agreement Item #24-0483 with Wilson & Company, Inc. Engineers & Architects to Increase the Compensation by \$5,000,000 for a New Total Amount of \$10,000,000 excluding NMGR for On-Call General Engineering Services and Construction Management Services for the Design and Construction of Roadway, Trail, Drainage, Facility, Utility and Traffic Design. (Romella Glorioso-Moss, Capital Project Manager; rsglorioso-moss@santafenm.gov)

Committee Review:

Public Works and Utilities Committee: 01/20/2026

Finance Committee: 01/26/2026

Governing Body: 01/28/2026

Approved on Consent

- v. Request for Approval of Amendment No. 1 to Item #25-0425 with Bradbury Stamm Construction to Decrease Compensation by \$287,205.18 to Correct the GRT Percentage for a Total New Total Amount of \$23,386,708.13 including NMGR for Canyon Road Water Treatment Plant Flocculation and Sedimentation Improvements. (Clinton Peterson, Engineer; cdpeterson@santafenm.gov)

Committee Review:

Public Works and Utilities Committee: 01/20/2026

Finance Committee: 01/26/2026

Governing Body: 01/28/2026

Approved on Consent

- w. Request for Approval of a Budget Amendment Resolution (BAR) to Re-Appropriate \$137,416 of the Unspent FY25 One-Time Appropriation from the General Fund Balance to FY26 Public Works Administration Professional Contracts for Capital Program Management. (Sam Burnett, Interim Public Works Director; jsburnett@santafenm.gov)

Committee Review:

Public Works and Utilities Committee: 01/20/2026

Finance Committee: 01/26/2026

Governing Body: 01/28/2026

Approved on Consent

- x. Request for Approval of Amendment No. 1 to Construction Contract Item #25-0371 with Advanced Environmental Solutions, Inc. for Siler Complex Fuel Station Remediation to Extend the Term to March 31, 2026. (Marlisa Wilson, Public Works Project Manager; mbwilson@santafenm.gov)

Committee Review

Public Works and Utilities Committee: 01/20/2026

Finance Committee: 01/26/2026

Governing Body: 01/28/2026

Approved on Consent

- y. Request for Approval of Capital Appropriation Agreement with New Mexico Department of Transportation in the Total Amount of \$300,000 for Project C5223169 Improvements to Governor Miles Road from Richards Avenue to Nizhoni Drive with a Reversion Date of June 30, 2026. (Romella Glorioso-Moss, Complete Streets Capital Projects Manager, rsglorioso-moss@santafenm.gov)

1. Request for Approval of a Budget Amendment Resolution (BAR) to Allocate \$300,000 from the 2022 Capital Appropriation to FY26 Revenue and WIP Design.

Committee Review:

Public Works and Utilities Committee 01/20/2026

Finance Committee 01/26/2026

Governing Body 01/28/2026

Approved on Consent

- z. Request for Approval of Amendment No. 6 to Item # 18-0758 with Paymentus Corporation to Increase the Compensation by \$153,000 for a New Total Contract Amount of \$377,000, and Extend the Term through March 23, 2027, for Merchant Service Monthly Subscription Fee and Monthly Charge Fees for Returned Payments and Customer Disputes. (Nancy Jimenez, Utility Billing and Administration Division Director; nljimenez@santafenm.gov)

Committee Review:

Public Works and Utilities Committee: 01/20/2026

Finance Committee: 01/26/2026

Governing Body: 01/28/2026

Approved on Consent

- aa. Request for Approval of a Professional Services Agreement with New Mexico Grant Administration in the Total Amount of \$200,000 Including NMGRT for On

Call Infrastructure Capital Improvement Plan, Legislative Grant Administration, and Capital Program Management Services for a One-Year Term. (Sam Burnett, Interim Public Works Department Director; jsburnett@santafenm.gov)

Committee Review:

Public Works and Utilities Committee 01/20/2026

Finance Committee 01/26/2026

Governing Body 01/28/2026

Approved on Consent

- bb. Request for Approval of Amendment No. 1 to Item #24-0643 with Aquasight, LLC to Amend the Scope of Work and Increase the Compensation by \$28,656.25 for a New Total Contract Amount of \$378,656.25 to Account for Gross Receipt Tax for Software Services for the Paseo Real Wastewater Reclamation Facility. (Michael Dozier, WW Division Director; mldozier@santafenm.gov)

Committee Review:

Public Works and Utilities Committee: 01/20/2026

Finance Committee: 01/26/2026

Governing Body: 01/28/2026

Approved on Consent

- cc. Request for Approval of Capital Outlay Grant Agreement with New Mexico Environment Department for the Improvement of the Paseo Real Wastewater Treatment Facility Project SAP 25-J2459-GF in the Total Amount of \$100,000 With a Reversion Date of June 30, 2029. (Jesse Roach, Interim Public Utilities Department Director; jdroach@santafenm.gov)

- 1. Request for Approval of a Budget Amendment Resolution (BAR) to Allocate \$99,000 from the 2025 Capital Appropriation to FY26 Revenue and WIP Design for the Improvement of the Paseo Real Wastewater Treatment Facility.

Committee Review:

Public Works and Utilities Committee 01/20/2026

Finance Committee 01/26/2026

Governing Body 01/28/2026

Approved on Consent

- dd. Request for Approval of Amendment No. 1 to a Memorandum of Agreement with the New Mexico Department of Transportation (NMDOT) for Public Transportation Operating Assistance in the Total Amount of \$20,000 with a Reversion Date of March 31, 2027. (Gabrielle Chavez, Transit Director of Administration; gnchavez@santafenm.gov)

- 1. Request for Approval of a Budget Amendment Resolution (BAR) in the Total Amount of

\$40,000 to FY25 Transit Grant Revenue and Professional Contracts.

Committee Review:

Public Works and Utilities Committee: 01/20/2026

Finance Committee: 01/26/2026

Governing Body: 01/28/2026

Approved on Consent

- ee. CONSIDERATION OF BILL NO. 2025-26. ADOPTION OF ORDINANCE NO. 2026-____. (Mayor Alan Webber, Councilor Carol Romero-Wirth, Councilor Jamie Cassutt) A Bill Approving a Community Energy Efficiency Development (“CEED”) Block Grant From the New Mexico Energy Minerals and Natural Resources Department, Energy Conservation and Management Division, Pursuant to the “CEED Block Grant Act”, to Authorize a CEED Program Project and Approve the Terms and Conditions of the Grant Agreement. (Christine Chavez, Water Conservation Manager; cychavez@santafenm.gov, Erica N. Renaud, Sustainability Supervisor; enrenaud@santafenm.gov)

Committee Review:

Governing Body (Introduced): 12/10/2025

Governing Body (Public Comment): 01/15/2026

Public Works and Utilities Committee: 01/20/2026

Governing Body (Public Hearing): 02/11/2026

MOTION A motion was made by City Councilor, District 2 Barrett, seconded by City Councilor, District 1 Feghali, to Approve.

VOTE The motion Passed on a roll call vote.

- ff. CONSIDERATION OF RESOLUTION NO. 2026-____. (Mayor Alan Webber and Councilor Jamie Cassutt)
A Resolution Adopting Annual Open Meetings Act Notice Standards For 2026. (Geralyn Cardenas, Interim City Clerk; gfcardenas@santafenm.gov)

Committee Review:

Governing Body (Introduced): 12/10/2025

Public Works and Utilities Committee: 01/20/2026

Quality of Life Committee: 01/21/2026

Finance Committee: 01/26/2026

Governing Body: 01/28/2026

Approved on Consent

- gg. CONSIDERATION OF BILL NO. 2025-23. ADOPTION OF ORDINANCE NO. 2026-____.(Councilor Jamie Cassutt and Councilor Pilar Faulkner)
A Bill Amending SFCC 1987, Section 2-4.2, to Require City Managers to Be International City Manager Association (“ICMA”) – Credentialed or Credential-Eligible Unless an Appointment and Consent of Such a Candidate Is Not

Possible After Five Months; Requiring Candidates for Deputy City Manager to Have the Same Qualifications Pursuant to Section 2-4.6(L); Removing Portions of Section 2-4.3 That Conflict With City Charter; and Removing the Prohibition for an Acting City Manager to Employ and Discharge Personnel. (Marci Eannarino, Legislation and Policy Innovation Manager; maeannario@santafenm.gov, Christine Spiers, Legislative Assistant; cmspiers@santafenm.gov, Palmer Anderson, Policy Analyst; pcanderson@santafenm.gov)

Committee Review:

Governing Body (Introduced): 12/10/2025
Governing Body (Public Comment): 01/15/2026
Public Works and Utilities Committee: 01/20/2026
Quality of Life Committee: 01/21/2026
Finance Committee: 01/26/2026
Governing Body: 02/11/2026

Approved on Consent

- hh. CONSIDERATION OF RESOLUTION NO. 2026-____. (Councilor Amanda Chavez and Councilor Jamie Cassutt)
A Resolution Directing the City Manager to Obtain an Updated Appraisal and Negotiate a Sales Price for Potential Acquisition of 122.634 Acres of Land Adjacent to the Paseo Real Water Reclamation Facility. (Jesse Roach, Interim Public Utilities Director; jdroach@santafenm.gov)

Committee Review:

Governing Body (Introduced): 01/15/2026
Public Works and Utilities Committee: 01/20/2026
Finance Committee: 01/26/2026
Governing Body: 01/28/2026

Approved on Consent

8. Action Items: Discussion Agenda
9. Executive Session
10. Matters from Staff
11. Matters from the Committee
12. Matters from the Chair
13. Next Meeting: Monday, February 2, 2026
14. Adjourn

Meeting Adjourned at 5:22 p.m.

Liaison

Chair

The Purchasing Memo

Date: December 29, 2025

To: Governing Body, Finance Committee, and Public Works & Utilities Committee

From: Leroy Alvarado Operations Superintendent LeRoy Alvarado
LeRoy Alvarado (Dec 29, 2025 14:06:49 MST)

Via: Michael Dozier, Wastewater Management Division Director 

Via: Jesse Roach, Acting Public Utilities Department Director 

Subject: Refurbishment of No.2 & No.3 Belt Filter Presses

Vendor Name: Andritz Separation Inc.

Munis Vendor Number: 3122

ITEM AND ISSUE:

The Wastewater Management Division respectfully requests your review and approval of this General Services Contract between City of Santa Fe and Andritz Separation, Inc. to refurbish No.2 & No.3 Belt filter presses. The compensation total amount of \$771,319.52 including tax on labor for a term of 2 years.

Request for Approval of a Budget Adjustment Resolution (BAR) in the amount of \$771.320 from WW Enterprise fund to WIP Construction.

CONTRACT NUMBER: 3260277

BACKGROUND AND SUMMARY:

In the recent past a maintenance service was performed on all three presses by Andritz service technicians. During this service visit the units were inspected, and minor repairs were completed. Findings from the inspection confirmed that major repairs were needed for all three units due to the lack of maintenance. The Wastewater Management Division (WWMD) is deciding to focus repairs on units No.2 and no.3 because of the similarity of construction (installation date 2018). No.1 is original equipment (installation date 2007). The WWMD will be evaluating other technologies to possibly replace No.1 press. It is in the best interest of the City of Santa Fe to thoroughly service these two belt filter presses through the original manufacturer of the equipment to ensure that there are no major issues during the rehabilitation of these units. If the wastewater treatment plant personnel are unable to operate these belt filter presses, this can create a backlog of biosolids. This backlog can bottleneck the treatment process that must waste (remove) a portion of biosolids every day out of the treatment stream to ensure proper treatment concentrations. Failing this process allows solids to exit the plant in the effluent and causes regulatory compliance violations and potentially a health and safety hazard to the public and environment. This work is part of the short-term goals that are being addressed in response to the administrative order submitted by the United State Environmental Protection Agency Docket Number: CWA-06-2024-1765; NPDES Permit Number: NM0022292

PRIOR APPROVALS AND SUPPORTING INFORMATION:

FUNDING SOURCE:

Fund Name/Number: WW Enterprise/500

Munis Org Name/Number: WW – Capital Projects 5000375

Munis Object Name/Number: WIP Const/572970

Budget Officer / Designee: Andy Hopkins **Date:** 01/15/2026

Budget Officer Comment/Exceptions: _____

PROCUREMENT METHOD:

The procurement method used was NMSA 1978, Section 13-1-102, ITB

Chief Procurement Officer (CPO)/Designee: JoAnn Lovato Montano **Date:** 01/15/2026

CPO Comment/Exceptions: ITB# 26024

ASSOCIATED APPROVALS:

IT Components included? Yes | No

Approval: _____ **Title:** _____ **Date:** _____

Comment/Exceptions: _____

Treasury/Point of Sale Components included? Yes | No

Approval: _____ **Title:** _____ **Date:** _____

Comment/Exceptions: _____

Vehicles included? Yes | No

Approval: _____ **Title:** _____ **Date:** _____

Comment/Exceptions: _____

Construction to City Facilities, Furniture, and/or Fixtures included? Yes | No

Approval: _____ **Title:** _____ **Date:** _____

Comment/Exceptions: _____

Is this an externally funded purchase? Yes | No

If yes, what is the issuing agency: _____

Approval: _____ **Title:** _____ **Date:** _____

Comment/Exceptions: _____

Is this a Capital Asset or Project? Yes | No

Project Ledger Number: n/a

Approval: _____ **Title:** _____ **Date:** _____

Comment/Exceptions: _____

ATTACHMENTS:

- Rate sheet
- COI
- Contract
- Determination

**CITY OF SANTA FE
GENERAL SERVICES CONTRACT**

BELT FILTER PRESSES REFURBISHMENT

THIS CONTRACT is made and entered into by and between the City of Santa Fe, herein after referred to as the "City," and **Andritz Separation, Inc.** herein after referred to as the "Contractor."

IT IS MUTUALLY AGREED BETWEEN THE PARTIES:

1. Definitions

- A. "Products and Services Schedule" refers to the complete list of products and services offered under this Contract and the price for each. Product and service descriptions may be amended with the prior approval of the Contract Administrator. New products and services shall not be added to the Products and Services Schedule.
- B. "Business Hours" means 8:00 a.m. to 5:00 p.m. Mountain Time.
- C. "Fiscal Year" means the twelve-month period beginning on July 1 and ending on June 30 of the following calendar year.
- D. "Fiscal Year Quarters" means the four three-month periods within the City's fiscal year, defined as follows: Quarter 1 is July 1 through September 30; Quarter 2 is October 1 through December 31; Quarter 3 is January 1 through March 31; and Quarter 4 is April 1 through June 30.

2. Scope of Work

The Contractor shall perform the following work: **See Exhibit A**

3. Compensation

- A. Payment. The City shall compensate the Contractor based on the itemized amounts and/or rates specified in Exhibit B.

For the services described in the scope of work, the City agrees pay the Contractor	\$ <u>755,228.00</u>
The services in the contract include GRT. The GRT on this contract at 8.1875% equals	+ \$ <u>44,573.08</u>
The total compensation for the contract including GRT is	= \$ <u>799,801.08</u>

- B. The compensation represents a maximum amount. The Contractor must notify the City when the Services provided under this Contract approach 90% of compensation total. Services rendered beyond the maximum compensation amount will not be reimbursed unless the Contract is amended in writing prior to the provision of such services.
- C. Invoicing and Payment Terms Payment will be made upon the City's acceptance of deliverables and receipt of a detailed, certified invoice from the Contractor. Payments will be sent to the Contractor's designated address. The City shall issue payment in accordance with the timelines required by law. Invoices must be submitted no later than fifteen (15) days after the Contract's termination. Late invoices will not be processed or paid.

4. **Term**

THIS CONTRACT SHALL NOT BECOME EFFECTIVE UNTIL APPROVED BY THE CITY.

This Contract shall terminate two (2) year from the date of final signature unless terminated pursuant to Paragraph 4 (Termination) or Paragraph 5 (Appropriations).

5. **Default and Force Majeure**

The City reserves the right to cancel all, or any part of any orders placed under this contract without cost to the City, if the Contractor fails to meet the provisions of this contract and, except as otherwise provided herein, to hold the Contractor liable for any excess cost occasioned by the City due to the Contractor's default. The Contractor shall not be liable for any excess costs if failure to perform the order arises out of causes beyond the control and without the fault or negligence of the Contractor; such causes include, but are not restricted to, acts of God or the public enemy, acts of the State or Federal Government, fires, floods, epidemics, quarantine restrictions, strikes, freight embargoes, unusually severe weather and defaults of sub-contractors due to any of the above, unless the City shall determine that the supplies or services to be furnished by the sub-contractor were obtainable from other sources in sufficient time to permit the Contractor to meet the required delivery scheduled. The rights and remedies of the City provided in this paragraph shall not be exclusive and are in addition to any other rights now being provided by law or under this contract.

6. **Termination**

A. **Grounds.** The City may terminate this Contract for convenience or cause. For contracts within their authority, the City Manager or their designee is authorized to provide the notice of termination, otherwise such notice of termination shall be provided by the Mayor, or their designee as authorized by the Governing Body. The Contractor may only terminate this Contract based upon the City's uncured material breach of this Contract.

B. **Notice: City Opportunity to Cure.**

- i) The City shall give the Contractor written notice of termination at least thirty (30) days prior to the intended date of termination.
- ii) Contractor shall give City written notice of termination at least thirty (30) days prior to the intended date of termination, which notice shall (i) identify all the City's material breaches of this Contract upon which the termination is based and (ii) state what the City must do to cure such material breaches. Contractor's notice of termination shall only be effective (i) if the City does not cure all material breaches within the thirty (30) day notice period or (ii) in the case of material breaches that cannot be cured within thirty (30) days, the City does not, within the thirty (30) day notice period, notify the Contractor of its intent to cure and begin with due diligence to cure the material breach.

iii) Notwithstanding the foregoing, this Contract may be terminated immediately upon written notice to the Contractor (i) if the Contractor becomes unable to perform the services contracted for, as determined by the City; (ii) if, during the term of this Contract, the Contractor is suspended or debarred by the City; or (iii) the Contract is terminated pursuant to Paragraph 17, "Appropriations", of this Contract.

C. **Liability.** Except as otherwise expressly allowed or provided under this Contract, the City's sole liability upon termination shall be to pay for acceptable work performed prior to the Contractor's receipt or issuance of a notice of termination; provided, however, that a notice of termination shall not nullify or otherwise affect either party's liability for pre-termination defaults under or breaches of this Contract. The Contractor shall submit an invoice for such work within thirty (30) days of receiving or sending the notice of termination. THIS PROVISION IS NOT EXCLUSIVE AND DOES NOT WAIVE THE CITY'S OTHER LEGAL RIGHTS AND REMEDIES CAUSED BY THE CONTRACTOR'S DEFAULT/BREACH OF THIS CONTRACT.

7. **Amendment**

A. This Contract shall not be altered, changed, or amended except by instrument in writing executed by the parties hereto and all other required signatories.

B. If the City proposes an amendment to the Contract to unilaterally reduce funding due to budget or other considerations, the Contractor shall, within thirty (30) days of receipt of the proposed Amendment, have the option to terminate the Contract, pursuant to the termination provisions as set forth in Paragraph 7 herein, or to agree to the reduced funding.

8. **Status of Contractor**

The Contractor, and Contractor's agents and employees, are independent Contractors for the City and are not employees of the City. The Contractor, and Contractor's agents and employees, shall not accrue leave, retirement, insurance, bonding, use of City vehicles, or any other benefits afforded to employees of the City because of this Contract. The Contractor acknowledges that all sums received hereunder are personally reportable by the Contractor for income tax purposes, including without limitation, self-employment tax and business income tax. The Contractor agrees not to purport to bind the City unless the Contractor has written authority to do so, and then only within the strict limits of that authority.

9. **Assignment**

The Contractor shall not assign or transfer any interest in this Contract or assign any claims for money due or to become due under this Contract without the prior written approval of the City.

10. **Subcontracting**

The Contractor shall not subcontract any portion of the services to be performed under this Contract without the prior written approval of the City. No such subcontract shall relieve the primary Contractor from its obligations and liabilities under this Contract, nor shall any subcontract obligate direct payment from the City.

11. **Non-Collusion**

In signing this Contract, the Contractor certifies the Contractor has not, either directly or indirectly, entered into action in restraint of free competitive bidding in connection with this offer submitted to the City.

12. Inspection of Plant

The City may inspect, at any reasonable time during Contractor's regular business hours and upon prior written notice, the Contractor's plant or place of business, or any subcontractor's plant or place of business, which is related to the performance of this contract.

13. Commercial Warranty

The Contractor agrees that the tangible personal property or services furnished under this Contract shall be covered by the most favorable commercial warranties the Contractor gives to any customer for such tangible personal property or services, and that the rights and remedies provided herein shall extend to the City and are in addition to and do not limit any rights afforded to the City by any other clause of this order. The contractor agrees not to disclaim warranties of fitness for a particular purpose or merchantability.

14. Condition of Proposed Items

Where tangible personal property is a part of this Contract, all proposed items are to be NEW and of most current production, unless otherwise specified.

15. Records and Audit

During the term of this Contract and for three years thereafter, the Contractor shall maintain detailed records pertaining to the services rendered and products delivered. These records shall be subject to inspection by the City, the State Auditor and other appropriate state and federal authorities. The City shall have the right to audit billings both before and after payment. Payment under this Contract shall not foreclose the right of the City to recover excessive or illegal payments.

16. Appropriations

The terms of this Contract, and any orders placed under it, are contingent upon sufficient appropriations and authorization being made by the Governing Body for the performance of this Contract. If sufficient appropriations and authorization are not made by the Governing Body, this Contract, and any orders placed under it, shall terminate upon written notice being given by the City to the Contractor. The City's decision as to whether sufficient appropriations are available shall be accepted by the Contractor and shall be final. If the City proposes an amendment to the Contract to unilaterally reduce funding, the Contractor shall have the option to terminate the Contract or to agree to the reduced funding, within thirty (30) days of receipt of the proposed amendment.

17. Release

The Contractor, upon final payment of the amount due under this Contract, releases the City, its officers, and employees, from all liabilities, claims and obligations whatsoever arising from or under this Contract. The Contractor agrees not to purport to bind the City, unless the Contractor has express written authority to do so, and then only within the strict limits of that authority.

18. Confidentiality

Any confidential information provided to or developed by the Contractor in the performance of this Contract shall be kept confidential and shall not be made available to any individual or organization by the Contractor without prior written approval by the City.

19. Conflict of Interest

A. The Contractor represents and warrants that it presently has no interest and, during the term of this Contract, shall not acquire any interest, direct or indirect, which would conflict in any manner or degree with the performance or services required under the Contract. The Contractor shall comply with any applicable provisions of the New Mexico Governmental Conduct Act and the New Mexico Financial Disclosures Act.

B. The Contractor further represents and warrants that it has complied with, and, during the term of this Contract, will continue to comply with, and that this Contract complies with all applicable provisions of the Governmental Conduct Act, NMSA 1978, Chapter 10, Article 16.

C. Contractor's representations and warranties in Paragraphs A and B of this Paragraph are material representations of fact upon which the City relied when this Contract was entered into by the parties. Contractor shall provide immediate written notice to the City if, at any time during the term of this Contract, Contractor learns that Contractor's representations and warranties in Paragraphs A and B of this Paragraph 20 were erroneous on the effective date of this Contract or have become erroneous by reason of new or changed circumstances. If it is later determined that Contractor's representations and warranties in Paragraphs A and B of this Paragraph 20 were erroneous on the effective date of this Contract or have become erroneous by reason of new or changed circumstances, in addition to other remedies available to the City and notwithstanding anything in the Contract to the contrary, the City may immediately terminate the Contract.

D. All terms defined in the Governmental Conduct Act have the same meaning in this section.

20. Approval of Contractor Representatives

The City reserves the right to require a change in the Contractor's assigned representatives if they are not adequately serving the City's needs.

21. Scope of Contract; Merger

This Contract incorporates all the agreements, covenants, and understandings between the parties hereto concerning the subject matter hereof, and all such covenants, agreements, and understandings have been merged into this written contract.

All terms and conditions of the **ITB** and the Contractor's response to such document(s) are incorporated herein by reference and is included in the order of precedence.

22. Notice

The Procurement Code, NMSA 1978, Sections 13-1-28 through 13-1-199, imposes civil and criminal penalties for its violation. In addition, the New Mexico criminal statutes impose felony penalties for bribes, gratuities, and kickbacks.

23. Equal Opportunity Compliance

The Contractor agrees to abide by all federal and state laws, and local Ordinances, pertaining to equal employment opportunity. In accordance with all such laws, rules, and regulations, the Contractor agrees to assure that no person in the United States shall on the grounds of race, religion, color, national origin, ancestry, sex, age, physical or mental handicap, or serious medical condition, spousal affiliation, sexual orientation or gender identity, be excluded from employment with or participation in, be denied the benefits of, or be otherwise subjected to discrimination under any program or activity performed under this Contract. If Contractor is found not to be in compliance with these requirements during the life of this Contract, Contractor agrees to take appropriate steps to correct these deficiencies.

24. Indemnification

The Contractor shall hold the City and its employees harmless and shall indemnify the City and its employees against any and all claims, suits, actions, liabilities and costs of any kind, including attorney's fees for personal injury or damage to property arising from the acts or omissions of the Contractor, its agents, officers, employees or subcontractors. The Contractor shall not be liable for any injury or damage as a result of any negligent act or omission committed by the City, its officers or employees.

25. New Mexico Tort Claims Act

Any liability incurred by the City of Santa Fe in connection with this Contract is subject to the immunities and limitations of the New Mexico Tort Claims Act, NMSA 1978, Section 41-4-1, et. seq., as amended. The City and its “public employees” as defined in the New Mexico Tort Claims Act, do not waive sovereign immunity, do not waive any defense and do not waive any limitation of liability pursuant to law. No provision in this Contract modifies or waives any provision of the New Mexico Tort Claims Act.

26. Applicable Law

The laws of the State of New Mexico shall govern this Contract, without giving effect to its choice of law provisions. Venue shall be proper only in a New Mexico court of competent jurisdiction in accordance with NMSA 1978, Section 38-3-2. By execution of this Contract, Contractor acknowledges and agrees to the jurisdiction of the courts of the State of New Mexico over any and all lawsuits arising under or out of any term of this Contract.

27. Limitation of Liability

The Contractor's liability to the City, for any cause whatsoever shall be limited to the purchase price paid to the Contractor for the products and services that are the subject of the City’s claim. The foregoing limitation does not apply to paragraph 25 of this Contract or to damages resulting from personal injury caused by the Contractor's negligence.

28. Incorporation by Reference and Precedence

If this Contract has been procured pursuant to a request for proposals, this Contract is derived from (1) the request for proposal, (including any written clarifications to the request for proposals and any City response to questions); (2) the Contractor's best and final offer; and (3) the Contractor's response to the request for proposals.

In the event of a dispute under this Contract, applicable documents will be referred to for the purpose of clarification or for additional detail in the following order of precedence: (1) amendments to the Contract in reverse chronological order; (2) the Contract, including the scope of work and all terms and conditions thereof; (3) the request for proposals, including attachments thereto and written responses to questions and written clarifications; (4) the Contractor's best and final offer if such has been made and accepted by the City; and (5) the Contractor's response to the request for proposals.

29. Workers' Compensation

The Contractor agrees to comply with state laws and rules applicable to workers' compensation benefits for its employees. If the Contractor fails to comply with the Workers' Compensation Act and applicable rules when required to do so, this Contract may be terminated by the City.

30. Inspection

If this contract is for the purchase of tangible personal property (goods), final inspection and acceptance shall be made at Destination. Tangible personal property rejected at Destination for non-conformance to specifications shall be removed at Contractor's risk and expense promptly after notice of rejection and shall not be allowable as billable items for payment.

31. Inspection of Services

If this contract is for the purchase of services, the following terms shall apply.

- A. Services, as used in this Article, include services performed, workmanship, and material furnished or utilized in the performance of services.
- B. The Contractor shall provide and maintain an inspection system acceptable to the City covering the services under this Contract. Complete records of all inspection work performed by the Contractor shall be maintained and made available to the City and for as long thereafter as the Contract requires. The City has the right to inspect and test all services contemplated under this Contract to the extent practicable at all times and places during the term of the Contract. The City shall perform inspections and tests in a manner that will not unduly delay or interfere with Contractor's performance.
- C. If the City performs inspections or tests on the premises of the Contractor or a subcontractor, the Contractor shall furnish, and shall require subcontractors to furnish, at no increase in contract price, all reasonable facilities and assistance for the safe and convenient performance of such inspections or tests.
- D. If any part of the services do not conform with the requirements of this Contract, the City may require the Contractor to re-perform the services in conformity with the requirements of this Contract at no increase in contract amount. When the defects in services cannot be corrected by re-performance, the City may:
 - i. require the Contractor to take necessary action(s) to ensure that future performance conforms to the requirements of this Contract; and
 - ii. reduce the contract price to reflect the reduced value of the services performed.

- E. If the Contractor fails to promptly re-perform the services or to take the necessary action(s) to ensure future performance in conformity with the requirements of this Contract, the City may:
- iv) by contract or otherwise, perform the services and charge to the Contractor any cost incurred by the City that is directly related to the performance of such service; or
 - v) terminate the contract for default.

32. Insurance

If the services contemplated under this Contract will be performed on or in City facilities or property, Contractor shall maintain in force during the entire term of this Contract, the following insurance coverage(s), naming the City as additional insured.

A. Commercial General Liability insurance shall be written on an occurrence basis and be a broad as ISO Form CG 00 01 with limits not less than \$2,000,000 per occurrence and \$2,000,000 in the aggregate for claims against bodily injury, personal and advertising injury, and property damage. Said policy shall include broad form Contractual Liability coverage and be endorsed to name the City of Santa Fe their officials, officers, employees, and agents as additional insureds.

B. Broader Coverage and Limits. The insurance requirements under this Contract shall be the greater of (1) the minimum coverage and limits specified in this Contract, or (2) the broader coverage and maximum limits of coverage of any insurance policy or proceeds available to the Named Insured. It is agreed that these insurance requirements shall not in any way act to reduce coverage that is broader or that includes higher limits than the minimums required herein. No representation is made that the minimum insurance requirements of this Contract are sufficient to cover the obligations of Contractor hereunder.

C. Contractor shall maintain the above insurance for the term of this Contract and name the City as an additional insured and provide for 30 days cancellation notice on any Certificate of Insurance form furnished by Contractor. Such certificate shall also specifically state the coverage provided under the policy is primary over any other valid and collectible insurance and provide a waiver of subrogation.

33. Impracticality of Performance

A party shall be excused from performance under this Contract for any period that the party is prevented from performing as a result of an act of God, strike, war, civil disturbance, epidemic, or court order, provided that the party has prudently and promptly acted to take any and all steps that are within the party's control to ensure performance. Subject to this provision, such non-performance shall not be deemed a default or a ground for termination.

34. Invalid Term or Condition

If any term or condition of this Contract shall be held invalid or unenforceable, the remainder of this Contract shall not be affected and shall be valid and enforceable.

35. Enforcement of Contract

A party's failure to require strict performance of any provision of this Contract shall not

waive or diminish that party's right thereafter to demand strict compliance with that or any other provision. No waiver by a party of any of its rights under this Contract shall be effective unless express and in writing, and no effective waiver by a party of any of its rights shall be effective to waive any other rights.

36. Patent, Copyright and Trade Secret Indemnification

A. The Contractor shall defend, at its own expense, the City against any claim that any product or service provided under this Contract infringes any patent, copyright to trademark in the United States or Puerto Rico, and shall pay all costs, damages and attorneys' fees that a court finally awards as a result of any such claim. In addition, if any third party obtains a judgment against the City based upon Contractor's trade secret infringement relating to any product or services provided under this Contract, the Contractor agrees to reimburse the City for all costs, attorneys' fees and amount of the judgment. To qualify for such defense and or payment, the City shall:

- i. give the Contractor prompt written notice within 48 hours of any claim;
- ii. allow the Contractor to control the defense of settlement of the claim; and
- iii. cooperate with the Contractor in a reasonable way to facilitate the defense or settlement of the claim.

B. If any product or service becomes, or in the Contractor's opinion is likely to become the subject of a claim of infringement, the Contractor shall at its option and expense:

- i. provide the City the right to continue using the product or service and fully indemnify the City against all claims that may arise out of the City's use of the product or service;
- ii. replace or modify the product or service so that it becomes non-infringing; or,
- iii. accept the return of the product or service and refund an amount equal to the value of the returned product or service, less the unpaid portion of the purchase price and any other amounts, which are due to the Contractor. The Contractor's obligation will be void as to any product or service modified by the City to the extent such modification is the cause of the claim.

37. Survival

The Contract paragraphs titled "Patent, Copyright, Trademark, and Trade Secret Indemnification; Indemnification; and Limit of Liability" shall survive the expiration of this Contract. Software licenses, leases, maintenance and any other unexpired Agreements that were entered into under the terms and conditions of this Contract shall survive this Contract.

38. Disclosure Regarding Responsibility

A. Any prospective Contractor and any of its Principals who enter into a contract greater than sixty thousand dollars (\$60,000.00) with any City for professional services, tangible personal property, services or construction agrees to disclose whether the Contractor, or any principal of the Contractor's company is presently debarred, suspended, proposed for debarment, or declared ineligible for award of contract by any federal entity, state agency or local public body.

B. Principal, for the purpose of this disclosure, means an officer, director, owner, partner, or a person having primary management or supervisory responsibilities within a business entity or related entities.

C. The Contractor shall provide immediate written notice to the City if, at any time during the term of this Contract, the Contractor learns that the Contractor's disclosure was at any time erroneous or

became erroneous by reason of changed circumstances.

D. A disclosure that any of the items in this requirement exist will not necessarily result in termination of this Contract. However, the disclosure will be considered in the determination of the Contractor's responsibility and ability to perform under this Contract. Failure of the Contractor to furnish a disclosure or provide additional information as requested will be grounds for immediate termination of this Contract pursuant to the conditions set forth in Paragraph 7 of this Contract.

E. Nothing contained in the foregoing shall be construed to require establishment of a system of records in order to render, in good faith, the disclosure required by this document. The knowledge and information of a Contractor is not required to exceed that which is the normally possessed by a prudent person in the ordinary course of business dealings.

F. The disclosure requirement provided is a material representation of fact upon which reliance was placed when making an award and is a continuing material representation of the facts during the term of this Contract. If during the performance of the contract, the Contractor is indicted for or otherwise criminally or civilly charged by any government entity (federal, state or local) with commission of any offenses named in this document the Contractor must provide immediate written notice to the City. If it is later determined that the Contractor knowingly rendered an erroneous disclosure, in addition to other remedies available to the Government, the City may terminate the involved contract for cause. Still further the City may suspend or debar the Contractor from eligibility for future solicitations until such time as the matter is resolved to the satisfaction of the City.

39. Suspension, Delay or Interruption of Work

The City may, without cause, order the Contractor, in writing, to suspend, delay or interrupt the work in whole or in part for such period of time as the City may determine. The contract sum and contract time shall be adjusted for increases in cost and/or time associated with Contractor's compliance therewith. Upon receipt of such notice, Contractor shall leave the jobsite and any equipment in a safe condition prior to departing. Contractor must assert rights to additional compensation within thirty (30) days after suspension of work is lifted and return to work is authorized. Any compensation requested for which entitlement is granted and the contract sum adjusted, shall have profit included (for work completed) and for cost only (not profit) for Contractor costs incurred directly tied to the suspension itself and not otherwise covered by Contract remedy. Any change in Total Compensation must be reflected in an Amendment executed pursuant to Section 8 of this Contract.

40. Notification

Either party may give written notice to the other party in accordance with the terms of this Paragraph. Any written notice required or permitted to be given hereunder shall be deemed to have been given on the date of delivery if delivered by personal service or hand delivery or three (3) business days after being mailed.

To the City: Chief Procurement Officer purchasing@santafenm.gov PO Box 909 Santa Fe, NM 87504-0909	LeRoy Alvarado Wastewater Management Division 73 Paseo Real Santa Fe, NM 87507 lmalvarado@santafenm.gov	To the Contractor: Andritz Separation Inc. Robert King, Senior Vice President 1010 Commercial Blvd South Pittsburg, TX 75686 Robert.king@andritz.com
---	---	--

Either party may change its representative or address above by written notice to the other in accordance with the terms of this Paragraph. The carrier for mail delivery and notices shall be the agent of the sender.

41. Succession

This Contract shall extend to and be binding upon the successors and assigns of the parties.

IN WITNESS WHEREOF, the Parties have executed this Contract as of the date of the signature by the required approval authorities below.

City of Santa Fe:

Contractor:

Robert King (Dec 29, 2025 13:04:35 EST)

Robert King, Sr. Vice President

MAYOR

Date: _____

Date: Dec 29, 2025

NMBTIN: _____

Attest:

GERALYN CARDENAS, INTERIM CITY CLERK

Approved to form and legal sufficiency by:

Marcos Martínez
Ma rc os Martínez (Dec 29, 2025 11:05:13 M5 T)

MARCOS MARTÍNEZ, SENIOR ASSISTANT CITY ATTORNEY

Approved for Finances:

01/15/2026

BALAN MOYA

Finance Director

Exhibit A

The City of Santa Fe, New Mexico owns and operates three (3) 2-meter Andritz belt filter presses (BFP) to dewater sanitary sewage sludge prior to landfilling or composting for disposal. Two (2) of the three (3) BFPs are in need of rebuilding and rehabilitating in areas identified by Andritz technicians.

All parts and lubricants provided shall be OEM compliant and supplied by the equipment manufacturer. Aftermarket or generic parts shall not be accepted. The sourcing of all parts provided for this project shall be submitted to the Department Contact for verification and approval prior to ordering.

Owner's responsibilities:

- Owner shall be responsible for removal of walkways, grating and other interferences to provide access to the BFPs.
- No work shall be done to the frame. After disassembly of BFPs onsite, Owner shall be responsible to address any corrosion on frame, if needed, such as cold galvanizing contaminated areas.
- Owner shall be responsible for power washing and cleaning of sludge from the BFPs prior to work.
- Owner shall be responsible for disconnecting and reconnection of all utilities from the BFPs such as sludge, water, drains, compressed air and electrical services.

Contractor's responsibilities:

- Contractor shall be responsible for proper cleaning and gathering of all trash, replacement parts, used oil and grease as it pertains to the work being performed by Contractor personnel and placing it in Owners designated area or dumpster. Owner is responsible for coordinating all disposal.
- Contractor shall prepay for shipping of rolls and components to and from Andritz service center to be refurbished to OEM spec for second rebuild or for the new rollers and components needed. Shipping is to be pre-paid and added to the invoice as a separate line item to be paid for by the Department.
- Contractor to provide (2) service technicians to be onsite for fifteen (15) days, five (5) days to disassemble existing BFP, ten (10) days to reassemble and start up to check the electrical and pneumatic systems for proper operation.
- Contractor will provide forklift, as needed

The following items shall be supplied and installed during the refurbishment of each BFP:

- Depending on the condition of the rollers at time of inspection - Complete set of new rollers and bearing housings supplied for entire BFP.
- All rollers and bearing housings will be coated to OEM specifications.
- Sidewall seals
- Headbox seal
- Set of dewatering belts
- Plow chicanes
- Wear strips (gravity and wedge zone)
- Upper and lower shower seals
- Shower pipes

- Doctor blades
- Hydraulic cylinders for tension assembly
- Hydraulic cylinders for tracking assemblies
- Tracking control valve and paddles
- Garmotor
- E-stop and limit switches
- Retrofitted with hydraulic lines and fittings

Site Work for each BFP:

- BFPs will be disassembled and then reassembled onsite in Santa Fe.
- Rollers shall be inspected by factory trained technicians. Rollers found needing additional repairs (such as machining of roller journals) will be photographed, documented and approved by the Department for additional repairs provided.
- Depending on inspection - Rollers & Bearing Housing from BFPs in need of refurbishing will be stripped and re-coated according to OEM specifications.
- Drive and tracking will have new rubber coating, the s-rolls will be Rilsan coated per OEM specification. New seals and bearings will be supplied.

EXHIBIT B

Selected	Line Item	Description	Quantity	Unit of Measure	Unit Cost	Total
1		Rebuilding and rehabilitating Andritz belt filter press with hydraulic upgrade.	2	Lump Sum	\$272,202.00	\$544,404.00
2		New set of rollers with bearings and housings.	1	Lump Sum	\$165,125.00	\$165,125.00
3		Refurbish Set of Rollers with New Bearings, recoat rollers, refurbish bearing housings.	1	Lump Sum	\$45,374.00	\$45,374.00
4		Forklift	1	Daily	\$325.00	\$325.00
Total						\$755,228.00



City of Santa Fe, NM
Purchasing
 Travis Dutton-Leyda, Chief Procurement Officer
 200 Lincoln Avenue, Santa Fe, NM 87501

EVALUATION TABULATION
 ITB No. 26024
Sewage Sludge Belt Filter Press
 RESPONSE DEADLINE: October 21, 2025 at 2:00 pm
 Report Generated: Monday, December 29, 2025

SELECTED VENDOR TOTALS

Vendor	Total
Andritz Separation, Inc.	\$0.00
GSM Engineered Fabrics LLC	\$0.00

TABLE 1

Selected	Line Item	Description	Quantity	Unit of Measure	Andritz Separation, Inc.		GSM Engineered Fabrics LLC	
					Unit Cost	Total	Unit Cost	Total
	1	Rebuilding and rehabilitating Andritz belt filter press with hydraulic upgrade.	2	Lump Sum	\$272,202.00	\$544,404.00	\$87,656.50	\$175,313.00
	2	New set of rollers with bearings and housings.	1	Lump Sum	\$165,125.00	\$165,125.00	\$178,094.00	\$178,094.00
	3	Refurbish Set of Rollers with New Bearings, recoat rollers, refurbish bearing housings.	1	Lump Sum	\$45,374.00	\$45,374.00	\$90,333.00	\$90,333.00
	4	Forklift	1	Daily	\$325.00	\$325.00	\$6,500.00	\$6,500.00
Total						\$0.00		\$0.00

EVALUATION TABULATION
ITB No. 26024
Sewage Sludge Belt Filter Press

TABLE 2

			Andritz Separation, Inc.	GSM Engineered Fabrics LLC
Line Item	Description	Unit of Measure	Percentage	Percentage
5	Discount off parts needed during rebuilding and rehabilitating BFPs - If no discount, then enter "0".	Discount	10%	0%

From: [DUTTON-LEYDA, TRAVIS K.](#)
To: [MACALLISTER, LINDA M. \(Contractor\); Purchasing DET](#)
Cc: [ALVARADO, LEROY M.](#); [HEERBRANDT, PAUL F.](#)
Subject: Re: follow up// DETERMINATION REQUEST- Belt Filter Press Rehab Project
Date: Friday, September 5, 2025 12:08:26 PM
Attachments: [Outlook-CITY LOGO .png](#)
[image001.png](#)
[Outlook-yrgu24rm.png](#)
[Outlook-Chart, tex](#)

Greetings,

Based on the provided scope of work, it has been classified as General Services. This determination is solely focused on that classification and does not address whether the scope of work or procurement method complies with all relevant legal requirements. I reserve the right to modify this determination should the scope of work differ from what was originally submitted. The procurement must follow the processes and procedures established by the City of Santa Fe, Central Purchasing, the Procurement Manual, and applicable state statutes.

Please note:

- Save this email as a PDF and upload it into the corresponding packet and Munis records.
- Check with WorkQuest dba Horizons of New Mexico (vendor # 8673) (mloehman@horizonsofnewmexico.org) **if** this service appears on their approved list.
- If your request includes anything that needs to be reviewed and preapproved by another City Department/Division, please send the same SOW to the corresponding email address and include their response in your packet/Munis.

-Treasury (Point of Sale Systems) – questions: drsena@santafenm.gov; clromero@santafenm.gov. Request signature from: clromero@santafenm.gov

-IT components (everything IT) – questions: ereview@santafenm.gov. Request signature from: edcandelaria@santafenm.gov;
Copy: xzdushdurova@santafenm.gov; lenobes@santafenm.gov; lfworstell@santafenm.gov

-Vehicles – questions: fleet@santafenm.gov. Request signature from: dmjaramillo@santafenm.gov

-Grants – questions: grants@santafenm.gov. Request signature from: evlujan@santafenm.gov

- Construction, Facilities, Furniture, Fixtures, Equipment, etc. – questions: fmdreview@santafenm.gov. Request signature from: jsburnett@santafenm.gov _

-Emergency Related Purchases – questions oem@santafenm.govand. Request signature from: bgwilliams@santafenm.gov

-Asset over \$5k – questions: accountspayable@santafenm.gov. Request signature from: jxbolden@santafenm.gov

- Ensure that the appropriate templates and forms are used https://intranet.santafenm.gov/finance_1 and documented [procedures/laws/rules](#) are followed. _
- > \$20k per year, when processing this procurement, please ensure the procurement number issued by Munis and the procurement name are used in the appropriate documents and the subject of emails.
- If you are processing a procurement where the forecasted amount is => \$60k, per

NMSA 1978, Section 13-1-102, the procurement method must be ITB (if you choose not to use a cooperative or an existing contract). If you feel you need to process an RFP, you must get an Authorization and Plan approved before you process.

- < \$20k per year, one quote is acceptable.
- From \$20k to \$60k per year, if you aren't using a cooperative or existing contract, you must provide 3 quotes in your req. Must use the Munis Bid Module, OpenGov, or Pavilion.
- **Identify your funding source and notify Purchasing.**
It's essential to determine the funding source early, as it impacts the required documentation and contract language. For example, if federal funds are being used, specific federal provisions must be included in both the procurement request and the resulting contract. Notifying Purchasing of the funding source upfront ensures compliance and avoids delays.
- Follow the link below to review existing price agreements, contracts, or cooperative agreements that might be applicable to this request. You might be able to use an existing price agreement/contract to save time and money.
 - [Pavilion: Free Cooperative Contract Search for Governments](#) (please work with Purchasing if you think you found an existing or cooperative contract that might work)
- Submit via [Submit Purchase Requests](#) or the appropriate email address:
 - Determination requests to purchasing_det@santafenm.gov
 - All other requests to purchasing@santafenm.gov

Thank you for submitting this scope of work for my review.

 [Book time to meet with me](#)

Regards,

Travis Dutton-Leyda, City of Santa Fe Chief Procurement Officer

200 Lincoln Avenue

Santa Fe, NM 87501

505-629-8351

tkduttonleyda@santafenm.gov

Vendor Registration Sites and Current Procurement Opportunities:

[Current] <https://santafenm.munisselfservice.com/vss/>

[Transitioning] <https://procurement.opengov.com/portal/santafenm>

[Current] <https://www.withpavilion.com/>

Internal Link: https://intranet.santafenm.gov/central_purchasing_division_cpd



"A journey of a thousand miles begins with a single step" ~ Lao Tzu

From: MACALLISTER, LINDA M. (Contractor) <Immacallister@santafenm.gov>
Sent: Friday, September 5, 2025 11:22 AM
To: Purchasing DET <purchasing_det@santafenm.gov>
Cc: ALVARADO, LEROY M. <Imalvarado@santafenm.gov>; HEERBRANDT, PAUL F. <pfheerbrandt@santafenm.gov>
Subject: follow up// DETERMINATION REQUEST- Belt Filter Press Rehab Project

Hello Travis,

Looking for a status on the determination for (Belt Filter Press)....

Thanks,

Linda MacAllister

Contract Specialist
City of Santa Fe Waste Water/Purchasing
Cell: 505-577-6731



From: HEERBRANDT, PAUL F. <pfheerbrandt@santafenm.gov>
Sent: Friday, August 29, 2025 1:02 PM
To: Purchasing DET <purchasing_det@santafenm.gov>
Cc: MACALLISTER, LINDA M. (Contractor) <Immacallister@santafenm.gov>
Subject: Belt Filter Press Rehab Project

We'll be doing an ITB.

Thanks



P. Fred Heerbrandt, P.E.
Engineer Supervisor Wastewater
City of Santa Fe
505-955-4623

pfheerbrandt@santafenm.gov



Log # {Finance use only}	
Journal # {Finance use only}	

City of Santa Fe, New Mexico BUDGET AMENDMENT RESOLUTION (BAR)

DEPARTMENT / DIVISION NAME Public Utilities/Wastewater					DATE 8/11/2025	
ITEM DESCRIPTION	ORG	OBJECT	PROJECT	INCREASE	DECREASE	
EXPENDITURES				<i>{enter as positive #}</i>	<i>{enter as negative #}</i>	
WW CAPITAL PROJECTS/WIP CONSTRUCTION	5000375	572970		\$ 771,320		
REVENUES				<i>{enter as negative #}</i>	<i>{enter as positive #}</i>	
JUSTIFICATION: <i>(use additional page if needed)</i> <i>--Attach supporting documentation/memo</i>				\$ 771,320	\$ -	
To increase account 572970 for ANDRTIZ. Plese see memo for detail and please add ANDRTIZ for posting of BAR				<i>{Complete section below if BAR results in a net change to ANY Fund}</i>		
				Fund(s) Affected	Fund Balance Increase/(Decrease)	
				500	(771,320)	
				TOTAL: (771,320)		
Linda MacAllister	11/26/2025	<i>{Use this form for Finance Committee/ City Council agenda items ONLY}</i>		<i>Andy Hopkins</i>		01/15/2026
Prepared By <i>{print name}</i>	Date	CITY COUNCIL APPROVAL		Budget Officer		Date
		City Council		Finance Director <i>{ ≤ \$5,000}</i>		Date
Division Director Signature <i>{optional}</i>	Date	Approval Date		City Manager <i>{ ≤ \$60,000}</i>		Date
		Agenda Item #:				
Department Director Signature	Date					



CERTIFICATE OF LIABILITY INSURANCE

DATE (MM/DD/YYYY)
12/01/2025

THIS CERTIFICATE IS ISSUED AS A MATTER OF INFORMATION ONLY AND CONFERS NO RIGHTS UPON THE CERTIFICATE HOLDER. THIS CERTIFICATE DOES NOT AFFIRMATIVELY OR NEGATIVELY AMEND, EXTEND OR ALTER THE COVERAGE AFFORDED BY THE POLICIES BELOW. THIS CERTIFICATE OF INSURANCE DOES NOT CONSTITUTE A CONTRACT BETWEEN THE ISSUING INSURER(S), AUTHORIZED REPRESENTATIVE OR PRODUCER, AND THE CERTIFICATE HOLDER.

IMPORTANT: If the certificate holder is an ADDITIONAL INSURED, the policy(ies) must have ADDITIONAL INSURED provisions or be endorsed. If SUBROGATION IS WAIVED, subject to the terms and conditions of the policy, certain policies may require an endorsement. A statement on this certificate does not confer rights to the certificate holder in lieu of such endorsement(s).

PRODUCER MARSH USA, LLC. TWO ALLIANCE CENTER 3560 LENOX ROAD, SUITE 2400 ATLANTA, GA 30326 CN102376932-MAX-11/1-25-26	<table border="1" style="width: 100%; border-collapse: collapse;"> <tr> <td colspan="2">CONTACT NAME:</td> </tr> <tr> <td>PHONE (A/C, No, Ext):</td> <td>FAX (A/C, No):</td> </tr> <tr> <td colspan="2">E-MAIL ADDRESS:</td> </tr> <tr> <td colspan="2" style="text-align: center;">INSURER(S) AFFORDING COVERAGE</td> </tr> <tr> <td>INSURER A : Liberty Mutual Fire Insurance Company</td> <td>23035</td> </tr> <tr> <td>INSURER B : Liberty Insurance Corporation</td> <td>42404</td> </tr> <tr> <td>INSURER C :</td> <td></td> </tr> <tr> <td>INSURER D :</td> <td></td> </tr> <tr> <td>INSURER E :</td> <td></td> </tr> <tr> <td>INSURER F :</td> <td></td> </tr> </table>	CONTACT NAME:		PHONE (A/C, No, Ext):	FAX (A/C, No):	E-MAIL ADDRESS:		INSURER(S) AFFORDING COVERAGE		INSURER A : Liberty Mutual Fire Insurance Company	23035	INSURER B : Liberty Insurance Corporation	42404	INSURER C :		INSURER D :		INSURER E :		INSURER F :	
CONTACT NAME:																					
PHONE (A/C, No, Ext):	FAX (A/C, No):																				
E-MAIL ADDRESS:																					
INSURER(S) AFFORDING COVERAGE																					
INSURER A : Liberty Mutual Fire Insurance Company	23035																				
INSURER B : Liberty Insurance Corporation	42404																				
INSURER C :																					
INSURER D :																					
INSURER E :																					
INSURER F :																					

COVERAGES **CERTIFICATE NUMBER:** ATL-005750439-08 **REVISION NUMBER:** 0

THIS IS TO CERTIFY THAT THE POLICIES OF INSURANCE LISTED BELOW HAVE BEEN ISSUED TO THE INSURED NAMED ABOVE FOR THE POLICY PERIOD INDICATED. NOTWITHSTANDING ANY REQUIREMENT, TERM OR CONDITION OF ANY CONTRACT OR OTHER DOCUMENT WITH RESPECT TO WHICH THIS CERTIFICATE MAY BE ISSUED OR MAY PERTAIN, THE INSURANCE AFFORDED BY THE POLICIES DESCRIBED HEREIN IS SUBJECT TO ALL THE TERMS, EXCLUSIONS AND CONDITIONS OF SUCH POLICIES. LIMITS SHOWN MAY HAVE BEEN REDUCED BY PAID CLAIMS.

INSR LTR	TYPE OF INSURANCE	ADDL INSD	SUBR WVD	POLICY NUMBER	POLICY EFF (MM/DD/YYYY)	POLICY EXP (MM/DD/YYYY)	LIMITS																				
A	<input checked="" type="checkbox"/> COMMERCIAL GENERAL LIABILITY <table border="1" style="width: 100%; border-collapse: collapse;"> <tr> <td style="width: 50%;">CLAIMS-MADE</td> <td style="width: 50%; text-align: center;"><input checked="" type="checkbox"/> OCCUR</td> </tr> <tr> <td colspan="2"> GEN'L AGGREGATE LIMIT APPLIES PER: <input checked="" type="checkbox"/> POLICY <input type="checkbox"/> JECT <input type="checkbox"/> LOC </td> </tr> <tr> <td colspan="2">OTHER:</td> </tr> </table>	CLAIMS-MADE	<input checked="" type="checkbox"/> OCCUR	GEN'L AGGREGATE LIMIT APPLIES PER: <input checked="" type="checkbox"/> POLICY <input type="checkbox"/> JECT <input type="checkbox"/> LOC		OTHER:				TB2-651-004304-105	11/01/2025	11/01/2026	<table border="1" style="width: 100%; border-collapse: collapse;"> <tr><td>EACH OCCURRENCE</td><td style="text-align: right;">\$ 10,000,000</td></tr> <tr><td>DAMAGE TO RENTED PREMISES (Ea occurrence)</td><td style="text-align: right;">\$ 10,000,000</td></tr> <tr><td>MED EXP (Any one person)</td><td style="text-align: right;">\$ 5,000</td></tr> <tr><td>PERSONAL & ADV INJURY</td><td style="text-align: right;">\$ 10,000,000</td></tr> <tr><td>GENERAL AGGREGATE</td><td style="text-align: right;">\$ 10,000,000</td></tr> <tr><td>PRODUCTS - COMP/OP AGG</td><td style="text-align: right;">\$ 10,000,000</td></tr> <tr><td> </td><td style="text-align: right;">\$</td></tr> </table>	EACH OCCURRENCE	\$ 10,000,000	DAMAGE TO RENTED PREMISES (Ea occurrence)	\$ 10,000,000	MED EXP (Any one person)	\$ 5,000	PERSONAL & ADV INJURY	\$ 10,000,000	GENERAL AGGREGATE	\$ 10,000,000	PRODUCTS - COMP/OP AGG	\$ 10,000,000		\$
CLAIMS-MADE	<input checked="" type="checkbox"/> OCCUR																										
GEN'L AGGREGATE LIMIT APPLIES PER: <input checked="" type="checkbox"/> POLICY <input type="checkbox"/> JECT <input type="checkbox"/> LOC																											
OTHER:																											
EACH OCCURRENCE	\$ 10,000,000																										
DAMAGE TO RENTED PREMISES (Ea occurrence)	\$ 10,000,000																										
MED EXP (Any one person)	\$ 5,000																										
PERSONAL & ADV INJURY	\$ 10,000,000																										
GENERAL AGGREGATE	\$ 10,000,000																										
PRODUCTS - COMP/OP AGG	\$ 10,000,000																										
	\$																										
A	AUTOMOBILE LIABILITY <input checked="" type="checkbox"/> ANY AUTO <table border="1" style="width: 100%; border-collapse: collapse;"> <tr> <td style="width: 50%;">OWNED AUTOS ONLY</td> <td style="width: 50%;">SCHEDULED AUTOS</td> </tr> <tr> <td>HIRED AUTOS ONLY</td> <td>NON-OWNED AUTOS ONLY</td> </tr> </table>	OWNED AUTOS ONLY	SCHEDULED AUTOS	HIRED AUTOS ONLY	NON-OWNED AUTOS ONLY			AS2-651-004304-035	11/01/2025	11/01/2026	<table border="1" style="width: 100%; border-collapse: collapse;"> <tr><td>COMBINED SINGLE LIMIT (Ea accident)</td><td style="text-align: right;">\$ 2,000,000</td></tr> <tr><td>BODILY INJURY (Per person)</td><td style="text-align: right;">\$</td></tr> <tr><td>BODILY INJURY (Per accident)</td><td style="text-align: right;">\$</td></tr> <tr><td>PROPERTY DAMAGE (Per accident)</td><td style="text-align: right;">\$</td></tr> <tr><td> </td><td style="text-align: right;">\$</td></tr> </table>	COMBINED SINGLE LIMIT (Ea accident)	\$ 2,000,000	BODILY INJURY (Per person)	\$	BODILY INJURY (Per accident)	\$	PROPERTY DAMAGE (Per accident)	\$		\$						
OWNED AUTOS ONLY	SCHEDULED AUTOS																										
HIRED AUTOS ONLY	NON-OWNED AUTOS ONLY																										
COMBINED SINGLE LIMIT (Ea accident)	\$ 2,000,000																										
BODILY INJURY (Per person)	\$																										
BODILY INJURY (Per accident)	\$																										
PROPERTY DAMAGE (Per accident)	\$																										
	\$																										
	UMBRELLA LIAB <input type="checkbox"/> OCCUR EXCESS LIAB <input type="checkbox"/> CLAIMS-MADE DED RETENTION \$						<table border="1" style="width: 100%; border-collapse: collapse;"> <tr><td>EACH OCCURRENCE</td><td style="text-align: right;">\$</td></tr> <tr><td>AGGREGATE</td><td style="text-align: right;">\$</td></tr> <tr><td> </td><td style="text-align: right;">\$</td></tr> </table>	EACH OCCURRENCE	\$	AGGREGATE	\$		\$														
EACH OCCURRENCE	\$																										
AGGREGATE	\$																										
	\$																										
B	WORKERS COMPENSATION AND EMPLOYERS' LIABILITY Y / N ANY PROPRIETOR/PARTNER/EXECUTIVE OFFICER/MEMBER EXCLUDED? <input type="checkbox"/> N <input type="checkbox"/> N/A (Mandatory in NH) If yes, describe under DESCRIPTION OF OPERATIONS below			WA5-65D-004304-135 (AOS) WC5-651-004304-145 (WI)	11/01/2025 11/01/2025	11/01/2026 11/01/2026	<table border="1" style="width: 100%; border-collapse: collapse;"> <tr> <td style="width: 50%;"> <input checked="" type="checkbox"/> PER STATUTE <input type="checkbox"/> OTHER </td> <td style="width: 50%;"></td> </tr> <tr><td>E.L. EACH ACCIDENT</td><td style="text-align: right;">\$ 1,000,000</td></tr> <tr><td>E.L. DISEASE - EA EMPLOYEE</td><td style="text-align: right;">\$ 1,000,000</td></tr> <tr><td>E.L. DISEASE - POLICY LIMIT</td><td style="text-align: right;">\$ 1,000,000</td></tr> </table>	<input checked="" type="checkbox"/> PER STATUTE <input type="checkbox"/> OTHER		E.L. EACH ACCIDENT	\$ 1,000,000	E.L. DISEASE - EA EMPLOYEE	\$ 1,000,000	E.L. DISEASE - POLICY LIMIT	\$ 1,000,000												
<input checked="" type="checkbox"/> PER STATUTE <input type="checkbox"/> OTHER																											
E.L. EACH ACCIDENT	\$ 1,000,000																										
E.L. DISEASE - EA EMPLOYEE	\$ 1,000,000																										
E.L. DISEASE - POLICY LIMIT	\$ 1,000,000																										

DESCRIPTION OF OPERATIONS / LOCATIONS / VEHICLES (ACORD 101, Additional Remarks Schedule, may be attached if more space is required)
 RE: Project 807217, City of Santa Fe. City of Santa Fe is added as an Additional Insured with respect to the General Liability and Automobile Liability policies, if required by written contract with Certificate Holder and subject to the policy terms, conditions and exclusions.

CERTIFICATE HOLDER City of Santa Fe 200 Lincoln Avenue Santa Fe, NM 87504	CANCELLATION SHOULD ANY OF THE ABOVE DESCRIBED POLICIES BE CANCELLED BEFORE THE EXPIRATION DATE THEREOF, NOTICE WILL BE DELIVERED IN ACCORDANCE WITH THE POLICY PROVISIONS. AUTHORIZED REPRESENTATIVE <p style="text-align: right;"><i>Marsh USA LLC</i></p>
---	--

© 1988-2016 ACORD CORPORATION. All rights reserved.

From: [DUTTON-LEYDA, TRAVIS K.](#)
To: [SANCHEZ, KATHY S.](#)
Cc: [PEREZ, ALYSSA E. \(Contractor\)](#); [MACALLISTER, LINDA M. \(Contractor\)](#)
Subject: RE: Comment Added by Travis Dutton-Leyda (2026-495-Request)
Date: Tuesday, January 13, 2026 5:21:21 PM
Attachments: [image003.png](#)
[image005.png](#)
[image006.png](#)

Kathy,

Based on my review of the ITB, bidder correspondence, and the facts presented, this serves as my official determination.

The ITB explicitly required OEM parts and manufacturer-trained and certified personnel. These requirements were clearly stated in the specifications. The apparent low bidder did not object to, protest, or challenge these requirements during the solicitation process. While the bidder submitted questions, those questions were addressed, and the OEM requirements were reaffirmed prior to bid submission.

Despite this, the bidder elected to submit a bid that did not comply with the OEM requirements and subsequently took exceptions to the specifications after bid opening. Taking exceptions at the time of award renders the bid non-responsive and cannot be cured after opening.

While it is always appropriate for departments to thoroughly evaluate available alternatives during the specification-development phase, including determining whether “equal or better” products or services may be acceptable, those determinations must be made and reflected in the solicitation prior to issuance. In this case, the ITB was written as a brand-name requirement with no approved equals.

Accordingly, non-OEM or aftermarket parts cannot be considered at the award stage. Based on the information provided, rejection of the apparent low bid as non-responsive and proceeding with award to the responsive bidder is appropriate and consistent with procurement requirements.

Regarding the contract term, I concur with Marcos that a two-year contract term is permissible.

Thank you.

Regards,

Travis Dutton-Leyda
Chief Procurement Officer
City of Santa Fe
200 Lincoln Avenue
Santa Fe, NM 87501
505-629-8351
tkduttonleyda@santafenm.gov



[Book time to meet with me](#)

<https://santafenm.gov/finance-2/purchasing-1>

Vendor Registration Sites and Current Procurement Opportunities:

[Current for Finances Only] <https://santafenm.munisselfservice.com/vss/>

[We Are Live With OpenGov] <https://procurement.opengov.com/portal/santafenm>

[Current] <https://www.withpavilion.com/>

Internal Link: https://intranet.santafenm.gov/central_purchasing_division_cpd



CITY OF SANTA FE
FINANCE

“A journey of a thousand miles begins with a single step” ~ Lao Tzu

From: SANCHEZ, KATHY S. <kssanchez@santafenm.gov>

Sent: Monday, January 12, 2026 1:12 PM

To: DUTTON-LEYDA, TRAVIS K. <tkduttonleyda@santafenm.gov>; MACALLISTER, LINDA M. (Contractor) <Immacallister@santafenm.gov>

Cc: PEREZ, ALYSSA E. (Contractor) <aeperez@santafenm.gov>

Subject: RE: Comment Added by Travis Dutton-Leyda (2026-495-Request)

Travis, just bringing this up to the top of your list.

Kathy

From: SANCHEZ, KATHY S.

Sent: Thursday, January 8, 2026 5:03 PM

To: DUTTON-LEYDA, TRAVIS K. <tkduttonleyda@santafenm.gov>; MACALLISTER, LINDA M. (Contractor) <Immacallister@santafenm.gov>

Cc: PEREZ, ALYSSA E. (Contractor) <aeperez@santafenm.gov>

Subject: RE: Comment Added by Travis Dutton-Leyda (2026-495-Request)

Travis, the Department made the decision to not allow aftermarket or generic parts when drawing up the specifications for this critical piece of equipment that the Department cannot afford to have break down. The specifications required OEM parts and personnel trained by the manufacturer to repair the equipment.

The low bidder asked this question: We noticed in the intent to BID that Andritz technicians have been on site to inspect the equipment. This is a basic rebuild since the frame is not being removed. GSM is currently rebuilding several customer belt presses that are the same generation / model as the ones Santa-Fe has in operation. Is there a way to get the

scope of work more defined, was there any discussions about going back with upgraded components instead of the original outdated items which will give better performance and life expectancy?

I responded with: The scope of work discusses refabricating parts and providing new parts for the equipment rebuild. You may use all new parts, if you choose to accomplish the rebuild in this manner. All parts must be OEM, as also stated in the scope.

The low bidder did not protest the specifications nor say the specifications restricted the bid. Instead, they bid 3rd party parts instead of OEM parts. When Fred was going to award to this vendor, he sent the following email for verification:

On Mon, Nov 3, 2025 at 1:32 PM HEERBRANDT, PAUL F.

<pfheerbrandt@santafenm.gov> wrote:

Good Morning, Mr. Helin,

Your company, GSM Engineered Fabrics, LLC, is the apparent low bidder for this procurement.

We are contacting you to determine if your bid is compliant with the specifications contained in the ITB documents. The specs state:

Technicians performing the assembly and disassembly of the presses shall be factory trained by Andritz on the maintenance of the 2-meter Andritz CPF 2.0M SMX-S8 Belt Filter Press model. Technicians shall also be certified by the manufacturer for warranty work on these units.

-

The specs also states:

-

All parts and lubricants provided shall be OEM compliant and supplied by the equipment manufacturer. Aftermarket or generic parts shall not be accepted. Invoices showing the source of all parts provided for this project shall be submitted to the Procurement Manager for verification.

-

Please provide a Certification Statement, or invoices, from the company owner or manager stating that your bid complies with these two sections of the specifications. If the purchasing department determines that the bid is compliant with the specifications, a contract will be forwarded to you for execution. Please provide the name and email of the person responsible for executing the contract, so that it can be forwarded directly to them for review and signature.

Thank you for participating in this procurement.

Fred

The low bidder responded with the attached letter. The bid had already been opened and then, at time of award, they take exceptions to the bid specifications. Based on all the above, the low bidder did not submit a responsive bid, and I instructed the Department to proceed with

the award to the only other bidder.

Is this enough information to get a determination to “reject” the low bid?

I am also going to send an email to Legal about issuing a two-year contract instead of a one-year contract. I will keep you informed about the term.

Kathy

From: DUTTON-LEYDA, TRAVIS K. <tkduttonleyda@santafenm.gov>
Sent: Thursday, January 8, 2026 2:14 PM
To: MACALLISTER, LINDA M. (Contractor) <lmmacallister@santafenm.gov>
Cc: PEREZ, ALYSSA E. (Contractor) <aeperez@santafenm.gov>; SANCHEZ, KATHY S. <kssanchez@santafenm.gov>
Subject: RE: Comment Added by Travis Dutton-Leyda (2026-495-Request)

Linda

That needs to be documented in the file as a CPO award determination. Here are the supporting statute and rule:

13-1-108. Competitive sealed bids; award.

A contract solicited by competitive sealed bids shall be awarded with reasonable promptness by written **notice to the lowest responsible bidder**. Contracts solicited by competitive sealed bids shall require that the bid amount exclude the applicable state gross receipts tax or applicable local option tax but that the contracting agency shall be required to pay the applicable tax including any increase in the applicable tax becoming effective after the date the contract is entered into. The applicable gross receipts tax or applicable local option tax shall be shown as a separate amount on each billing or request for payment made under the contract.

And

1.4.1.71 REJECTION OF INDIVIDUAL *BIDS* OR PROPOSALS:

A. Reasons for rejection:

(1) Bids. As used in this section, "bid" means competitive sealed bids. Reasons for rejecting a bid shall include but are not limited to:

(a) the business that submitted the bid is nonresponsible as determined under [1.4.1.73](#) NMAC of this rule;

(b) the bid is not responsive; or

(c) the service, construction, or item of tangible personal property offered in the bid is unacceptable by reason of its failure to meet the requirements of the specifications, or permissible alternates, or other acceptability criteria set forth in the IFB.

(2) Proposals. As used in this section, "proposal" means competitive sealed proposals. Unless the solicitation states otherwise, proposals need not be unconditionally accepted without alteration or correction and a using agency's stated requirements may be revised or clarified after proposals are submitted. This flexibility must be considered in determining whether

reasons exist for rejecting all or any part of a proposal. Reasons for rejecting proposals include but are not limited to:

- (a) the business that submitted the proposal is nonresponsible as determined under [1.4.1.75](#) through [1.4.1.79](#) NMAC of this rule;
- (b) the proposal is not responsive; or
- (c) the proposed price is clearly unreasonable; or
- (d) the proposal failed to adequately address one or more material mandatory requirements as set forth in the request for proposals.

B. Written determination required: A written determination which contains the reasons for the rejection of an individual bid or proposal shall be prepared by the state purchasing agent or central purchasing office and made a part of the procurement file.

Thanks,
Travis

From: MACALLISTER, LINDA M. (Contractor) <lmacallister@santafenm.gov>
Sent: Thursday, January 8, 2026 1:45 PM
To: DUTTON-LEYDA, TRAVIS K. <tkduttonleyda@santafenm.gov>
Subject: RE: Comment Added by Travis Dutton-Leyda (2026-495-Request)

Linda MacAllister

1/8/26 at 1:43pm

Travis, This was a sole source originally and now an ITB per your request and the reason we picked Andritz is because they meet the OEM compliant criteria. Basically, the ITB asked for manufacturing parts and only Andritz has that criteria...

Put On Hold

Travis Dutton-Leyda on 1/8/26 at 1:22pm

Thank you.

Linda MacAllister

Contract Specialist
City of Santa Fe Waste Water/Purchasing
Cell: 505-577-6731



From: OpenGov Procurement Notifications <procurement-notifications@opengov.com>

Sent: Thursday, January 8, 2026 1:10 PM

To: MACALLISTER, LINDA M. (Contractor) <Immacallister@santafenm.gov>

Subject: Comment Added by Travis Dutton-Leyda (2026-495-Request)

CAUTION: This email originated from outside of the organization. Do not click links or open attachments unless you recognize the sender and know the content is safe.

OpenGov Procurement Logo



Hi Linda,

Travis Dutton-Leyda left the following comment on Request [2026-495-Request](#):

@Linda, why are you awarding the higher of the 2 vendors?

[View Request](#)

Questions? We're happy to help! Please do NOT respond to this email and instead reach us
at procurement-support@opengov.com.









Urgent-GB-550-Andritz

Final Audit Report

2026-01-15

Created:	2026-01-15
By:	ALYSSA PEREZ (aeperez@santafenm.gov)
Status:	Canceled / Declined
Transaction ID:	CBJCHBCAABAA2uD4vwCZ826lJg3JaGXpjM6RDe1f2ACZ

"Urgent-GB-550-Andritz" History

-  Document created by ALYSSA PEREZ (aeperez@santafenm.gov)
2026-01-15 - 3:08:47 PM GMT- IP address: 63.232.20.2
-  Document emailed to ajhopkins@santafenm.gov ajhopkins@santafenm.gov (ajhopkins@santafenm.gov) for signature
2026-01-15-3:11:07 PM GMT
-  Email viewed by ajhopkins@santafenm.gov ajhopkins@santafenm.gov (ajhopkins@santafenm.gov)
2026-01-15 - 4:38:22 PM GMT- IP address: 104.47.65.254
-  Document e-signed by ajhopkins@santafenm.gov ajhopkins@santafenm.gov (ajhopkins@santafenm.gov)
Signature Date: 2026-01-15 - 4:38:56 PM GMT - Time Source: server- IP address: 63.232.20.2
-  Document sent to JoAnn Lovato Udlovato@santafenm.gov) and Travis Dutton-Leyda (tkduttonleyda@santafenm.gov) for signature. One of them to sign
2026-01-15 - 4:38:58 PM GMT
-  Email viewed by Travis Dutton-Leyda (tkduttonleyda@santafenm.gov)
2026-01-15 - 4:57:26 PM GMT- IP address: 98.97.114.54
-  Email viewed by JoAnn Lovato Udlovato@santafenm.gov)
2026-01-15 - 7:39:58 PM GMT- IP address: 63.232.20.2
-  Document declined by JoAnn Lovato Udlovato@santafenm.gov)
Decline reason: Missing Horizons declination.
2026-01-15 - 7:44:19 PM GMT- IP address: 63.232.20.2



Services Offered to the City of Santa Fe (FY26)

Approved:

These services have been approved by the New Mexico Council for Purchasing from Persons with Disabilities and are available through Horizons of New Mexico.

- ADA Accessibility Consulting Services
- Auctioneering Services
- Bulk Mailing and Sorting
- Call Center Services
- Computer Refurbishing
- Courier Services
- Decontamination, Sanitation and Sterilization Services
- Debris Removal
- Document Imaging
- Document Shredding
- Envelope Stuffing
- General Labor
- Hard Drive Destruction
- Janitorial and Housekeeping Services – Including Carpet Cleaning & Floor Care
- Landscape Irrigation
- Landscaping
- Mailing Services
- Management of an Assistive Technology Reuse and Recycling Program
- Medical Waste Disposal
- Meeting Minute Preparation Services
- Pest Control and Extermination Services
- Printing Services
- Rest Area Maintenance
- Screen Printing
- Snow Removal
- Temporary Staffing Services
- Yard, Grounds, and Lawn Maintenance

Permissive:

The services have been approved by the New Mexico Council for Purchasing from Persons with Disabilities as permissible for sale under the State Use Act through Horizons of New Mexico. While the Council recognizes that certain Horizons of New Mexico members are capable of performing the services listed below, said services are considered permissive and excluded from the mandatory aspect of the State Use Program. Any procurement of the below services through Horizons of New Mexico is at the discretion of the purchasing agent and will be considered by the Council on a case-by-case basis.



- Graphic Design
- Graphic Design - Logo Design
- IT – Enterprise Application
- IT – IV & V
- IT Network and Database Management
- IT Support
- IT Security Services
- IT – Web Design
- IT – Web Programmer
- Marketing
- Social Media Marketing

For the complete State Use service list, please go to: <http://horizonsofnewmexico.org/services.html>

Date: January 16, 2026

To: Governing Body

From: Scott Overlie, Public Works Project Manager III 
SAO (Jan 23, 2026 14:55:21 MST)

Via: Sam Burnett, Interim Public Works Department Director 
Carol Swenson, Public Works Business Operations Manager 

Subject: Capital Appropriation Agreement Project 25-J5984, Shelby Street Pedestrian Bridge

ACTION:

Request for Approval of Capital Outlay Grant Agreement with New Mexico Department of Finance and Administration for Project Completion of the Shelby Street Pedestrian Bridge Including Demolition and New Construction, Project 25-J5984 in the Total Amount of \$260,000 With a Reversion Date of April 11, 2027. (Scott Overlie, Public Works Project Manager III, saoverlie@santafenm.gov)

1. Request for Approval of a Budget Amendment Resolution (BAR) to Allocate \$260,000 from the 2025 Capital Appropriation to FY26 Revenue and WIP Construction for the Project Completion of the Shelby Street Pedestrian Bridge Including Demolition and New Construction.

BACKGROUND AND SUMMARY:

The City of Santa Fe has been awarded Capital Outlay Project 25-J5984 in the amount of \$260,000 "...for project completion of the Shelby Street Pedestrian Bridge including demolition and new construction."

ATTACHMENTS:

Grant Agreement
PLID Form
BAR

**NEW MEXICO CAPITAL OUTLAY GRANT AGREEMENT
CAPITAL APPROPRIATION PROJECT**

THIS AGREEMENT is made and entered into by and between the State of New Mexico, Department of Finance & Administration, 407 Galisteo Street, Santa Fe, NM 87501, ("**Department**") and the City of Santa Fe, ("**Grantee**") (individually "**Party**" and collectively "**Parties**"). This Agreement shall be effective as of the date the Department executes it ("**Effective Date**").

WITNESSETH

WHEREAS, in the Laws of 2025, Chapter 159, Section 54, the Legislature made an appropriation to the Department, funds from which the Department is making available to the Grantee pursuant to this Agreement; and

WHEREAS, the Department is granting to Grantee, and the Grantee is accepting the grant of funds from this appropriation, in accordance with the terms and conditions of this Agreement;

NOW, THEREFORE, in consideration of the mutual covenants and obligations contained herein, the parties hereby mutually agree as follows:

AGREEMENT

I. PROJECT DESCRIPTION, GRANT AMOUNT, AND REVERSION

25-J5984 ("**Project**") 4/11/2027 ("**Reversion Date**"). Laws of 2025, Chapter 159, Section 54, Two Hundred Sixty Thousand Dollars and Zero Cents, \$260,000.00, For project completion of the Shelby Street Pedestrian Bridge including demolition and new construction, in Santa Fe in Santa Fe county.

Grantee's total reimbursements shall not exceed \$260,000.00 Two Hundred Sixty Thousand Dollars and Zero Cents, ("**Appropriation Amount**") minus the allocation for Art in Public Places ("**AIPP amount**"), if applicable, \$0.00 Zero Dollars, which equals \$260,000.00 Two Hundred Sixty Thousand Dollars and Zero Cents ("**Adjusted Appropriation Amount**").

In the event of a conflict among the Appropriation Amount, the Reversion Date, as defined herein and/or the purpose of the Project, as set forth in this Agreement, and the corresponding appropriation language in the laws cited above in this Article I, the language of the laws cited herein shall control.

The information contained in Article I is referred to collectively as the "**Project Description**."

II. DISBURSEMENT LIMITATION

- A. Upon the Effective Date, the Grantee shall submit to the Department a comprehensive procurement plan and expenditure plan, detailing a Project timeline with milestones, required procurements, and identifying expected expenditures per milestone (collectively, "**Project Budget**"). The Department shall review and approve the Project Budget by issuing a Notice of Department's Obligation ("**Notice of Obligation**"), in accordance with the Project Description, a sample of which is attached hereto as **Exhibit A** and incorporated herein by reference. After receipt of a Notice of Obligation, the Grantee may be reimbursed for allowable costs up to the Adjusted Appropriation Amount. This Agreement and any reimbursements up to the Adjusted Appropriation Amount are expressly conditioned upon the following:
- a. Irrespective of any Notice of Obligation, Grantee's expenditures shall be made in accordance with the Project Budget, on or before the Reversion Date and/or, if applicable, any Early Termination Date; and
 - b. The total amount received by Grantee shall not exceed the lesser of:
 - i. the Adjusted Appropriation Amount identified in Article I (B) herein; or
 - ii. the total of all amounts stated in the Notice(s) of Obligation evidencing the Department has received and accepted Grantee's Third Party Obligation(s); and
 - c. Grantee's expenditures are made and accounted for pursuant to the State Procurement Code, State's Model Accounting Practices, and execution of binding written obligations or purchase orders with third-party contractors or vendors for the provision of services, including professional services, or the purchase of tangible personal property and real property for the Project ("**Third Party Obligations**"); and
 - d. Grantee's submittal of timely Requests for Payment and supporting documentation in accordance with the procedures set forth in this Agreement; and
 - e. In the event capital assets acquired with Project funds are to be sold, leased, or licensed to or operated by a private entity, the sale, lease, license, or operating agreement:
 - i. must be approved by the applicable oversight entity (if any) in accordance with §§ 13-6-2, 13-6-2.1, and 13-6-3; or
 - ii. If no oversight entity is required to approve the transaction, the Department of Finance and Administration's Infrastructure Planning Development Division (IPDD) must approve it as complying with the law.
- B. Prior to the sale, lease, license, or operating agreement being approved pursuant to Articles II(A)(e) (i) or (ii) herein, the Department may, in its sole and absolute discretion, unless inconsistent with State Board of Finance imposed conditions, reimburse Grantee for necessary expenditures incurred to develop the Project sufficiently to make the sale,

lease, license, or operating agreement commercially feasible, limited to planning and design expenditures; and

- C. Grantee's submission of documentation of all Third Party Obligations and amendments thereto (including terminations) to the Department and the Department's issuance of a Notice of Obligation for a particular amount in accordance with the terms of this Agreement shall be governed by the following:
- a. Grantee is authorized to budget the particular amount set forth in the Notice of Obligation, execute the Third Party Obligation, and request the Third Party to begin work after issuance of a Notice of Obligation by the Department.
 - b. Grantee acknowledges and agrees that any Third Party Obligations agreed to prior to receiving a Notice of Obligation are its sole responsibility.
 - c. Grantee shall submit to the Department one copy of all Third Party Obligations and amendments thereto (including terminations) as soon as possible after execution by the Third Party but prior to execution by the Grantee.
 - d. Department may, in its sole and absolute discretion, issue a Notice of Obligation for the particular amount of a Third Party Obligation that only obligates the Department to reimburse Grantee's expenditures made on or before the Reversion Date or an Early Termination Date. The current Notice of Obligation form is incorporated herein and attached hereto as Exhibit 2.
- D. Grantee shall provide all necessary qualified personnel, materials, and facilities to implement the Project. The Grantee shall finance its share (if any) of the costs of the Project, including all Project overruns.
- E. Prior to entering into this Agreement, the Department conducted a risk assessment on the Grantee and a project readiness review for the Project. In accordance with State Model Accounting Practices, FIN 9.2, if the Department determines that the expenditure of Project funds by the Grantee requires special conditions, those conditions are identified and listed in **Exhibit D**, which is attached and incorporated by reference. The Parties agree that, to the extent the Department, in its sole and absolute discretion, determines additional special conditions are necessary or that existing special conditions are no longer required, it may update **Exhibit D** from time to time without the need for a formal amendment of this Agreement.
- F. Project funds shall not be used for purposes other than those authorized by the Department in accordance with the Project Description.
- G. Project funds cannot be used to reimburse the Grantee for indirect Project costs unless specifically allowed by law.

III. NOTICES

The following provisions shall apply whenever written notices, including written decisions, are to be given or received related to this Agreement.

The Grantee designates the person(s) listed below, or their successor, as their official representative(s) concerning all matters related to this Agreement:

Grantee: City of Santa Fe
Name: David Chapman
Title: Grant Administrator
Address: PO Box 909, Santa Fe NM, 87504
Email: dachapman@santafenm.gov
Telephone: 505-955-6251

The Grantee designates the person(s) listed below, or their successor, as their Fiscal Officer or Fiscal Agent concerning all matters related to this Agreement:

Grantee: City of Santa Fe
Name: Erika Lujan
Title: Grant Manager
Address: PO Box 909, Santa Fe NM, 87504
Email: evlujan@santafenm.gov
Telephone: 505-479-1334

The Department designates the persons listed below, or their successors, as the Points of Contact for matters related to this Agreement.

Department: DFA/Local Government Division
Name: Daniel Catanach
Title: Grant Manager
Address: Bataan Memorial Bldg. Rm 202, Santa Fe NM 87501
Email: DanielN.Catanach@dfa.nm.gov
Telephone: 505-231-6090

IV. TERM & DEADLINE TO EXPEND FUNDS

- A. The term of this Agreement shall begin on the Effective Date and terminate on the 11th day of April during the calendar year of the Reversion Date unless Terminated Before Reversion Date ("**Early Termination**") pursuant to Article V herein (collectively "**Term**").
- B. The Project's funds must be expended on or before the Reversion Date and, if applicable, the Early Termination Date of this Agreement.
 - a. For purposes of this Agreement, it is not sufficient for the Grantee to encumber the Project funds on its books on or before the Reversion Date or Early Termination Date.
 - b. For purposes of this Agreement, an expenditure of funds has occurred on the date the particular quantity of goods is delivered to and received by the Grantee,

title to the goods is transferred to the Grantee, and/or as of the date particular services are rendered to and accepted by the Grantee.

- c. For purposes of this Agreement, an encumbrance of funds pursuant to a contract or purchase order with a third party does not qualify as an expenditure.

V. EARLY TERMINATION

A. **General Provision.** The Department may terminate this Agreement before the Reversion Date based on the Completion of the Project, Complete Expenditure of the Adjusted Appropriation, and/or Violation of this Agreement. Early Termination hereunder includes:

- a. Termination due to completion of the Project before the Reversion Date;
- b. Termination due to complete expenditure of the Adjusted Appropriation Amount before the Reversion Date;
- c. Termination for violation of the terms of this Agreement; or
- d. Termination for suspected mishandling of public funds, including but not limited to fraud, waste, abuse, and conflicts of interest.

B. **Non-appropriation.** This Agreement is expressly contingent upon the New Mexico State Legislature making sufficient appropriations and authorizations for the Project Description.

- a. If the Legislature does not appropriate the Appropriation Amount, this Agreement shall terminate upon the Department giving the Grantee written notice of such termination. Such termination shall be effective as of the effective date of the law making the non-appropriation.
 - i. The Department's decision as to whether sufficient appropriations or authorizations are available shall be final. Grantee hereby waives any rights to assert an impairment of contract claim against the State of New Mexico in the event of Early Termination of this Agreement.
- b. As used herein, "non-appropriate" or "non-appropriation" includes the following actions by the New Mexico Legislature:
 - i. Deauthorization, reauthorization, or revocation of a prior authorization.

C. **Grant Disbursements in the Event of Early Termination.** In the event of Early Termination, the Department's sole and absolute obligation to reimburse the Grantee is expressly conditioned upon the limitations set forth in Article II above.

D. **Notice.** Either Party may terminate this Agreement prior to the Reversion Date by providing the other Party with a minimum of fifteen (15) days advance written notice of the Early Termination. Grantee hereby waives any rights to assert an impairment of contract claim against the State of New Mexico in the event of Early Termination of this Agreement by the Department.

VI. SUSPENSION OF NEW OR FURTHER OBLIGATIONS

- A. Department, in its sole and absolute discretion, may provide written notice to Grantee to suspend entering into further obligations. Upon the receipt of such written notice by the Grantee:
- a. Grantee shall immediately suspend entering into new or further written obligations with third parties;
 - b. Department will suspend the issuance of any new or further Notice of Obligation under this Agreement; and
 - c. Department may direct the Grantee to implement a corrective action plan in accordance with Article VI (D) herein.
- B. In the event of Suspension of this Agreement, the Department's sole and absolute obligation to reimburse the Grantee is expressly conditioned upon the limitations set forth in Article II herein.
- C. A suspension of new or further obligations under this Agreement shall remain in effect unless or until the date the Grantee receives written notice given by the Department informing the Grantee that the Suspension has been lifted or that the Agreement has been Early Terminated in accordance with Article V herein. If the Suspension is lifted, the Department will consider further requests for a Notice of Obligation.
- D. Corrective Action Plan in the Event of Suspension. Where the Department, in its sole and absolute discretion, directs Grantee to suspend entering into new or further written obligations with third parties pursuant to Article VI(A), the Department may, but is not obligated to, require the Grantee to develop and implement a written corrective action plan to remedy the grounds for the Suspension.
- a. Such a corrective action plan must be approved by the Department and be signed by the Grantee.
 - b. Failure to sign a corrective action plan or meet the terms and deadlines set forth in the signed corrective action plan is hereby deemed a violation of the terms of this Agreement for purposes of Early Termination, Article V(A)(c).
 - c. A corrective action plan shall be in addition to, and not in lieu of, any other equitable or legal remedy authorized hereunder or at law, including but not limited to Early Termination.

VII. AMENDMENTS

Unless expressly stated otherwise herein, this Agreement shall not be altered, changed, or amended except by an instrument in writing duly executed by both parties hereto with the same formalities as this agreement.

VIII. REPORTING

A. Database Reporting

- a. Grantee shall provide the Department with quarterly reports of Project activity, entering the required Project information directly into a database required by the Department.
- b. Additionally, Grantee shall certify on each Request for Payment form, attached hereto as **Exhibit B** and incorporated herein, that all information provided in the database is true and accurate, updates to the database have been maintained, and all Project activity complies with applicable law and the terms of this Agreement.
- c. Grantee hereby acknowledges that failure to perform and/or certify updates to the database will jeopardize the reimbursement of funds. The Department shall give Grantee a minimum of fourteen (14) days' advance written notice of any changes to the information the Grantee is required to report.
- d. At the Department's discretion, all reports required hereunder may be directed to and facilitated through an electronic database.
- e. Quarterly reports shall be due on the last day of the month, that is, 30 days prior to the end of the quarter following the execution of this Agreement by the Department and ending during the quarter of the submission of the final request for reimbursement for the Project, or the following quarter. Quarterly reports shall be in the form required by **Exhibit C**, attached hereto and incorporated herein by reference.

B. Requests for Additional Information/Project Inspection

- a. During the term of this Agreement and the Record Retention Period, the Department may:
 - i. Request additional information regarding the Project as it deems necessary and
 - ii. Conduct on-site inspections of the Project at reasonable times and upon reasonable notice.
- b. Grantee shall respond to such requests for additional information within the time established by the Department.

IX. REQUEST FOR PAYMENT PROCEDURES

A. Grantee shall request payment by submitting the form attached hereto as **Exhibit B**

B. Payment requests are subject to the following procedures:

- a. Each Request for Payment must be in accordance with the Project Budget and contain proof of payment by the Grantee or liabilities incurred by the Grantee.
 - i. Proof of payment must demonstrate the validity of an expenditure or liabilities incurred by Grantee.

- ii. However, Grantee may be reimbursed for unpaid liabilities only if the Department, in its sole and absolute discretion, agrees to do so and in accordance with any special conditions imposed by the Department.
- b. Obligated but unpaid invoices received by Grantee from third-party contractors or vendors may be reimbursed if the invoices comply with the provisions of this Agreement.
 - i. The Grantee shall make payment to those contractors or vendors within five (5) business days from the date of receiving reimbursement from the Department or in a shorter period than the Department may prescribe in writing.
 - ii. The Department reserves the right to make such payments directly to the contractors or vendors as a special condition under this Agreement.
 - iii. The Grantee is required to certify to the Department proof of payment to the third-party contractor or vendor within five (5) business days from the date the Department reimburses the Grantee.

B. Until the Project is fully planned, designed, and all necessary procurements identified in the Project Budget are completed, Grantee's reimbursements will be limited to the planning, design, and procurement costs outlined in the Project Budget. Once the planning, designing, and procuring stages are complete, the Grantee must obligate at least ten percent (10%) of the Adjusted Appropriation Amount within one (1) year and must have utilized at least eighty-five percent (85%) of the Adjusted Appropriation Amount six (6) months before the reversion date.

C. Deadlines. Grantee shall submit requests for Payments to the Department on the earlier of:

- a. Immediately as Grantee receives them, but at a maximum of thirty (30) days from when Grantee incurred the expenditure or liability; or
- b. Twenty (20) days from the date of Early Termination or Reversion Date for expenditures or liabilities incurred before the Early Termination date or Reversion Date.

D. Grantee's failure to abide by the requirements set forth in Article II and Article IX herein may result in the denial of its Request for Payment. Department reserves the right to reject a payment request for the Project unless and until it is satisfied that the expenditures or liabilities are for permissible purposes within the meaning of the Project Description, identified within the Project Budget, and that the Grantee is otherwise in compliance with this Agreement.

- a. Department's authority to reject any Request for Payment is in addition to, and not in lieu of, any other legal or equitable remedy available to the Department under this Agreement, at law, or in equity.

X. PROJECT CONDITIONS AND RESTRICTIONS

A. The following general conditions and restrictions shall apply to the Project:

- a. The Project's funds must be spent in accordance with all applicable state laws, regulations, policies, and guidelines, including, but not limited to, the State Procurement Code.
- b. The Project's expenditures and liabilities must be accounted for in accordance with the State's Model Accounting Practices, as amended from time to time.
- c. The Project must be implemented in accordance with the New Mexico Public Works Minimum Wage Act, Section 13-4-10 through 13-4-17 NMSA 1978, as applicable.
- d. The Project must provide a public benefit above and beyond any incidental benefit to private entities in accordance with applicable law, including, but not limited to, Article IX, Section 14 of the Constitution of the State of New Mexico.
- e. Without prior written approval from the Department and State Board of Finance, for the useful life of any asset purchased under this Agreement, Grantee shall not convert any property acquired, built, renovated, repaired, designed, or developed with Project funds to uses other than those specified in the Project Description.
 - i. In addition to other remedies available at law or in equity, any disposal or conversion of property acquired, built, renovated, repaired, designed, or developed with Project funds without the Department's and the Board of Finance's express written approval will trigger the Department's right to reimbursement from Grantee of the Appropriated Amount, transfer proceeds from any disposition of property to the State, or otherwise provide consideration to the State for the Appropriated Amounts.
- f. Grantee shall comply with all applicable federal and state laws, rules, and regulations pertaining to civil rights and equal employment opportunity.
 - i. In accordance with all such laws, rules, and regulations, the Grantee agrees to assure that no person shall, on the grounds of race, color, national origin, sex, sexual preference, age, or handicap, be excluded from participation in the Project, use of the Project, employment with Grantee, or otherwise be denied benefits/subject to discrimination for any activity performed under this Agreement.
- g. Where the Department, in its sole and absolute discretion, determines Grantee has failed to comply with the above conditions and restriction, Grantee agrees to take appropriate steps to correct any deficiencies immediately. The Grantee's failure to implement such appropriate steps within a reasonable time, but no longer than thirty (30) days after notice from the Department, constitutes a breach of this Agreement and grounds for Early Termination.

XI. REPRESENTATIONS AND WARRANTIES

A. Reliance by Department.

- a. Grantee expressly acknowledges that the Department relies on the representations and warranties made by Grantee in this Agreement. Grantee acknowledges that such representations and warranties are a material inducement for the Department to enter into this Agreement and provide the Appropriated Amount.
- b. Grantee shall ensure all representations and warranties provided herein are true, accurate, and complete as of the date of the Effective Date and shall remain so throughout the Term of this Agreement. Grantee is responsible for promptly notifying the Department in writing of any changes or inaccuracies in the representations and warranties contained herein.

B. Grantee hereby represents and warrants the following:

- a. Grantee has taken all necessary steps to attain the legal authority to receive and expend the Project's funds.
- b. Grantee has duly authorized this Agreement, and the person executing it has authority to do so. Once executed by Grantee, this Agreement shall constitute a binding obligation of Grantee, enforceable according to its terms.
- c. Grantee's obligations hereunder do not conflict with any law, ordinance, or resolution applicable to Grantee, Grantee's charter (if applicable), or any judgment or decree to which Grantee is subject.
- d. Grantee has independently confirmed that the Project Description, including, but not limited to, the Appropriated Amount and Reversion Date, is consistent with the underlying appropriation in law.
- e. Grantee's governing body has duly adopted or passed as an official act a resolution, motion, or similar action authorizing the person identified as the official representative of the Grantee to sign and submit Requests for Payment on behalf of Grantee.
- f. Grantee will abide by New Mexico laws regarding conflicts of interest, governmental conduct, and whistleblower protection.
 - i. Grantee agrees explicitly none of its officers or employees or its designees or agents, no member of the governing body, and no other public official of Grantee who exercises any function or responsibility with respect to this Agreement, shall have any interest, direct or indirect, in any contract or subcontract, or the proceeds thereof, for the Project.
 - ii. Further, Grantee will require all of its contractors to incorporate the language set forth in this paragraph prohibiting conflicts of interest in all subcontracts.
- g. No funds have been paid or will be paid, by or on behalf of the Grantee, to any person for influencing or attempting to influence an officer or employee of the State, any agency, or body in connection with the awarding of any Third Party Obligation.
 - i. Grantee will require certifying language prohibiting lobbying to be included in the award documents for all subawards, including subcontracts, loans,

and cooperative agreements.

- C. Consequences of False or Misleading Representations. If any representation or warranty made by Grantee is found to be false or misleading, the Department shall have the right to exercise any or all of the following remedies:
- a. **Termination of Agreement:** Department may terminate this Agreement immediately upon written notice to the Grantee.
 - b. **Repayment of Grant Funds:** Grantee shall repay all Appropriated Amounts disbursed under this Agreement, upon demand by the Department.
 - c. **Other Remedies:** Department may pursue any other remedies available at law or in equity.
- D. Survival of Representations and Warranties. The representations and warranties made by the Grantee shall survive the Early Termination or expiration of this Agreement.

XII. PROJECT RECORDS

- A. Grantee shall be strictly accountable for receipts and disbursements relating to the Project's funds. The Grantee shall follow generally accepted accounting principles and the State's Model Accounting Practices and, if feasible, maintain a separate bank account or fund with a separate organizational code to ensure separate budgeting and accounting of the funds.
- B. For six (6) years following the Project's completion ("**Record Retention Period**"), Grantee shall maintain all Project-related records, including, but not limited to, all financial records, requests for proposals, invitations to bid, selection and award criteria, contracts and subcontracts, advertisements, minutes of pertinent meetings, as well as records sufficient to fully account for the amount and disposition of the Appropriated Amount from all sources budgeted for the Project, the purpose for which such funds were used, and such other records as the Department may prescribe.
- C. Grantee shall make all Project records available to the Department, the Department's Independent Public Accountant, and the New Mexico State Auditor upon request. With respect to the funds that are the subject of this Agreement, if the State Auditor or the Department finds any funds were improperly expended, Grantee shall be required to reimburse the State all amounts found to be improperly expended.

XIII. ARTICLE XII. IMPROPERLY REIMBURSED FUNDS

If the Department determines part or all of the Appropriation Amount was improperly reimbursed to Grantee, including but not limited to funds reimbursed to Grantee based upon fraud, mismanagement, misrepresentation, misuse, violation of law by the Grantee, after ten (10) days' notice to Grantee and the opportunity to return such funds to the Department, the

Department may offset any funds due to Grantee from the State, until the Appropriation Amount is fully repaid.

XIV. ARTICLE XIII. LIABILITY

Neither Party shall be responsible for liability incurred as a result of the other Party's acts or omissions in connection with this Agreement. Any liability incurred in connection with this Agreement is subject to immunities and limitations of the New Mexico Tort Claims Act.

XV. ARTICLE XIV. SCOPE OF AGREEMENT

This Agreement constitutes the entire and exclusive agreement between the Parties concerning the subject matter hereof. The Agreement supersedes all prior or contemporaneous agreements, understandings, discussions, communications, and representations, written or verbal.

XVI. REQUIRED NON-APPROPRIATIONS CLAUSE

- A. Grantee acknowledges and agrees to include a "non-appropriations" clause in all contracts between it and other parties that are (i) funded in whole or part by funds made available under this Agreement and (ii) entered into after the effective date of this Agreement that states:
 - a. "The terms of this Agreement are contingent upon sufficient appropriations and authorization being made by the Legislature of the State of New Mexico ("**Legislature**") for the performance of this Agreement.
 - b. If the Legislature does not make sufficient appropriations and authorization, City of Santa Fe may immediately terminate this Agreement by giving Contractor written notice of such termination.
 - c. City of Santa Fe's decision as to whether sufficient appropriations are available shall be final and accepted by the Contractor. Contractor hereby waives any rights to assert an impairment of contract claim against the City of Santa Fe or the State of New Mexico in the event of immediate or Early Termination of this Agreement by the City of Santa Fe or the State Department of Finance and Administration."

XVII. REQUIRED TERMINATION CLAUSE

- A. Grantee acknowledges and agrees to include the following termination clause in all contracts that are (i) funded in whole or part by funds made available under this Agreement and (ii) entered into after the effective date of this Agreement:
 - a. "This contract is funded in whole or in part by funds made available by the State of New Mexico ("**State**"). Should the State terminate its Agreement with City of

Santa Fe, City of Santa Fe may terminate this contract immediately by providing Contractor written notice of such termination.

- b. In the event of termination pursuant to this paragraph, City of Santa Fe only liability to Contractor shall be for goods and services delivered and accepted prior to the termination date.”

XVIII. COMPLIANCE WITH UNIFORM FUNDING CRITERIA

A. Throughout the term of this Agreement, Grantee shall:

- a. Submit all reports of annual audits and agreed-upon procedures required by § 12-6-3(A)-(B), NMSA 1978 by the due dates established in § 2.2.2 NMAC, reports of which must be a public record pursuant to § 12-6-5(A), NMSA 1978 within forty-five (45) days of delivery to the State Auditor;
- b. Have a duly adopted budget for the current fiscal year approved by its budgetary oversight agency (if any);
- c. Timely submit all required financial reports to its budgetary oversight agency (if any); and
- d. Use accounting methods and procedures consistent with Generally Accepted Accounting Principles and the State’s Model Accounting Principals to expend the Appropriated Amount in accordance with applicable law and account for and safeguard Project funds and assets acquired with Project funds.

B. In the event Grantee fails to comply with the requirements of subparagraph A of this Article XVIII, Department may take one or more of the following actions:

- a. Suspend new or further obligations pursuant to Article VI(A) of this Agreement;
- b. Require the Grantee to develop and implement a written corrective action plan pursuant to Article VI(D) of this Agreement to remedy the non-compliance;
- c. Impose special conditions to address the non-compliance by giving Grantee notice of such special conditions in accordance with Article III of this Agreement;
 - i. The Parties agree that any special conditions imposed to address non-compliance shall be incorporated into this Agreement, through **Exhibit D**, upon notice to Grantee, without need for formal amendment of this Agreement;
 - ii. Special conditions shall be binding and effective on the date that notice is deemed to have been given pursuant to Article III or
- d. Terminate this Agreement pursuant to Article V(A) of this Agreement.

XIX. SEVERANCE TAX AND GENERAL OBLIGATION BONDS

A. Grantee acknowledges and agrees that the underlying appropriation for the Project may originate from the issuance of tax-exempt severance tax bonds or general obligation bonds by the State. Proceeds from such bonds are administered by the New Mexico State Board of Finance (“**SBOF**”), an entity separate and distinct from the Department.

- a. Grantee acknowledges and agrees:
 - i. It is Grantee's responsibility to determine through SBOF what (if any) conditions are currently imposed on the Project;
 - ii. Department's failure to inform Grantee of an SBOF-imposed condition does not affect the validity or enforceability of the condition;
 - iii. The SBOF may in the future impose further or different conditions upon the Project;
 - iv. All SBOF conditions are attached to the Project and Appropriation Amount without the need for formal amendment of this Agreement;
 - v. All applicable SBOF conditions must be satisfied before the SBOF will release to the Department funds subject to the condition(s) and
 - vi. The Department's obligation to reimburse Grantee from the Project is expressly contingent upon the satisfaction of the then-current SBOF conditions.

B. Grantee acknowledges and agrees SBOF may, at its sole and absolute discretion, require reimbursement or remove eligibility for bond proceeds for the Project if the Project doesn't proceed sufficiently.

- a. Grantee must comply with the requirement to encumber five percent (5%) of Project funds within six months of bond issuance as certified by Grantee in the Bond Questionnaire and Certification documents submitted to the SBOF.
- b. Failure to comply may result in the reassignment of the bond proceeds. Upon reassignment of bond proceeds, this Agreement will be suspended until the entity has demonstrated readiness as determined by the SBOF and the Department.

C. Grantee acknowledges and agrees that this Agreement is subject to the SBOF's Bond Project Disbursements rule, § 2.61.6, NMAC, as may be amended from time to time or re-codified.

XX. GENERAL PROVISIONS

A. Assignment: Grantee's rights and obligations under this Agreement are personal and may not be transferred or assigned without the prior written consent of the State. Any attempt at assignment or transfer without such consent shall be void. Any assignment or transfer of Grantee's rights and obligations approved by the State shall be subject to the provisions of this Agreement.

B. Subcontractors: Grantee shall not enter any subgrant or subcontract in connection with its obligations under this Agreement without the prior written approval of the State. Upon request, Grantee shall submit to the Department a copy of each such subgrant or subcontract.

- C. **Binding Effect:** Except as otherwise provided, all provisions of this Agreement, including the benefits and burdens, shall extend to and be binding upon the Parties' respective successors and assigns.
- D. **Authority:** Each Party represents and warrants to the other that the execution and delivery of this Agreement and the performance of such Party's obligations have been duly authorized.
- E. **Captions and References:** The captions and headings in this Agreement are for the convenience of reference only and shall not be used to interpret, define, or limit its provisions. All references in this Agreement to sections (whether spelled out or using the § symbol), subsections, exhibits, or other attachments are references to sections, subsections, exhibits, or other attachments contained herein or incorporated as a part hereof, unless otherwise noted.
- F. **Counterparts:** This Agreement may be executed in multiple, identical, original counterparts, each of which shall be deemed to be an original, but all of which, taken together, shall constitute the same agreement.
- G. **Digital Signatures:** If any signatory signs this agreement using a digital signature in accordance with the State Policies regarding the use of digital signatures, then any agreement or consent to use digital signatures within the electronic system through which that signatory signed shall be incorporated into this Agreement by reference.
- H. **Modification:** Except as otherwise provided in this Agreement, any modification to this Agreement shall only be effective if agreed to in a formal amendment, properly executed and approved in accordance with applicable New Mexico law and State fiscal policies and rules. Modifications permitted under this Agreement, other than Agreement amendments, shall conform to the policies issued by the State.
- I. **Statutes, Regulations, Fiscal Rules, and Other Authority:** Any reference in this Agreement to a statute, regulation, policy, or other authority shall be interpreted to refer to such authority then current, as may have been changed or amended after the Effective Date of this Agreement.
- J. **External Terms and Conditions:** Notwithstanding anything to the contrary herein, the State shall not be subject to any provision included in any terms, conditions, or agreements appearing on Grantee's or a subcontractor's website or any provision incorporated into any click-through or online agreements related to the Work unless that provision is specifically referenced in this Agreement.
- K. **Severability:** The invalidity or unenforceability of any provision of this Agreement shall not affect the validity or enforceability of any other provision of this Agreement, which shall remain in full force and effect, provided that the Parties can continue to perform their obligations under this Agreement in accordance with its intent.

- L. **Survival of Certain Agreement Terms:** Any provision of this Agreement that imposes an obligation on a Party after the termination or expiration of this Agreement shall survive the termination or expiration of this Agreement and shall be enforceable by the other Party.
- M. **Third Party Beneficiaries:** Except for the Parties' respective successors and assigns described in this Agreement, it does not and is not intended to confer any rights or remedies upon any person or entity other than the Parties. Enforcement of this Agreement and all rights and obligations hereunder are reserved solely to the Parties. Any services or benefits that third parties receive as a result of this Agreement are incidental to this Agreement and do not create any rights for such third parties.
- N. **Waiver:** A Party's failure or delay in exercising any right, power, or privilege under this Agreement, whether explicit or by lack of enforcement, shall not operate as a waiver, nor shall any single or partial exercise of any right, power, or privilege preclude any other or further exercise of such right, power, or privilege.
- O. **Standard and Manner of Performance:** Grantee shall perform its obligations under this Agreement in accordance with the highest standards of care, skill, and diligence in Grantee's industry, trade, or profession.
- P. **Licenses, Permits, and Other Authorizations:** Grantee shall secure, prior to the Effective Date, and maintain at all times during the term of this Agreement, at its sole expense, all licenses, certifications, permits, and other authorizations required to perform its obligations under this Agreement and shall ensure that all employees, agents, and subcontractors secure and maintain at all times during the term of their employment, agency or subcontractor, all license, certifications, permits and other authorizations required to perform their obligations in relation to this Agreement.
- Q. **Publicity:** Any Publicity regarding the subject matter of this Agreement may not be released without prior written approval from the Department. For purposes of this agreement, "**Publicity**" means notices, informational pamphlets, press releases, email responses, research, reports, signs, and similar public notices prepared by or for the Grantee or jointly with others.
- a. Grantee shall obtain written approval prior to issuing any press release or making any public announcement regarding this agreement. Grantee agrees to obtain approval of the Department in advance with respect to all Public Relations, all communications with media, or all communications with any other member of the public with respect to this agreement, except to acknowledge that an agreement does exist.

- b. For purposes of this agreement, "Public Relations" includes community relations and means those activities dedicated to maintaining the Department's image or maintaining or promoting understanding and favorable relations with the community or public at large or any segment of the public.
- c. Violations of either Article XX (Q)(a) or (b) shall constitute a material Breach of Agreement.

R. Data Sharing: The State intends to secure and collate specific data generated by Grantee under this Agreement to use in support of the State's organizational, policy-making, and management of public resource functions. State, in accordance with **Exhibit E**, attached hereto and incorporated herein by reference, reserves the right to require Grantee and/or its subcontractors to provide specific data relevant to the above-listed functions. Data provided by Grantee may be

incorporated into existing or future developed State integrated analysis tools or databases, including but not limited to geographic information system (GIS) networks and databases accessible by the public. Dissemination of data collected may include historical data and projections based on such historical data.

- a. To the extent any data transferred as part of this Agreement is legally determined to be the property of Subrecipient or its subcontractors, Subrecipient and/or its subcontractors grants State a nonexclusive, fully paid-up right and license to reproduce, use, distribute, do derivative works based on, and archive data transferred as part of this Agreement.

S. Venue and Choice of Law: This Agreement shall be governed by and construed in accordance with the laws of the State of New Mexico, without regard to any conflict of law provisions. Any legal suit, action, or proceeding arising out of or related to this Agreement shall be instituted exclusively in the district courts located in Santa Fe, New Mexico. The Parties hereby irrevocably submit to the exclusive jurisdiction and venue of such courts in any such suit, action, or proceeding. The Parties waive any objection to the laying of the venue of any such suit, action, or proceeding in the district courts of Santa Fe, New Mexico, and irrevocably waive and agree not to plead or claim in any such court that any such suit, action, or proceeding brought in any such court has been brought in an inconvenient forum.

[SIGNATURE PAGE AND EXHIBITS FOLLOW]
[THIS SPACE LEFT BLANK INTENTIONALLY]

IN WITNESS WHEREOF, the parties have duly executed this Agreement as of the Department's date of execution.

APPROVED BY DEPARTMENT:

Cabinet Secretary, Wayne Propst:

Signature

Date

Chief Financial Officer, Mackie Romero:

Signature

Date

Local Government Division Director, Cecilia Mavrommatis:

Signature

Date

AS TO LEGAL FORM AND SUFFICIENCY

General Counsel's Office:

Signature

(Print Name)

(Title)

APPROVED BY GRANTEE:

Entity Name

Official with Authority to Bind Grantee:

Signature

(Print Name)

(Title)

Date

Fiscal Officer or Chief Financial Officer:

Signature

(Print Name)

(Title)

Date

As To Legal Form And Sufficiency

Kevin L. Nault
Kevin L. Nault (Jan 16, 2026 08:45:03 MST)

Signature

Kevin L. Nault

Assistant City Attorney

(Print Name)

(Title)

Jan 16, 2026

Date

EXHIBIT B
Notice of Department's Obligation Form

NOTICE OF OBLIGATION TO REIMBURSE GRANTEE
EXHIBIT B

Notice of Obligation to Reimburse Grantee # _____

DATE: _____

TO: Department Representative: _____, Grant Manager

FROM: Grantee Entity: _____

Grantee Official Representative: _____

SUBJECT: Notice of Obligation to Reimburse Grantee

Grant Number: _____

Grant Termination Date: _____

As the designated representative of the Department for Grant Agreement number _____ entered into between Grantee and the Department, I certify that the Grantee has submitted to the Department the following third party obligation executed, in writing, by the third party's authorized representative:

Vendor or Contractor: _____

Third Party Obligation Amount: _____

Vendor or Contractor: _____

Third Party Obligation Amount: _____

I certify that the State is issuing this Notice of Obligation to Reimburse Grantee for permissible purposes within the scope of the project description, subject to all the terms and conditions of the above referenced Grant Agreement.

Grant Amount (Minus AIPP if applicable): _____

The Amount of this Notice of Obligation: _____

The Total Amount of all Previously Issued Notices of Obligation: _____

The Total Amount of all Notices of Obligation to Date: \$ 0.00 _____

Note: Contract amounts may exceed the total grant amount, but the invoices paid by the grant will not exceed the grant amount.

Department Rep. Approver: _____

Title: Grant Manager _____

Signature: _____

Date: _____

1 Administrative and/or Indirect Cost – generally, the legislation authorizing the issuance of bonds prohibits the use of its proceeds for indirect expenses (e.g. penalty fees or damages other than pay for work performed, attorney fees, and administrative fees). Such use of bond proceeds shall not be allowed unless specifically authorized by statute.

Revised 7/2025

[THIS SPACE LEFT BLANK INTENTIONALLY]

EXHIBIT C

Special Conditions (If Fiscal Agent Required or Anti Donations Issues Exist)

**OPTIONAL EXHIBIT C
SPECIAL CONDITIONS**

The capital outlay oversight requires grantees’ accounting methods and procedures, including their internal control framework, to be scrutinized, so as to safeguard State capital outlay appropriations and assets acquired with such appropriations.

This Capital Outlay Special Grant Condition(s) **Exhibit C** is necessary pursuant to § 6-3b-1 et seq., NMSA 1978 (Public Finance Accountability Act) and MAPS Fin 9.2, due to the Grantees’ material weaknesses, significant deficiencies, or findings that raised concerns as to the ability to expend grant funds in accordance with applicable law in the organization’s FY[20XX] audit. The Special Conditions identified below apply to the authorized agent, [insert the Grantee or Fiscal Agent name].

Procurement - All purchases or contracts the Grantee enters that shall use funding from the Department capital appropriations grant must be approved by the Department prior to the initiation of implementing purchasing documents. The Grantee shall receive such prior approval via official correspondence from the Department, which may be through letter or email. The Grantee shall submit the following to the Department in pursuit of prior approval: purchasing policies and procedures, CFO certification, documentation of management and program approval, policies and procedures governing purchasing and contracting, a copy of the current procurement and contracting policies, and documentation regarding informing staff responsible for purchasing and contracting on such policies and procedures.

Budget - Provide documentation of approval of your current budget from DFA Local Government or other authoritative agency. Provide policies and procedures on who is responsible for and how annual budgets (expenditures and revenue) are established, monitored and adjusted. Provide a corrective action plan on how budget issues identified in your audit will be/have been addressed. Also include documentation on how staff responsible for budgeting is informed on budget policies and procedures.

Capital Assets - Provide a complete list of inventory including inventory control numbers and current location. Provide policies and procedures on capital assets and inventory and specify how the proposed purchased items will be included, tagged, and tracked in capital asset inventory. Also include documentation on how staff responsible for capital assets is informed on capital asset policies and procedures.

Travel and Per Diem - Provide policies and procedures on travel and per diem. Also include how staff who travel and those responsible for travel reimbursement are informed on travel and per diem policies and procedures.

Timely Audits – Provide policies and procedures on annual audits. Provide documentation on how and who is responsible for insuring that annual audits are completed timely. Also include documentation on how staff responsible for the annual audit is informed on audit policies and procedures.

Cash Management – policies and procedures on cash management of federal funds. Provide procedures used to draw and disburse federal funds. Provide procedures to reconcile draw amounts, deposits and disbursements; and to prepare federal cash reporting documents to ensure compliance with federal regulations.

The <Grantee> was required to, and has provided sufficient documentation regarding [insert specific names of the Special Condition(s)], as referenced in the <Grantee>’s [20XX] Audit file. Therefore, the criteria to enter into this agreement have been met.

[THIS SPACE LEFT BLANK INTENTIONALLY]

EXHIBIT D

Project Budget Worksheet *

*(Provided separately when grant agreement issued to Grantee)

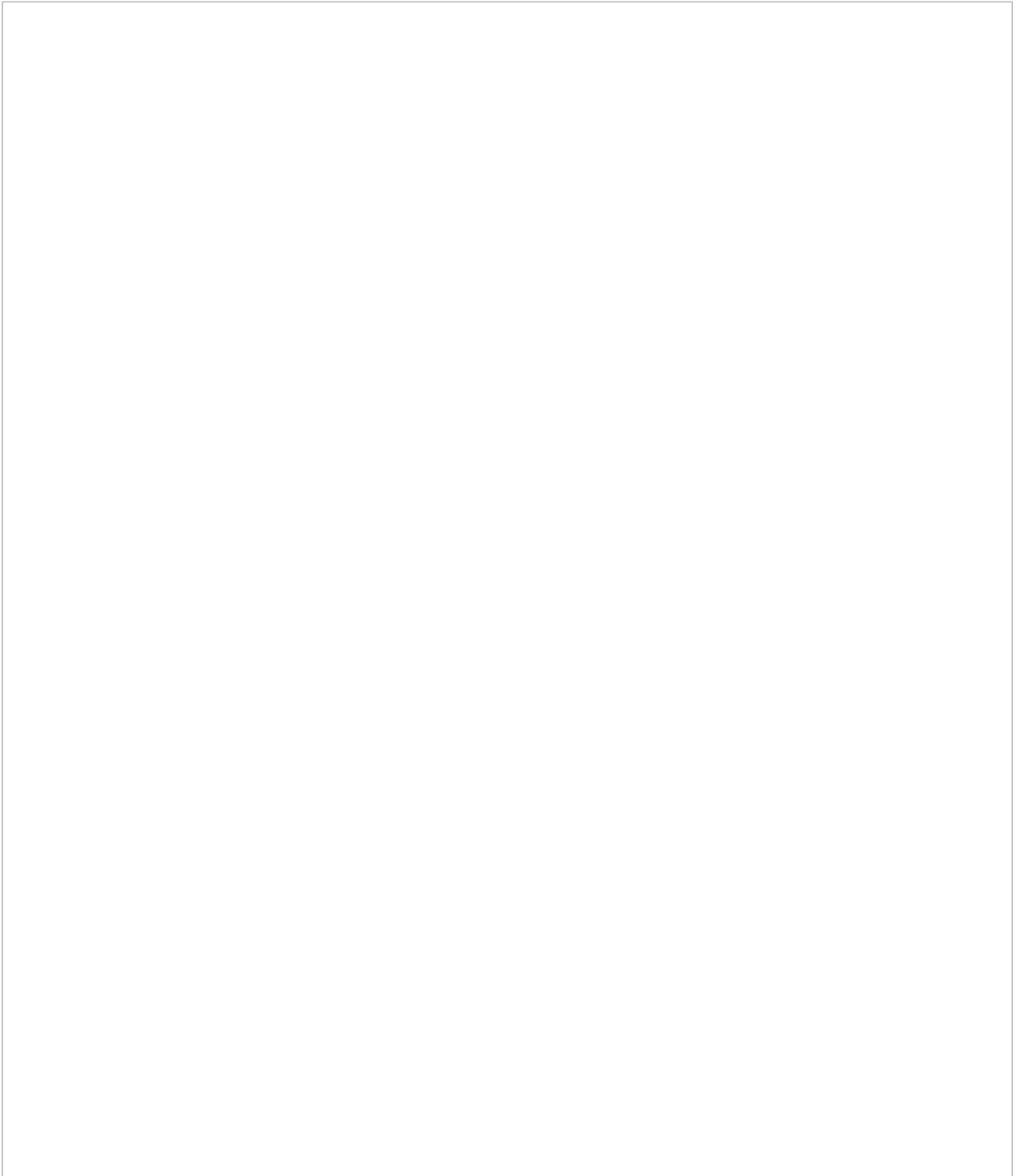

[THIS SPACE LEFT BLANK INTENTIONALLY]

EXHIBIT E
Data Sharing Provisions

Exhibit E

Data Sharing Provisions for New Mexico Capital Outlay Agreements

I. Introduction:

This Data Sharing Provisions Exhibit ("Exhibit") is incorporated into the New Mexico Capital Outlay Agreements ("Agreements") between the State of New Mexico ("State") and [Insert Partner Name] ("Partner"). This Exhibit outlines the terms and conditions under which data will be shared between the Parties to ensure compliance with New Mexico state laws and regulations, focusing on data privacy, security, and compliance.

II. Definitions:

- a. **Authorized User:** An employee, agent, assign, representative, independent contractor, or other person or entity authorized by Partner or State to access, use, or disclose information through this exhibit.
- b. **Confidential Information:** All data or information shared in confidence, with the expectation that it will not be disclosed in an identifiable form. This includes data that is exempt from public disclosure under the New Mexico Inspection of Public Records Act (§ 14-2-1 et seq. NMSA 1978) or other relevant laws.
- c. **Data Storage:** Electronic media that hold recorded information.
- d. **Data Transmission:** The process of moving information over a network from its source to one or more destinations.
- e. **Direct Identifier:** Records or data containing personal identifiers such as names, addresses, and social security numbers.
- f. **Disclosure:** Permission to access, release, transfer, or otherwise communicate confidential information by any means to any third party, except as authorized by the Party that controls the record.
- g. **Encryption** involves using algorithms to encode data, rendering it unreadable without a specific key. It may be necessary during data transmission and/or storage.
- h. **Information:** Any data, figures, statistics, or other facts provided or learned about someone or something, including Confidential Information, that may be legally transmitted under this Exhibit.
- i. **Limited Dataset:** A data file that omits Direct Identifiers.
- j. **Protected Personally Identifiable Information:** Sensitive personal details such as social security numbers and financial account numbers, with specific exclusions as outlined in the Agreements.

III. Purpose:

The purpose of this exhibit is to promote transparency, facilitate information sharing between the parties, support better policy and decision-making, and enhance public services through collaborative

data analysis from various sources.

IV. Use of Information:

- a. Use of Information obtained or created under this exhibit shall be strictly limited to the purposes stated herein and in the agreements. The parties agree not to sell Information to third parties or use it for commercial, solicitation, or political purposes.
- b. Each Party shall serve as the custodian of the Information and comply with all conditions for its use, including security measures to prevent unauthorized access.
- c. The Parties shall follow all relevant federal and state laws and regulations governing the use of such Information.

V. Safeguarding Information:

- a. Confidentiality: Access to Confidential Information shall be limited to the minimum necessary to accomplish the purposes of this Exhibit. Authorized Users must adhere to the confidentiality requirements.
- b. Security: Security practices shall comply with the requirements of the New Mexico Department of Information Technology Act and related regulations. The Parties agree to notify each other within three business days of any suspected or actual security breach.
- c. Information Storage and Transmission: Data Storage and Transmission shall take place on an encrypted server with appropriate security controls.

VI. Re-Disclosure of Information:

The Parties agree not to disclose Information except as required by law or with prior written approval of the other Party. If there is a public records request, the Party receiving it shall notify the other Party within three business days.

VII. Ownership of Information:

Legal title to Information shall remain with the provider. The Partner grants the State a royalty-free, non-exclusive, non-transferable license to use the Information in furtherance of the purposes outlined in this Exhibit.



City of Santa Fe New Mexico

Finance Department

Project Ledger Request Form



Date of Request: 12/16/2025

Project Title: Shelby Street Pedestrian Bridge

Project Type: CIP Grant Internal Tracking

Department: Public Works - Parks Project Manager: Scott Overlie Ext: 231-6194

Project Date Range: 12/16/2025 to 04/11/2027 Create Fixed Asset

Project ID: PWD2535518

Grant ID: S2642

Approved By: ERIKA LUJAN
ERIKA LUJAN (Dec 30, 2025 14:16:18 MST)

CT (Finance Use Only)

Multi-Funding (complete all funding sources, should equal 100%)

Funding Source: NMDFA 25-J5984 % of Funding: _____

MUNIS ORG: 3559980 MUNIS OBJ: 490210 Awarded Amount: \$260,000

Funding Source: _____ - % of Funding: _____

MUNIS ORG: _____ MUNIS OBJ: _____ Awarded Amount: _____

Expense String Phase:

A project must have at least one phase identified, this can be used as an additional level of tracking, for example, CIP - Design, Construction, etc. For Grants can be used as reimbursable types, such as transportation, salaries.

(You can create more than one phase and you can default MUNIS ORGs and OBJs, optional)

Phase: WIP Construction MUNIS ORG: 3559980 MUNIS OBJ: 572970

Grants Only (list all grants if applicable):

Grantor Name: NM DFA 25-J5984 Awarded Amount: \$260,000

AR Charge Code: 3559980.490210 Grant funds multiple projects
(Complete a form for each project)

Grantor Id: 700007 Federal CFDA (if applicable): _____

Grantor Name: _____ Awarded Amount: _____

AR Charge Code: _____ Grant funds multiple projects
(Complete a form for each project)

Grantor Id: _____ Federal CFDA (if applicable): _____

(If grants please provide all grant award documents with form) Attached Grant Documentation

Log # {Finance use <u>only</u> }:	
Journal # {Finance use <u>only</u> }:	

City of Santa Fe, New Mexico BUDGET AMENDMENT RESOLUTION (BAR)

DEPARTMENT / DIVISION NAME				DATE	
Public Works / Parks				12/17/2025	
ITEM DESCRIPTION	ORG	OBJECT	PROJECT	INCREASE	DECREASE
<u>EXPENDITURES</u>				<i>{enter as <u>positive</u> #}</i>	<i>{enter as <u>negative</u> #}</i>
WIP Construction	3559980	572970	PWD2535518	260,000	
<u>REVENUES</u>				<i>{enter as <u>negative</u> #}</i>	<i>{enter as <u>positive</u> #}</i>
NMDFA 25-J5984 - Shelby Street Pedestrian Bridge	3559980	490210	PWD2535518	(260,000)	

JUSTIFICATION: *(use additional page if needed)*
 --Attach supporting documentation/memo

\$ - \$ -

DFA grant award (25-J5984) for Shelby Street Pedestrian Bridge in the total amount of \$260,000. Expires 4/11/2027.

<i>{Complete section below if BAR results in a net change to ANY Fund}</i>	
	Fund Balance
Fund(s) Affected	Increase/(Decrease)
TOTAL:	0

Carol Swenson Prepared By <i>{print name}</i> <i>Carol Swenson</i> Business Operations Manager  Department Director Signature	12/17/2025 Date	<i>{Use this form for Finance Committee/ City Council agenda items ONLY}</i>	<i>Andy Hopkins</i> Budget Officer Finance Director {≤ \$5,000} City Manager {≤ \$60,000}	Date Date Date
CITY COUNCIL APPROVAL				
City Council Approval Date: <input style="width: 100%;" type="text"/>				
Agenda Item #: <input style="width: 100%;" type="text"/>				



The Purchasing Memo

Date: January 6, 2026

To: Governing Body
Finance Committee
Public Utilities/ Public Works

From: Martin Valdez, ESD Fleet Manager 

Via: Jesse Roach, Interim Public Utilities Director 
Debora Trujillo, Environmental Services Division Director 

Subject: Purchase of Two (2) Roll-Off Collection Vehicles

Vendor Name: Rush Truck Centers of New Mexico, Inc.

Munis Vendor Number: 2011

ITEM AND ISSUE:

The Public Utilities Department (Environmental Services Division) requests review and approval for the purchase of **Two (2) Roll-Off Collections Vehicles** from **Rush Truck Centers of New Mexico, Inc.** The total purchase amount is **\$548,338.00**. The procurement will be made through the National Purchasing Cooperative (BuyBoard Contract #723-23) which expires November 30, 2026, to ensure competitive pricing and compliance with cooperative purchasing requirements.

BACKGROUND AND SUMMARY:

The Environmental Services División utilizes roll-off collection vehicles for the transport and disposal of large waste containers from commercial and municipal customers. Two (2) of our existing units in the fleet have reached the end of their useful service life and are considered non-viable due to age, high maintenance costs, and frequent mechanical failures.

Replacing these aged vehicles with new roll-off collection units will improve operational reliability, reduce maintenance expenses, and support the department's ability to maintain efficient and uninterrupted solid waste collection services.

PRIOR APPROVALS AND SUPPORTING INFORMATION:

FUNDING SOURCE:

Fund Name/Number: ESD Enterprise Fund / Fund 510

Munis Org Name/Number: ESD Commercial Collections / 5100332

Munis Object Name/Number: Vehicles > 1.5 / 571000

Budget Officer / Designee: Andy Hopkins Date: 01/08/2026

Budget Officer Comment/Exceptions: _____

PROCUREMENT METHOD:

The procurement method used was:

National Purchasing Cooperative Contract #723-23, Exp November 30, 2026

Chief Procurement Officer (CPO) / Designee: [Signature] Date: 01/09/2026

CPO Comment/Exceptions: 13-1-135 - BuyBoard Coop - Please send this to Assests so Rebecca can track

ASSOCIATED APPROVALS:

IT Components included? Yes | No

Approval: _____ Title: _____ Date: _____

Comment/Exceptions: _____

Vehicles included? Yes | No

Approval: _____ Title: _____ Date: _____

Comment/Exceptions: approved via email as shown below!

Construction to City Facilities, Furniture, and/or Fixtures included? Yes | No

Approval: _____ Title: _____ Date: _____

Comment/Exceptions: _____

Is this an externally funded purchase? Yes | No

If yes, what is the issuing agency: _____

Approval: _____ Title: _____ Date: _____

Comment/Exceptions: _____

Is this a Capital Asset or Project? Yes | No

Project Ledger Number: _____

Approval: _____ Title: _____ Date: _____

Comment/Exceptions: _____

ATTACHMENTS:

- Vendor's Quote
- Vendor's Contract Info Summary
- National Purchasing Cooperative Contract Award Letter
- Contract #723-23 Pricing
- Fleet Maintenance Manager's Recusal Memo



Rush Truck Centers of New Mexico, Inc.

6521 Hanover Road NW
 Albuquerque, NM 87121
 505-875-3410

Customer Proposal Letter

City of Santa Fe Solid Waste
 2651 SIRINGO ROAD
 SANTA FE, NM 87505

BuyBoard Contract # 723-23

Thank you for trusting us with your business. Please review the proposal below, and if you approve, sign and return to us at your convenience. We look forward to working with you and will continue to do our best to earn your trust now and in the future.

VEHICLE INFORMATION

Year 2026 Make Peterbilt Model 567 Stock # TBD Serial # TBD

Quantity	<u>2</u>	Total
Truck Price per Unit	<u>\$ 273,819.00</u>	<u>\$ 547,638.00</u>
F.E.T. (Factory & Dealer Paid)	<u>\$ 0.00</u>	
Net Sales Price	<u>\$ 273,819.00</u>	<u>\$ 547,638.00</u>
Optional Extended Warranty(ies)		
State Sales Tax		
Documentary Fee	<u>\$ 350.00</u>	<u>\$ 700.00</u>
Total Sales Price	<u>\$ 274,169.00</u>	<u>\$ 548,338.00</u>
Trade Allowance (see DISCLAIMER Below)		
Deposit / Down Payment		
Unpaid Balance Due on Delivery	<u>\$ 274,169.00</u>	<u>\$ 548,338.00</u>

Sales Representative	Signature _____	Carlos Arreola	Date _____
		Printed Name	
Purchaser	Signature _____	Printed Name / Title	Date _____
Accepted by Sales Manager or General Manager	Signature _____	Printed Name	Date _____

Quote good until 2/6/2026 Note: The above Customer Proposal is a quotation only. Sale terms subject to approval of Sales Manager of Dealer.

DISCLAIMER: Any order based on this Proposal is subject to Customer executing Dealer's standard form Retail Sales Order and other required documents incorporating the above terms. Any documentary fees, FET, state tax, title, registration and license fees subject to adjustment and change. This Proposal is based upon Dealer's current and expected inventory, which is subject to change. Dealer is not obligated to retain any specific vehicles in stock, nor maintain any specific inventory levels. Dealer shall not be obligated to fulfill Proposal in event quoted vehicle(s) is not in stock or available within requested delivery schedule. **Manufacturer has reserved the right to change the price to Dealer of any vehicle not currently in Dealer's stock, without notice to Dealer. If a vehicle identified in this Proposal is not currently in Rush's stock at the time an order is placed by the Customer, Dealer reserves the right to change the vehicle price at any time to reflect any price increases imposed by the Manufacturer.** Dealer shall not be liable for any delay in providing or inability to provide Quoted Vehicle(s). Above listed Trade Value based upon current appraisal of Trade Vehicle(s). Dealer may adjust Trade Value of Trade Vehicle(s) to reflect changes in condition and/or mileage of Trade Vehicle(s) between date of current appraisal and acceptance of the Trade Vehicle by Customer.

(1) Includes subscription period for # of specified months. (2) Customer's use of RushCare Service is governed by the RushCare User Agreement located at <https://www.rushtruckcenters.com/rushcare-user-agreement>. (3) Customer's use of Telematics Services is governed by separate 3rd party license terms and Rush is not liable for the Telematic Service. (4) Gap Coverage is provided and administered by an independent 3rd party provider under a separate contract directly between Customer and the 3rd party provider.



501 Bernard Ave.
 Belen, NM 87002
 505-999-8726 or
 505-864-1010

Quote

Date	Quote #
1/06/2026	15104307

Name / Address
Rush Truck Center - Peterbilt Attn: Carlos Arreola

Contract / PO#

Valid For:

Item	Description	Qty	U/M	Cost	Total
Custom Fabricat...	SPARTAN ROLL OFF UNIT - MODEL SRO-60TK-OR (Tare Weight 6,800 lbs) <ul style="list-style-type: none"> • Hoist is 22' in length • Main Frame: 4" x 8" rectangular steel tubing, 1/2" wall thickness, 34.5" width • Sub Frame: 3" x 2" rectangular steel tubing 3/16" wall thickness • 4 per side, 4"OD x 3.5"L x 1.25" wall thick, 3.5" from top of rails, pins 2.5" OD with zerk fittings, extra pair of rollers • (2) - 6" bore x 4" chrome tube cylinders. 60,000 lb. combined rated lift capacity • Electric ('hot shift') for automatic transmission with P51, 28 - 32 GPM pump • Steel cable 7/8" x 85'(single cylinder) with 1" D Ring • Single cylinder reeving system, 7" bore x 4" x 90" Stroke chrome rod cylinder, center mounted • 40-gallon oil reservoir includes Thru-wall Sump Strainer and 10 Micron return oil filter • Stainless steel quarter fenders, standard • Full fenders, polypropylene composites, includes steel brackets • Air console with 2 ergonomic levers and air switch PTO controls • 18" x 36" heavy duty 10-gauge steel tool box with rear tarp storage & Lockable T handle • Maintenance-free manually collapsable heavy duty vehicle underride protection • Manual combo winches with safety yellow straps for container securement, both sides • 7" Diameter Quick Change Rear Roller • 2 adjustable stops for rail frames, stops holder brackets • Modern LED lighting conforms to safety standards 	1		56,500.00	56,500.00
Total					56,500.00



501 Bernard Ave.
 Belen, NM 87002
 505-999-8726 or
 505-864-1010

Quote

Date	Quote #
1/06/2026	15104307

Name / Address
Rush Truck Center - Peterbilt Attn: Carlos Arreola

Contract / PO#

Valid For:

Item	Description	Qty	U/M	Cost	Total
	<ul style="list-style-type: none"> • Automatic rack and pinion tarping system, includes control valves and levers on driver side • Labor & Installation 				
			Total		56,500.00



SPARTAN
TRUCK COMPANY, INC.



SRO 60

STANDARD SPARTAN FEATURES

-  **60,000 LB CAPACITY**
-  **HIGH SPEED SINGLE CYLINDER REEVING SYSTEM**
-  **MODULAR DESIGN & STANDARDIZED PARTS**
-  **LIGHTWEIGHT DESIGN**
-  **HIGH STRENGTH DURABLE COMPONENTS**
-  **EASIER TO SERVICE BY DESIGN**
-  **QUICK LEADTIMES**

 (818) 899-1111

 (818) 897-4366

 info@spartantruck.com

 Spartan Truck Company | 12266 Branford Street |

Sun Valley, CA 91352



For over 40 years, Spartan Truck Company has been the market leader in manufacturing waste equipment on the west coast. We are proud of our quick lead times, high quality components, & extremely durable Roll-Off systems, trailers and waste bodies.



Standard Specifications

Capacity	60,000 lbs
Rail type	Outside, Universal or In/Out
Cable	3/4" x 77'
Cable Strength	66,800 lbs
Hoist Cylinders	6" Bore, 4" Rod x 74" Stroke
Reeving Cylinder	7" Bore, 4" Rod x 90" Stroke
Outside Control Valve	Commercial VA35
Inside Control Valve	Air Operated Dual Levers
Operating Pressure	1800 PSI
Hydraulic Tank	40G with Sight & Temp gauge
Filtration	Suction Strainer & 10 Micron in tank return filter
PTO	Muncie Air Shift or Hot Shift
Pump	Muncie Direct Mount P51
Sheaves	10" with bronze bushings
Container Size	16' - 24'
Dump Angle	44 - 50 Degrees
Body Weight	6,200 lbs Approx
Frame Rails	4" x 10" x 3/8" Rectangular Tubing ASTM A500
Outside Frame	34 1/2" or 35 1/2"
Outside Rollers	(6) 5" OD x 3 1/2" with extractable pins.
ICC Bumper	Fixed or Manually moveable with locking pin
Fenders	Stainless Steel Polished Quarter Fenders
Lighting	Full LED
Electrical	One Piece plug and play harness
Tool Box	Steel Lockable 36" x 18" x 18" with Tarp Basket
Adjustable Stops	(2) Moveable Nose roller stops
Wear Strips	36" Rail mounted wear strips

SRO 60 Technical Specification

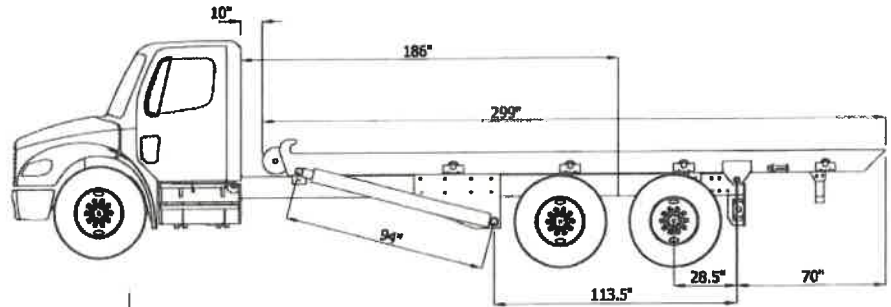

Tie Downs	Dual Ratchet Tiedowns with 3" Straps
Safety Props	Quick Release rail mounted props
Back up Alarm	Audible rear mounted alarm
Warning Lights	Cab mounted PTO and raised rail warning light
Lubrication	Zerk fittings on all wear points

Options

Hitch	Pull or Pup Trailer Hitch Package
Full Fenders	Minimizer Full Tandem Polypropylene
Tarping System	Fully Automatic with adjustable Gantry
Bin Locks	Automatic Container Securement Hooks
Ground Roller	7" Diameter Rear frame roller
Pusher Axle	13,200lb Steerable Hendrickson
On Board Scales	Scale Systems for Air Ride or Mechanical Suspensions



Vendor Contract Information Summary

Vendor Rush Truck Centers of Texas, L.P.
Contact Colton Kruse
Phone (830) 302-5219
Phone Extension 5219
Email krusec@rushenterprises.com
Vendor Website www.rushtruckcenters.com
TIN 74-2786264
Address Line 1 555 IH 35 South, Suite 500
Vendor City New Braunfels
Vendor Zip 78130
Vendor State TX
Vendor Country USA
Delivery Days 10
Freight Terms FOB Destination
Payment Terms NET30 see Exhibit A: Paym
Shipping Terms Freight prepaid by vendor and added to invoice
Ship Via Common Carrier
Designated Dealer No
EDGAR Received Yes
Service-disabled Veteran Owned No
Minority Owned No
Women Owned No
National No
No Foreign Terrorist Orgs Yes
No Israel Boycott Yes
MWBE No
ESCs All Texas Regions
States All States
Contract Name Medium and Heavy-Duty Trucks, Parts, and Maintenance Repair Services
Contract No. 723-23
Effective 12/01/2023
Expiration 11/30/2026
Accepts RFQs Yes
Service Fee Note Vehicle purchase orders are subject to a \$400 service fee

3/13/2024 8:22 AM



October 9, 2023

Sent Via Email: krusec@rushenterprises.com

Colton Kruse
Rush Truck Center - Austin (Rush Truck Centers of Texas, L.P.)
555 IH 35 South Ste. 200
New Braunfels, TX 78130

Welcome to BuyBoard!

Re: Notice of National Purchasing Cooperative Award; Proposal Invitation No. 723-23, Medium and Heavy Duty Trucks, Parts, and Maintenance Repair Service

Congratulations, The National Purchasing Cooperative (National Cooperative) has awarded your company a BuyBoard® contract based on the above-referenced Proposal Invitation. The contract is effective for an initial one-year term of December 1, 2023, through November 30, 2024, and may be subject to two possible one-year renewals. Please refer to the Proposal Invitation for the contract documents, including the National Purchasing Cooperative Vendor Award Agreement and General Terms and Conditions of the Contract.

To review the items your company has been awarded, please review Proposal Tabulation No. 723-23 at www.buyboard.com/vendor. Only items marked as awarded to your company are included in this contract award, and only those awarded items may be sold through the BuyBoard contract. All sales must comply with the contract terms and must be at or below the awarded pricing as set forth in the General Terms and Conditions.

The contract will be posted on the BuyBoard website as an online electronic catalog(s). **You are reminded that, in accordance with the General Terms and Conditions, all purchase orders from National Cooperative members must be processed through the BuyBoard.** Except as expressly authorized in writing by the Cooperative's administrator, you are not authorized to process a purchase order received directly from a National Cooperative member that has not been processed through the BuyBoard or provided to the Cooperative. If you receive a purchase order directly from a National Cooperative member that you have reason to believe has not been received by the National Cooperative or processed through the BuyBoard, you must promptly forward a copy of the purchase order by e-mail to info@buyboard.com

A list of National Cooperative members is available on the buyboard.com website. Once the contract is active, the BuyBoard vendor relations staff will be contacting you to assist with resources available and provide any support you may need as an awarded BuyBoard vendor.

On behalf of the National Cooperative, we are looking forward to your participation in the program. If you have any questions, feel free to contact me at 800-695-2919.

Sincerely,

Ava Benford, Cooperative Procurement Manager
Texas Association of School Boards, Inc.,
Procurement Administrator for the National Purchasing Cooperative

v.02.01.2021

The Local Government Purchasing Cooperative

For the Period 12/1/2023 to 11/30/2024

Final Catalog Award Report for Medium and Heavy-Duty Trucks, Parts, and Maintenance
Repair Service No. 723-23

200. Base Model Price for Peterbilt Model 589

Vendor Name	Vendor Brand and Model Number	Bid Price	Award
Rush Truck Centers of Texas, L.P.	Peterbilt 589	\$136,418.00	Yes

201. Base Model Price for Peterbilt Model 548

Vendor Name	Vendor Brand and Model Number	Bid Price	Award
Rush Truck Centers of Texas, L.P.	Peterbilt 548	\$84,760.00	Yes

202. Base Model Price for Peterbilt Model 567

Vendor Name	Vendor Brand and Model Number	Bid Price	Award
Rush Truck Centers of Texas, L.P.	Peterbilt 567	\$123,327.00	Yes

203. Base Model Price for Peterbilt Model 537

Vendor Name	Vendor Brand and Model Number	Bid Price	Award
Rush Truck Centers of Texas, L.P.	Peterbilt 537	\$74,416.00	Yes

204. Base Model Price for Peterbilt Model 536

Vendor Name	Vendor Brand and Model Number	Bid Price	Award
Rush Truck Centers of Texas, L.P.	Peterbilt 536	\$74,765.00	Yes

205. Base Model Price for Peterbilt Model 535

Vendor Name	Vendor Brand and Model Number	Bid Price	Award
Rush Truck Centers of Texas, L.P.	Peterbilt 535	\$73,625.00	Yes



BuyBoard Current Vendors - Texas

Vendor	Address Line 1	City	State	ZIP	Effective	Expiration	Contract
RS Commercial Construction, LLC(E) (I)(T)	17250 Dallas Parkway	Dallas	TX	75248	4/1/2024	3/31/2029	Job Order Contracting (RSMMeans) 728-24
RTC Inc(M)(E)(I)(T)	300 E Sunset Rd	El Paso	TX	79922	4/1/2023	3/31/2026	Radio Communications and Video Recording Products and Services 696-23
Rubber Flooring Systems dba RFS Sports(E)(I)(T)	375 COLUMBIA MEMORIAL PKWY	KEMAH	TX	77565	6/1/2024	5/31/2027	Indoor and Outdoor Sports Surfaces, Repair and Renovation and Gym Floor Refinishing 737-24
Rubber Flooring Systems dba RFS Sports(E)(I)(T)	375 COLUMBIA MEMORIAL PKWY	KEMAH	TX	77565	4/1/2025	3/31/2028	Athletic & Physical Education Supplies & Equipment 766-25
Rudy Rodriguez dba 421 Productions (E)(I)(T)	1944 E. Polk St.	Brownsville	TX	78520	12/1/2024	11/30/2027	Stage and Theater Curtains, Lighting, Sound Systems, and Supplies 752-24
Rules of Engagement Tactical, LLC (E)(I)(T)	710 E. Park Blvd, Ste 206	Plano	TX	75074	4/1/2023	3/31/2026	Public Safety and Firehouse Supplies and Equipment 698-23
Rush Truck Centers of Texas LP /dba/ Rush Bus Centers(E)(I)(T)	16345 IH-35 North	Selma	TX	78154	12/1/2023	11/30/2026	School Buses, Options and Parts 722-23
Rush Truck Centers of Texas, L.P.(E)(I)(T)	555 IH 35 South, Suite 500	New Braunfels	TX	78130	12/1/2023	11/30/2026	Medium and Heavy-Duty Trucks, Parts, and Maintenance Repair Services 723-23
Rush Truck Centers of Texas, L.P.(E)(I)(T)	555 IH 35 South, Suite 500	New Braunfels	TX	78130	12/1/2023	11/30/2026	Vehicles, Police Motorcycles, Parts, and Maintenance Repair Services 724-23
Rushing2Winders LLC dba Winders Sales & Services(M)(E)(I)(T)	2910 S.E. Stallings Dr.	Nacogdoches	TX	75961	10/1/2024	9/30/2027	Custodial Supplies and Equipment 747-24
Ryan Sanders Sports Services, LLC /dba/ RS3 Turf(E)(I)(T)	3400 E. Palm Valley Blvd.	Round Rock	TX	78665	6/1/2024	5/31/2027	Indoor and Outdoor Sports Surfaces, Repair and Renovation and Gym Floor Refinishing 737-24
Rydin Decal(E)(I)(T)	700 Phoenix Lake Avenue	Steamwood	IL	60107	12/1/2023	11/30/2026	Copy-Print and Document Management Services 716-23
S & S HVAC Equipment(M)(E)(I)(T)	18085 West Little York	Katy	TX	77449	12/1/2023	11/30/2026	HVAC Equipment, Supplies, and Installation of HVAC Equipment 720-23
S & S Worldwide Inc(E)(I)(T)	75 MILL ST	Colchester	CT	06415	11/1/2024	10/31/2027	Instructional Materials (Non-Adopted) for PK-12, Special Education, & Career and Technology 748-24
S & S Worldwide Inc(E)(I)(T)	75 MILL ST	Colchester	CT	06415	11/1/2024	10/31/2027	Classroom & Teaching Aids, Supplies, & Equipment 750-24
S & S Worldwide Inc(E)(I)(T)	75 MILL ST	Colchester	CT	06415	4/1/2025	3/31/2028	Athletic & Physical Education Supplies & Equipment 766-25

(M) - MWBE (E) - EDGAR Received (D) - Designated Dealer (I) - No Israel Boycott (T) - No Foreign Terrorist Orgs

From: [VALDEZ, MARTIN J.](#)
To: [JARAMILLO, DAVID M.](#)
Subject: RE: Fleet Approvals New Vehicle
Date: Thursday, September 18, 2025 10:37:00 AM

Thanks David.

From: JARAMILLO, DAVID M. <dmjaramillo@santafenm.gov>
Sent: Thursday, September 18, 2025 9:55 AM
To: VALDEZ, MARTIN J. <mjvaldez@santafenm.gov>
Subject: Fleet Approvals New Vehicle

To whom it may concern,

I am writing to express that in the case of **ESD, Fire, Transit, Airport, Complete streets 1 ton and above**, I'm not required to review any of their purchases. This is because I don't over see their fleet or manage those assets.

Please reach out if you have any questions.

David Jaramillo

Fleet section manager

(505)4704682

(505)9552351

Signature: *Martin J Valdez*

Email: mjvaldez@santafenm.gov

Signature: 

Email: jdroach@santafenm.gov

Signature: DEBORA TRUJILLO
DEBORA TRUJILLO (Jan 6, 2026 14:55:43 MST)

Email: dctrujillo@santafenm.gov











GB-550-Rush Truck Centers of New Mexico, Inc.

Final Audit Report

2026-01-09

Created:	2026-01-07
By:	ALYSSA PEREZ (aeperez@santafenm.gov)
Status:	Signed
Transaction ID:	CBJCHBCAABAAGQR7T7kaMVDtPeTpBrKL2Rvkz2T5_C-J

"GB-550-Rush Truck Centers of New Mexico, Inc." History

-  Document created by ALYSSA PEREZ (aeperez@santafenm.gov)
2026-01-07 - 5:43:16 PM GMT- IP address: 63.232.20.2
-  Document emailed to ALYSSA PEREZ (aeperez@santafenm.gov) for filling
2026-01-07 - 5:44:30 PM GMT
-  Form filled by ALYSSA PEREZ (aeperez@santafenm.gov)
Form filling Date: 2026-01-07 - 5:44:56 PM GMT - Time Source: server- IP address: 63.232.20.2
-  Document emailed to ajhopkins@santafenm.gov ajhopkins@santafenm.gov (ajhopkins@santafenm.gov) for signature
2026-01-07 - 5:44:58 PM GMT
-  Email sent to financecommitteemeeting@santafenm.gov bounced and could not be delivered
2026-01-07 - 5:45:05 PM GMT
-  Email sent to governingbody@santafenm.gov bounced and could not be delivered
2026-01-07 - 5:45:15 PM GMT
-  Email viewed by ajhopkins@santafenm.gov ajhopkins@santafenm.gov (ajhopkins@santafenm.gov)
2026-01-08 - 5:20:55 PM GMT- IP address: 104.47.65.254
-  Document e-signed by ajhopkins@santafenm.gov ajhopkins@santafenm.gov (ajhopkins@santafenm.gov)
Signature Date: 2026-01-08 - 5:22:21 PM GMT - Time Source: server- IP address: 63.232.20.2
-  Document sent to JoAnn Lovato (jdlovato@santafenm.gov) and Travis Dutton-Leyda (tkduttonleyda@santafenm.gov) for signature. One of them to sign
2026-01-08 - 5:22:23 PM GMT
-  Email sent to governingbody@santafenm.gov bounced and could not be delivered
2026-01-08 - 5:22:35 PM GMT

 Email sent to financecommitteemeeting@santafenm.gov bounced and could not be delivered

2026-01-08 - 5:22:40 PM GMT

 Email viewed by JoAnn Lovato (jdlovato@santafenm.gov)

2026-01-08 - 5:47:26 PM GMT- IP address: 63.232.20.2

 Email viewed by Travis Dutton-Leyda (tkduttonleyda@santafenm.gov)

2026-01-08 - 6:19:25 PM GMT- IP address: 98.97.114.141

 Document e-signed by Travis Dutton-Leyda (tkduttonleyda@santafenm.gov)

Signature Date: 2026-01-09 - 11:09:54 PM GMT - Time Source: server- IP address: 63.232.20.2

 Agreement completed.

2026-01-09 - 11:09:54 PM GMT

Date: January 16, 2025

To: Governing Body

Via: 
JOHN BURNEY (Jan 23, 2026 07:10:34 MST)
 Sam Burnett, Interim Public Works Department Director
 Melissa McDonald, Parks and Open Space Division Director *M Mc*

From: Phillip Lujan, MRC Business Manager 

ACTION: Request for Approval of a Budget Adjustment Resolution (BAR) to Transfer \$1,060,091 from Available Municipal Recreation Complex (MRC) Cash Balance to the Lodgers' Tax Fund to Reconcile Costs Associated with the Startup of the Golf Course Operating Agreement in FY24.

BACKGROUND AND SUMMARY: In FY24, the City initiated a new operating agreement for the Marty Sanchez Golf Course. As is typical for agreements implemented late in a fiscal year, certain startup costs and revenue timing required reconciliation across multiple funding sources.

Following coordination with Budget and Tourism, Parks completed an accounting of expenses associated with the initial implementation period, including Lodgers' Tax participation. During the transition, additional funding was advanced to support startup operations. Upon reconciliation it was determined that a portion of those funds should be returned to Tourism to align expenditures with funding intent.

The MRC Fund maintains sufficient available cash balance to accommodate this transfer without a material impact to ongoing operations or service levels, absent any unforeseen circumstance. This proposed Budget Adjustment Resolution resolves the FY24 reconciliation and closes out the interdepartmental collaborative funding effort associated with the startup phase of the agreement. FY25-related funding alignment has already been successfully implemented.

City of Santa Fe / Troon FY24 Financial Summary				
FY24	Expenses	\$ 1,352,000.00	FY24 Totals (REV - EXP)	\$ (541,909.43)
	Revenue	\$ 810,090.57		
	Transfer In Amount	\$ 1,602,000.00	Transfer Out Amount (Difference)	\$ 1,060,090.57
Transfer from 5300271.750213 to 213001.650530				

FUNDING SOURCE: Fund Transfer from MRC to Tourism

Fund Name/Number: MUNRECCMP / 530

Munis Org Name/Number: MRC OpsAdm / 5300271

Munis Object Name/Number: OXfrOut213 / 750213

Fund Name/Number: LODTAXFND / 213

Munis Org Name/Number: NonDept LT / 2130001

Munis Object Name/Number: OxfrIn530 / 650530

ATTACHMENTS:

BAR

Date: January 28, 2026

To: Governing Body

From: Carly Venditti, Metropolitan Redevelopment Agency, Deputy Director

Via: Brian Moya, Interim City Manager
Andrea Phillips, Deputy City Manager

Subject: Midtown Infrastructure Design, Owner's Representative

Vendor Name: WSP USA, Inc.

Vendor Number: 2960

ACTION:

Request for Approval of Amendment No. 2 to Professional Services Contract Item 24-0112 with WSP USA, Inc. for Owner's Representative Project Manager Services to Support Redevelopment at Midtown to Increase the Amount of Compensation by \$1,173,861 Including NMGRT for a Total Compensation of \$5,083,861 with a Term Ending October 5, 2026. (Carly Venditti, Metropolitan Redevelopment Agency Deputy Director, cavenditti@santafenm.gov)

CONTRACT NUMBER:

The Munis Contract Number is 3204300.

BACKGROUND AND SUMMARY:

Pursuant to Resolution #2022-12, the Midtown Master Plan was adopted by the Governing Body on November 30, 2022 (Resolution #2022-68) followed by the Community Development Plan on January 25, 2023 (Resolution #2023-5). Together, these redevelopment plans outlined the path to an equitable redevelopment, in the heart of Santa Fe for the Santa Fe community. As one of the first steps, the City of Santa Fe created the Metropolitan Redevelopment Agency to collaborate with existing City departments on the redevelopment effort including Public Works and Land Use. The creation of the Metropolitan Redevelopment Commission allows appointed volunteers who are experts in community planning, commercial real estate development, affordable housing, and financial services to represent the citizens of Santa Fe.

The Metropolitan Redevelopment Agency and Commission continue to support ongoing development throughout the Midtown Site since the approval of the Aspect Media Village Development Disposition Agreement (Resolution 2024-12), a direct disposition of property window April to June 2025, resulting in five development proposals and two Exclusive Negotiation Agreements, and a Master Plan amendment approval all through unanimous support. Facilitating the full design of Midtown Infrastructure will enable the continuation of the project and facilitate connection to existing development entities including Aspect Media Village and the Midtown Arts and Design Alliance (MADA).

Infrastructure design began in February 2024, founded on the values of the Midtown Redevelopment Plans to achieve an equitable development, with innovative stormwater infrastructure, and intent to facilitate high levels of mobility for all users. WSP USA, Inc. (WSP) continues to collaborate with the engineering company, Wilson & Company to design infrastructure so it may lay the groundwork for new community-centered development.

WSP has proven its capability in delivering the 60% infrastructure design and, through this proposed contract amendment, will advance the full 100% design for the Midtown Site. The amendment also includes support for high-level negotiations and development agreements, as well as program management services such as progress reporting, workshops, and contractor coordination to assist the city in preparing for infrastructure procurement.

Project funding has been facilitated through a variety of capital outlay funding expenditures MTC245250D-EngSvs Capital Appropriations to support infrastructure (awarded in 2021) and MTC2452504-Design to support Midtown infrastructure design (awarded in 2023). If approved, infrastructure design is expected to be complete by the end of Spring 2026 and launch for procurement in the Summer of 2026. Dependent on funding, WSP will assist in the packaging and promotion of final infrastructure plans for development.

ATTACHMENTS:

Amendment No. 2

Amendment No. 2 Proposal(s)

CES Agreement No. 2023-01-C211-ALL

Certificate of Insurance

Amendment No. 1 Packet (Item No. 24-0311)

Professional Services Contract Packet (Item No. 24-0112)

PRIOR APPROVALS AND SUPPORTING INFORMATION:

FUNDING SOURCE:

Fund Name/Number: MIDTOWNPRO/525
Munis Org Name/Number: MTC CapPrj/5250610
Munis Object Name/Number: WIP Design/572960
Project Ledger ID: MTC245250D

Budget Officer/Designee: Andy Hopkins Date: 01/29/2026
Budget Officer Comment/Exceptions: _____

PROCUREMENT METHOD:

The procurement method is the Cooperative Education Services Price Agreement (CES) Contract No. 2023-01-C211-ALL which expires on October 5, 2026.

Chief Procurement Officer (CPO)/Designee: _____ Date: 01/29/2026
CPO Comment/Exceptions: _____

ASSOCIATED APPROVALS:

IT Components included? Yes | No

Approval: _____ Title: _____ Date: _____
Comment/Exceptions: _____

Treasury/Point of Sale Components included? Yes | No

Approval: _____ Title: _____ Date: _____
Comment/Exceptions: _____

Vehicles included? Yes | No

Approval: _____ Title: _____ Date: _____
Comment/Exceptions: _____

Construction to City Facilities, Furniture, and/or Fixtures, included? Yes | No

Approval: _____ Title: _____ Date: _____
Comment/Exceptions: _____

Is this an externally funded purchase? Yes | No

If yes, what is the issuing agency: _____
Approval: _____ Title: _____ Date: _____
Comment/Exceptions: _____

Capital Asset or Project? Yes | No

Project Ledger Number _____
Approval: _____ Title: _____ Date: _____
Comment/Exceptions: _____

Item No.: _____
Munis Contract No.: 3204300
Original Contract Item No.: 24-0112
CES Contract No.: 2023-01-C211-ALL

CITY OF SANTA FE, METROPOLITAN REDEVELOPMENT AGENCY
AMENDMENT No. 02 TO
PROFESSIONAL SERVICES CONTRACT
ITEM No. 24-0112

Midtown Improvements - Design

This AMENDMENT No. 02 (the “Amendment”) amends the CITY OF SANTA FE Professional Services CONTRACT, dated February 20, 2024 (the “Contract”), between the City of Santa Fe (the “City”) and WSP USA Inc. (the "Contractor"). The date of this Amendment shall be the date when it is executed by the City and the Contractor whichever occurs last.

RECITALS:

A. Under the terms of the Contract, Contractor has agreed to provide the City of Santa Fe with Owner’s Representative Services to implement the Infrastructure of the Midtown Master Plan and Community Development Plan.

B. Pursuant to Article 15 of the Contract, and for good and valuable consideration, the receipt and sufficiency of which are acknowledged by the parties, the City and the Contractor agree as follows:

1. COMPENSATION

Article 4, paragraph A of the Contract is amended to increase the amount of compensation by a total of \$1,173,860.34 (including NMGRT of 8.1875%) so that Article 4, paragraph A reads in its entirety as follows:

A. The City shall pay to the Contractor in full payment for services satisfactorily performed

based upon milestones, such compensation not to exceed one million, one hundred seventy-three thousand, eight hundred sixty dollars and thirty-four cents (\$1,173,860.34) including gross receipt tax of 8.1875%. **The total amount payable to the Contractor under this Agreement, including gross receipts tax and expenses, shall not exceed five million, eighty-three thousand, eight hundred sixty dollars and thirty-four cents (\$5,083,860.34). This amount is a maximum and not a guarantee that the work assigned to be performed by Contractor under this Contract shall equal the amount stated herein. The parties do not intend for the Contractor to continue to provide services without compensation when the total compensation amount is reached. Contractor is responsible for notifying the City when the services provided under this Contract reach the total compensation amount. In no event will the Contractor be paid for services provided in excess of the total compensation amount without this Contract being amended in writing prior to those services in excess of the total compensation amount being provided.**

2. CONTRACT IN FULL FORCE:

Except as specifically provided in this Amendment, the Contract remains and shall remain in full force and effect, in accordance with its terms.

[REMAINDER OF PAGE INTENTIONALLY LEFT BLANK]

[SIGNATURE PAGE TO FOLLOW]

IN WITNESS WHEREOF, the parties have executed this Amendment No. 2 to the Contract as of the dates set forth below.

CITY OF SANTA FE:

MICHAEL GARCIA, MAYOR

DATE: _____

CONTRACTOR:

WSP USA, Inc.

Daniel Sims

Daniel Sims (Jan 21, 2026 13:16:56 MST)

DANIEL SIMS, SENIOR VICE PRESIDENT

DATE: Jan 21, 2026

NMBTIN: _____

ATTEST:

CITY CLERK

CITY ATTORNEY'S OFFICE:

Kevin L. Nault

Kevin L. Nault (Jan 21, 2026 14:06:57 MST)

KEVIN NAULT, ASSISTANT CITY ATTORNEY

APPROVED FOR FINANCES:

BRIAN MOGA

FINANCE DIRECTOR



September 12, 2025

Dear Mark,

WSP USA, Inc. is pleased to submit this proposal to continue supporting the City's strategic initiative to redevelop the Midtown Campus and specifically, Metropolitan Redevelopment Agency's (MRA) and the City Manager's role in this effort. This scope of work is for the continuation of Owner's Representative services and activities through design completion and the contractor bidding phase and covers the period from September 1, 2025 to October 1, 2026. The infrastructure design is critical for project delivery and will require vigorous oversight as the project schedule is condensed. The accelerated project schedule will require real-time decision making for successful project delivery. Engineering reviews only at milestone submittals will not allow enough time for the design team to react quickly enough to maintain the schedule, so we will implement over the shoulder reviews and strategic design sessions with necessary City agencies. Additionally, we will help to support the City with on-going funding, financing and delivery discussions. Since the City has moved in the direction to make available most or all development parcels, engagement with potential developers via the MRA is expected. Our team will continue to support the MRA in the project development process and provide oversight through design ensuring successful project delivery.

Key Milestones in this Work Plan

- Oversight and coordination of the design and strategy process for Midtown infrastructure, parks, open space and trails
- Midtown infrastructure has transitioned to 100% for the entire site, not just Phase 1 Spine Infrastructure, as a result of discussions with the Mayor, City Manager and MRA's marketing strategy
- Support MRA's coordination efforts with Public Works and other City infrastructure agencies
- Prepare an O&M cost summary for the infrastructure based on the 60% and 90% design packages
- Review Draft Geotech Report(s) and Sitewide Survey
- Coordination of design with Subdivision/Platting process and any potential Master Plan Amendments
- Support the City with ongoing coordination with PNM and other key utility providers
- Critical path schedule updates and tracking (design, tenant relocations, demolition, etc.)





- High level DDA support for infrastructure related items (similar to Film Studio DDA) for MADA and other potential ENAs or DDAs during the design period.
- Support the City with on-going funding, financing and delivery discussions

Key Milestones Accomplished in Last Work Plan

- ✓ Program management and coordination with City team on key infrastructure coordination items and strategy (i.e., Beyond 30% infrastructure design, ENN meeting, PNM coordination, GSD discussions)
- ✓ Oversight and coordination of infrastructure design
- ✓ Critical path schedule updates and tracking
- ✓ Support for MADA infrastructure discussions

OWNERS REP BUDGET SUMMARY

Past Work Plan (October 22, 2024 to August 31, 2025)

	<i>PO Replacement Budget</i>	<i>Invoiced (w/ GRT) as of 8/31/25</i>	<i>Remaining Budget (w/ GRT) as of 8/31/25</i>
<i>PO 22502532 - Project Management</i>	\$195,521	\$161,360	\$34,161
<i>PO 22502529 – Spine Infrastructure</i>	\$199,173	\$77,742	\$121,431

Current unpaid invoices for July and August 2025 total to the following:

Program Management: \$20,400.35
 Spine Infrastructure: \$4,671.23

Highlights of any Staff or Approach Changes

- 100% design of sitewide infrastructure, not just Spine Infrastructure. Our team will have SMEs for bi-weekly over-the-shoulder design reviews to streamline decision making and advise MRA and the City Manager on best approaches. WSP will also provide SMEs for major milestone submittals to ensure we bring the right oversight and coordination to the table

Highlights of Innovations to Reduce Costs and Accelerate Schedule

- Coordinate with City on the ITB boilerplate during the 60% and 90% design process to ensure it is ready when design completes.
- Coordinate with Wilson and City on drafting of Contract Book for ITB process during the 60% and 90% process





- Coordinate with State's GSD Office on entitlements for Alumni Drive ROW, Stormwater Pond, and Tract O ROW design
- Coordinate quarterly discussions with Philip Geuse for Film Studio and Arthouse projects with City's design efforts as required in the DDA
- Continual coordination with Wilson and utilities (PNM, telco/fiber, etc.) to include their needs in design
- Closely document and distribute design decisions to reduce rework and drive project delivery
- At 60% design review
 - Identify VE ideas/solutions to reduce construction schedule and costs
 - Clearly define construction phasing/sequencing based on infrastructure continuity
 - Hold a contractor information session on Midtown and anticipated schedule to get this into their project planning cycle



Proposed Additional Budget for September 1, 2025 to October 1, 2026

	Total with Reimbursable Expenses	Estimated NM GRT	Total with GRT
<i>PO 22502532 - Project Management</i>	\$561,174.00	\$45,946.12	\$607,120.12
<i>PO 22502529 – Infrastructure Oversight</i>	\$523,850.00	\$42,890.22	\$566,740.22
<i>Total</i>	<i>\$1,085,024.00</i>	<i>\$88,836.34</i>	<i>\$1,173,860.34</i>

See WSP Staff, Hours and Budget summary page

PO 22502532 - PROJECT MANAGEMENT BREAKDOWN

	Total with Reimbursable Expenses	Estimated NM GRT	Total with GRT
<i>Project Management</i>	\$487,167.00	\$39,886.80	\$527,053.80
<i>Critical Path Schedule</i>	\$27,112.00	\$2,219.80	\$29,331.80
<i>Document Management</i>	\$12,020.00	\$984.14	\$13,004.14
<i>DDA Support</i>	\$34,875.00	\$2,855.39	\$37,730.39
<i>Total</i>	<i>\$561,174.00</i>	<i>\$45,946.12</i>	<i>\$607,120.12</i>

See WSP Staff, Hours and Budget summary page



WSP STAFF, HOURS & BUDGET

PROGRAM MANAGEMENT STAFF & HOURS

WSP Staff	Role	Monthly Hours	Total Hours
Aron Kirsch	PM/Executive Leadership	64*	960
Mousa Al-Shanti	Critical Path Schedule	10	110
Juvy Teves	Progress Reports/Accounting	4	240
Tracy Bond	Sharepoint Site Management	4	240
Kate Iverson	DDA Review Support	15	90

Note: * Aron's hours are equivalent to 16 hours / 2 days per week on average

INFRASTRUCTURE DESIGN OVERSIGHT STAFF & HOURS

WSP Staff	Role	Monthly Hours	Total Hours
Danny Sims	PM	30	450
Tate Toledo	DPM	40	440
Mark Montgomery	Electrical Lead	N/A	250
Burke Lokey	Stormwater, Wet Utilities	15	180
Sugam Tandukar	Water / Wastewater Engineer	15	150
Dustin Davidson	Stormwater	N/A	100
Risa Lujan	Lighting / Signing and Striping	N/A	100
Jonathan Wasson	Constructability	20	200
Ernest Archuleta	Constructability	N/A	100
Jacobo Pacheco	Plat/Survey	N/A	60
Julia Smith	Geotech	N/A	60
Christian Zimmer	O&M Analysis	15	90

CONTRACTOR PROCUREMENT PHASE SERVICES

WSP Staff	Role	Monthly Hours	Total Hours
Danny Sims	Contractor Procurement Support	N/A	10
Tate Toledo	Contractor Procurement Support	N/A	30
Burke Lokey	Contractor Procurement Support	N/A	10
Jonathan Wasson	Contractor Procurement Support	N/A	40
Ernest Archuleta	Contractor Procurement Support	N/A	10



PROGRAM MANAGEMENT

- **Project Management / Executive Leadership** (Aron Kirsch)
 - Provide MRA with support to progress the infrastructure steps and coordination
 - Participate in Internal Stakeholder (City's Midtown Team, Mayor, City Manager and GB briefings) meetings. Assumption is 2 meetings during the the design phase. GB allocation of 4 hours for preparation and 4 hours delivery, if required.
 - Review/Advise on any proposed revisions to the baseline infrastructure plan and schedule
 - Coordinate with WSP Infrastructure PM, scheduler, and monthly progress reports and invoicing.
 - Advise on strategy to position MRA for successful delivery; may include occasional workshops
 - Agenda distribution prior to meetings
 - Coordinate with Wilson on the distribution of meeting notes and action items within three days after meetings
 - Proactively exceed expectations, add value, address issues at lowest level possible and provide recommendations
 - Minimize workload on City staff
 - Coordinate with GSD and other agencies on behalf of the City to drive progress and solutions for the infrastructure design and implementation
 - Coordinate with MRA and Developers, as needed, on proposed development schedules and infrastructure requirements
 - Coordinate with design team on industry outreach events, contractor discussions, and GSI manufacturer discussions, as needed

- **Critical Path Schedule** (Mousa Al-Shanti)
 - Ongoing updates, as needed
 - Breakout or fine-tuned schedule(s) for design, utilities relocations, demolition, and building stabilization, as needed

- **DDA Review Support** (Kate Iverson)
 - High-level review to identify missing items/scope that could impact infrastructure delivery. Similar to the Film Studio DDA review. Assumes equivalent of 6 months of support.
 - Review terms for impact to City's infrastructure
 - Meeting(s) with MRA and with internal City team (i.e. Legal, PWD, Land Use), as needed.





- If the support is more than high level and requires regular weekly participation in internal or external meetings and negotiations then we will advise MRA and discuss added fee for these services.
- Funding & Phasing Plan / Financing Support with 3rd Party Partners
 - No specific analysis or team required at this time. If required, will agree on an Add Service at such time.

INFRASTRUCTURE DESIGN MANAGEMENT

- **PM: Daniel Sims**
- DPM: Tate Toledo
- Civil: Tate Toledo, Andrew Sutliff, Daniel Sims
- Wet Utilities: Sugam Tandukar
- Drainage: Burke Lokey, Dustin Davidson
- Constructability: Jonathan Wasson, Ernest Archuleta
- Lighting, Signing & Striping: Risa Lujan
- Plat/Survey: Jacobo Pacheco
- Dry Utilities: Mark Montgomery
- Geotech: Julia Smith
- O&M Analysis: Christian Zimmer

Design Phase (July 1, 2025 to May 31, 2026)

- Attend/participate in public meetings that the Design Team will hold/manage; Anticipate two (2) of these meetings in this phase at 60% and 90% or 100% design. Design team is leading the public meeting efforts.
- Review/Advise on design work, critical decisions and milestones, scope, budget, O&M, invoicing, and schedule
- Checklist review of 60% and 90% construction plan submittals
- Prepare an O&M cost summary for the infrastructure at 60% and 90% design. Main categories are Facilities (restroom), Rights of way, and Parks (including trails). Interviews with the Division Directors, as well as research on comparables and industry standards.
- Support City's ongoing coordination with PNM for electrical infrastructure (Tim Farrell at PWD) has been leading this effort due to strong working relationship with PNM. WSP will continue to work with Tim, MRA, Wilson and others as necessary to further this coordination.
- Design: Manage the 60%, 90% and 100% design process



- Design Schedule as of September 1, 2025
 - 60% submittal is October 3, 2025
 - 90% submittal is December 19, 2025
 - 100% submittal is February 20, 2026
 - Arroyo Park: 90% is March 27, 2026 and 100% is May 22, 2026

Key Tasks

- WSP will maintain the Baseline Design Schedule with milestones consistent with the critical path schedule. Milestones will include key decision points for MRA and submittal dates for interim and final deliverables with time allotted for reviews. For the duration of this scope, July 1, 2025 through May 31, 2026, it is anticipated that 60%, 90% and 100% design packages will be submitted by the designer.
 - Design team will provide monthly updates to the design schedule, if there are critical changes.
 - WSP will incorporate key design updates and other City program updates to the overall schedule into the Critical Path Schedule.
 - Schedule will follow design schedule provided by WCI
- WSP will coordinate regular weekly progress meetings to track status of design efforts, review design decisions, identify any coordination problems or concerns, and review consultant invoicing.
 - WSP will coordinate design reviews for 60%, 90% and 100% packages with the MRA and City's agency staff
 - Design reviews will be a combination of in-person and Bluebeam sessions – the designer will schedule meetings and upload Bluebeam sessions



- WSP will provide thorough engineering technical reviews for all aspects of proposed infrastructure including standard requirements of roadways, intersections, curb and gutter, sidewalk widths, NMDOT specs for asphalt and base, signage plans, streetlights, photometric analysis, and ADA compliance, quantity takeoffs and constructability of proposed infrastructure.
- WSP staff will provide review for the following:



- Accelerated development of drainage design parameters for Arroyo Park to facilitate coordination with landscape design effort.
 - Engineering reviews for roadway, storm drain, dry and wet utilities and cost estimates for constructability, adherence to design guidelines and governing documents.
 - Adherence to submittal checklist and plan set completeness
 - Storm drain review key focus areas are: 1) establishing the design storm and peak flows for the system, deciding on, 2) providing details for the storm drain outfall and establishing its viability, and 3) analysis of how individual blocks will connect their drainage to the spine infrastructure.
 - Constructability reviews to identify any potential construction issues with proposed infrastructure, particularly proposed GSI infrastructure. WSP staff will coordinate with manufacturers and agencies that have used the proposed products to understand construction methods and lessons learned on previous projects.
 - Review quantity takeoffs to support cost estimate reviews
 - Review cost estimates at 60%, 90% and 100% design. Review will include construction cost assumptions for accuracy using bid data and available unit cost guides.
 - Review survey and plat revisions
 - Prepare an O&M cost estimate summary based on the 60% and 90% design packages, interviews with Division Directors and Wilson, comparables and industry standards.
 - Document design decisions to track through project development and ensure consensus to minimize rework in later phases
 - Develop distribution list and ensure necessary departments and stakeholders are distributed plans and have an opportunity to review
- WSP will advise and coordinate potential construction phasing/sequencing at 60% and 90% design packages based on budget, tenant needs, and infrastructure continuity
 - WSP will review design team invoices for each contract monthly, and recommend full, partial, or no payment based on work completed by the design team for that invoice period. Invoice status including work completed, total billed and paid amounts will be recorded and summarized for MRA staff.

Contractor Procurement Phase (October 2025 to October 2026)

- In coordination with the City Manager and MRA, WSP and Wilson will hold an industry outreach event in October 2025 to brief contractors on the project,



receive any high level input or concerns, and get this project into their work cycles for 2026 and beyond.

- WSP will work with the MRA, the City's Procurement, Legal, Public Works and Parks departments, and the Wilson design team to oversee the preparation of all necessary documentation to support the Contractor procurement process (ITB process).
- Coordinate with City and Wilson on the ITB boilerplate during the 60% and 90% design process to ensure it is ready when design completes
- During the bidding process, our team will always be available to provide assistance whenever necessary, guaranteeing a seamless bidding experience.
- We will manage Wilson's delivery of the final construction documents to the City
- WSP and Wilson will attend the pre-bid meetings, offering support with any addenda necessary due to questions, value engineering (VE) options, or clarifications requested by potential contractors.



CITY'S NEW 100% INFRASTRUCTURE SUMMARY

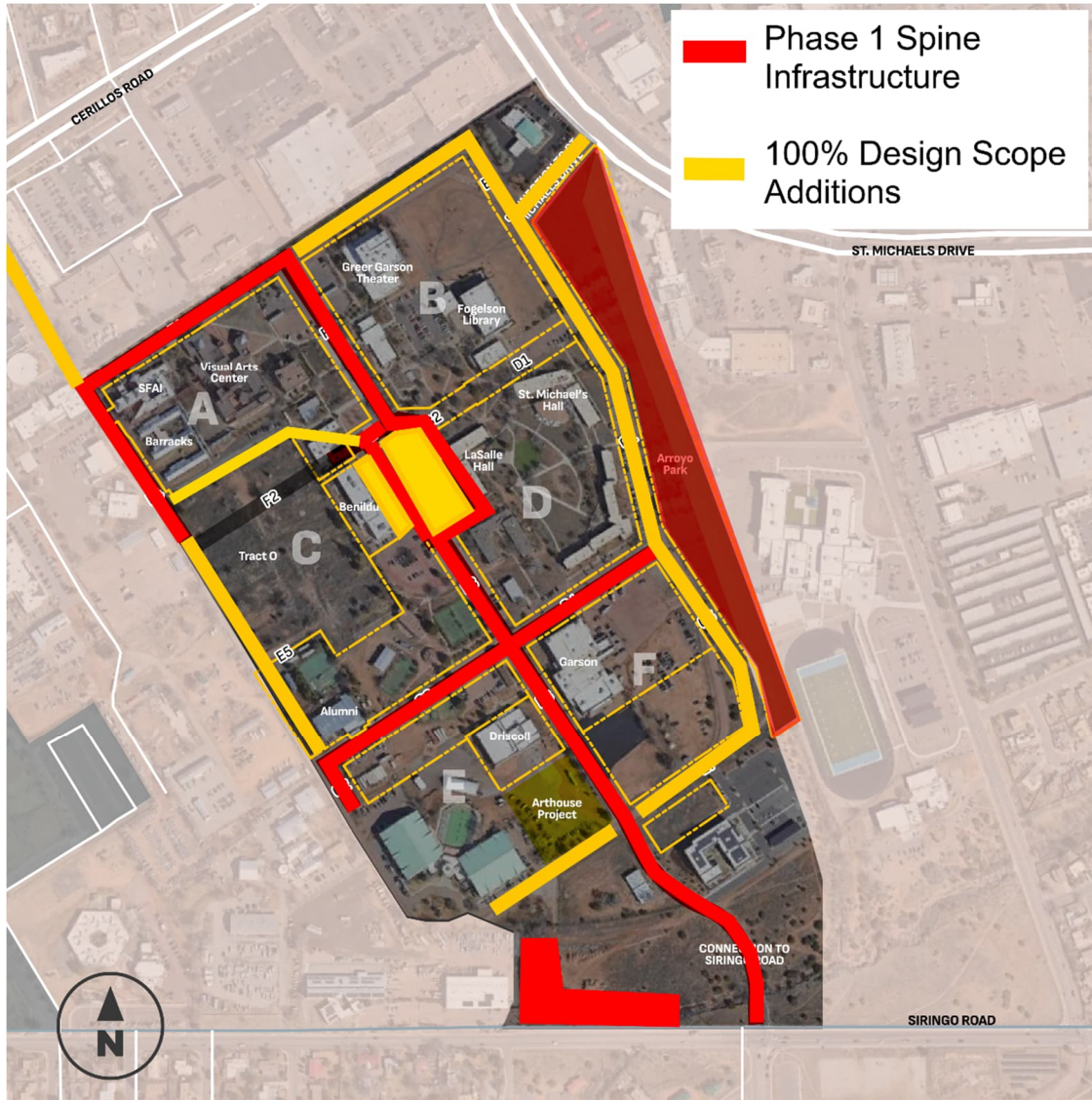

Does NOT include:

- Parking Garage design
- Connection from Midtown to Cerrillos
- St. Michaels intersection design.



CITY'S PRIOR PHASE 1 INFRASTRUCTURE SUMMARY

Phase 1A Design and Activation

- \$8M committed
- Aspect Rehabilitation
- Demo Mouton/Lasalle
- Pavement Rehabilitation
- Early Site Activation
- Design of Infrastructure
- MRA/Tax Increment Plan
- Neighborhood Stabilization Plan

Map labels include: Early Activation Site, Vital Spaces & MRA Office, Road Stabilization, Santa Fe Art Institute, Tract O State Property, Aspect Studios Rehabs, Demolitions, and ArtHouse 129 housing units (not on City Property).

Phase 1B Construction

- 310 housing units (>30% affordable)
- Phase 1 infrastructure package includes:
 - Spine road + utilities
 - Open space + trails
 - Entrance improvements
 - Demolitions
- Midtown Arts and Design Alliance Rehab
- Greer Garson Black Box Rehab
- Rough Estimate: \$30M
- Potential Sources
 - Developer Contributions
 - Federal (EDA)
 - Legislative Capital Appropriations
 - Philanthropic and Grants
 - City of Santa Fe

Map labels include: Affordable Housing Parcel (60 Units), Greer Garson Theater Phase 1, Development Parcel (120 Units), Midtown Art & Design Alliance, Tract O State Property, Activation Areas: Plaza and Bandshell, Open Space and Trails, Demolitions, Spine Road and Utilities, and Aspect Housing 130-150 Units.

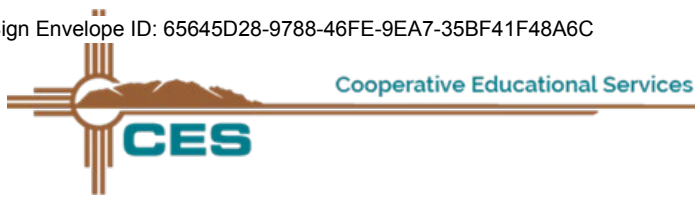

Contract Award Letter

October 5, 2022

Wood Environment & Infrastructure Solutions, Inc.
4221 Balloon Park Road NE
Albuquerque, NM 87109

Re: Contract Award for:

2023-01-C211-ALL Design Professional Services, Category 2 - Lot 1, Engineering and Consulting Services

Dear Procurement Partner,

Cooperative Educational Services (CES) thanks you for responding to our 2023-01 solicitation. The responses have been reviewed and it is our pleasure to inform you that your company has been selected to provide the products and services indicated in your response.

The Contract, in conjunction with the Contract and RFP documents, constitute the Agreement between the parties. Please retain all documents for your records. This Indefinite Delivery and Indefinite Quantity contract, as defined in NMSA 13-1-63; is for Four (4) years beginning October 6, 2022 and expiring October 5, 2026, pursuant to 13-1-150 NMSA.

It is the vendor's responsibility to keep pricing up to date throughout the life of the contract.

Sincerely yours,

Cooperative Educational Services

A handwritten signature in blue ink that reads "David Chavez". The signature is fluid and cursive, with a long, sweeping tail on the letter "y".

David Chavez
Executive Director, Chief Procurement
Officer
Office: 505.344.5470

ACCEPTANCE OF PROPOSAL AND CONTRACT AWARD

CES RFP NUMBER: 2023-01

RFP DESCRIPTION: Design Professional Services Category 2 - Lot 1, Engineering and Consulting Services

CES CONTRACT NUMBER: 2023-01-C211-ALL

CONTRACT

This contract award is being made by Cooperative Educational Services (“CES”), 10601 Research Rd. SE, Albuquerque, New Mexico 87123 effective this October 6, 2022, to Wood Environment & Infrastructure Solutions, Inc., with its principal office located at 4221 Balloon Park Road NE, Albuquerque, NM 87109 pursuant to the above referenced CES conducted Request for Proposal (“RFP”), or Request for Bids (“RFB”) procurement, and Contract Holder accepts the award and enters into this contract pursuant to the following terms and conditions.

RECITALS

Cooperative Educational Services (CES) is a cooperative procurement agency created by a Joint Powers Agreement as authorized by Section 11-1-1, et. seq., N.M.S.A., 1978, and Section 13-1-135 and procures tangible personal property, services, and construction services (“Products, Services and/or Construction Services”) pursuant to the New Mexico Procurement Code for the benefit of its Members and Participating Entities. The Members consist of public educational institutions in New Mexico that are signatories to a Joint Powers Agreement establishing CES as their procurement agency. The Participating Entities are governmental and 501(C) (3) organizations that have entered into Participating Entity Agreements with CES which allow them to take advantage of the procurement efforts of CES.

The undersigned (Contract Holder) has successfully responded to a RFP or RFB published by CES in accordance with the Procurement Code, (13-1-103, 111, 112), and Contract Holder is being awarded this RFP or RFB contract by CES which allows Contract Holder to offer Products, Services and Construction Services in accordance with the terms and conditions set forth herein and in the RFP or RFB documents and this contract award.

CONTRACT TERMS

1. The contract term shall be for Four (4) years from the effective contract award date October 6, 2022 through October 5, 2026. CES reserves the right to renew the Contract through a written amendment signed by all required signatories, but in any case, the Contract shall not exceed the total number of years allowed pursuant to NMSA 1978 13-1-150. CES reserves the right to offer month-to-month extensions if it is determined by CES to be in the best interest of CES Members/Participating Entities.

2. Contract Holder agrees and acknowledges that the contract terms and provisions are those contained in the above referenced RFP or RFB and agrees to furnish all Products, Services and/or Construction Services in compliance with all terms, conditions, specifications of and amendments to this RFP, IFB or RFB. Contract Holder understands that his obligations under this RFP or RFB contract extend to CES Members and Participating Entities who are third party beneficiaries of this RFP or RFB procurement process. The Members/Participating Entities may negotiate with Contract Holder certain additional terms and conditions relating to the scope of services and other performance details. However, the terms and conditions of the RFP or RFB may not be altered or amended except with the approval of CES and in accordance with the State Procurement Code.

3. Contract Holder acknowledges and agrees that CES' purpose and function is to act as a cooperative procurement agent on behalf of its Members and Participating Entities so that they may take advantage of these procurement efforts. CES does not have any subsequent responsibility relating to the quality and fitness of any Products, or the performance of any Services and Construction Services by Contract Holder. Any purchase orders placed by a CES Member or Participating Entity with Contract Holder directly or through CES and any resulting contract between the Contract Holder and a CES Member or Participating Entity do not create any additional obligations on the part of CES.

4. For transactions which involve CES transmitting purchase orders from a CES Member/Participating Entity to Contract Holder, CES volunteers to act as a payment facilitator to make payments to Contract Holder with funds transferred to CES by the CES Member/Participating Entity in accordance with CES Member/Participating Entity's written instructions and to provide an accounting of all monies paid or received by CES pursuant to this Agreement. CES also volunteers to provide informal mediation services between Contract Holder and CES Member/Participating Entity in the event any dispute arises between them.

5. Contract Holder understand and agree that upon CES' receipt of funds from CES Member/Participating Entity, CES has no right or authority to thereafter apply those funds to any purpose other than as instructed by CES Member/Participating Entity. CES shall incur no liability to Contract Holder except for liability arising from CES' own gross negligence or willful misconduct to the extent allowed by New Mexico law. Through this procurement process, Contract Holder is

6. authorized to provide the described Products, Services or Construction Services. CES has no obligation or right to involve itself with the manner or method by which Contract Holder provides these Products, Services or Construction Services.



7. To the extent allowed by New Mexico law, Contract Holder agrees to hold CES harmless from all costs, expenses, attorney fees and judgments based upon claims between a CES Member/Participating Entity and Contract Holder in connection with the specified Products, Services or Construction Services provided by Contract Holder

8. Contract Holder agrees that it will not assert any claim against CES in the event that a dispute arises regarding the alleged failure of Contract Holder or CES Member/Participating Entity to perform as provided for in the RFP or RFB documents, any purchase order or other contract between Contract Holder and a CES Member/Participating Entity. This does not include claims against CES based upon the alleged gross negligence or intentional acts of CES.

9. Any liability incurred in connection with this Agreement shall be subject to the immunities and limitations of the New Mexico Tort Claims Act, §§ 41-4-1 et seq, NMSA 1978, as amended.

9. The Recitals are incorporated herein as contract terms.

Agreed effective the above date:

Cooperative Educational Services

Wood Environment & Infrastructure Solutions, Inc.

David Chavez
Printed Name

Dan A. Kwiecinski
Printed Name

By: David Chavez

By: DocuSigned by: Dan A. Kwiecinski

Title: Executive Director

Title: NM Operations Manager

Date: 10/6/2022

Date: 10/26/2022

**ATTACHMENT A
TO CONTRACT 2023-01-C211-ALL
ACCEPTANCE OF PROPOSAL
AND CONTRACT AWARD**

**GENERAL SCOPE OF WORK AND SPECIFICATIONS
CES RFP 2023-01 Design Professional Services
Category 2 - Lot 1, Engineering and Consulting Services**

GENERAL

This contract shall comply with the Procurement Code, 13-1-154.1 NMSA 1978 thresholds for on-call design professional services as follows:

Design fees for a single project shall not exceed Six Hundred Fifty Thousand Dollars (\$650,000) and the contract term shall not exceed four (4) years or Seven Million Five Hundred Thousand (\$7,500,000) whichever occurs first.

1. ENGINEERING BASIC SERVICES

Professional engineers may engage in the practice of engineering and perform engineering work pursuant to the Engineering and Surveying Practice Act as individuals, partners or through joint stock associations or corporations. In the case of an individual, the individual shall be a professional engineer pursuant to the Engineering and Surveying Practice Act. All plans, designs, drawings, specifications, or reports that are involved in such practice, issued by or for the practice, shall bear the seal and signature of a professional engineer in responsible charge of and directly responsible for the work issued. In the case of practice through partnership, at least one of the partners shall be a professional engineer pursuant to the Engineering and Surveying Practice Act, and all plans, designs, drawings, specifications or reports that are involved in such practice, issued by or for the partnership, shall bear the seal and signature of the professional engineer in responsible charge of and directly responsible for such work when issued. In the case of practice through joint stock association or corporation, services or work involving the practice of engineering may be offered through that joint stock association or corporation; provided the person in responsible charge of the activities of the joint stock association or corporation that constitute engineering practice is a professional engineer who has authority to bind such joint stock association or corporation by contract; and further provided that all plans, designs, drawings, specifications or reports that are involved in engineering practice, issued by or for such joint stock association or corporation, bear the seal and signature of a professional engineer in responsible charge of and directly responsible for the work when issued.

An individual, firm, partnership, corporation, or joint stock association may not use or assume a name involving the terms "engineer", "professional engineer", "engineering", "registered" or "licensed" engineer or any modification or derivative of such terms unless that individual, firm, partnership, corporation or joint stock association is qualified to practice engineering in accordance with the requirements in this section.

The purpose and scope of work for Category 2 is to acquire a full-service engineering firm(s) or surveying firms to provide services that *may* include the professional licensed disciplines in in Category 1.

2. ENGINEERING SERVICES CLASSIFICATIONS

- a. consultation, research, investigations, and reports
- b. Design services for construction projects
- c. Engineering support services

3. PROJECT PHASES

Each individual project's scope of work performed will be subject to the individual CES Member or Participating Entity engaging, assessing, evaluating, selecting, and negotiating with the Offeror that possesses the qualifications, background, experience, attributes and resources that best fit their project's goals, objectives and outcomes, and to assist them in developing, implementing, executing, conducting and completing the identified project in the most cost effective and timely manner. The project phases may include, but are not limited to:

1. Programming phase;
2. Conceptual design and alignment studies;
3. Schematic design phase;
4. Design development phase;
5. Construction documents phase;
6. Procurement and/or bidding phase;
7. Construction phase;
8. Project acceptance and close-out;
9. Project 11-month warranty phase
10. CES Member/Participating Entity retainage of records

4. DESIGN ACTIVITIES

The tasks and activities to be performed may relate to and include, but are not limited to new infrastructure, facility and building construction.

5. Hourly Rate Schedule and Reimbursable Fees shall be submitted after Final Award Notice for the Contract File:

The Offeror will furnish its proposed hourly rate schedule and Reimbursable Fees schedule that will become part of the Offeror's procurement file. The Hourly Rate Schedule must clearly state and identify any/all services and related services proposed in response to this solicitation with their associated costs, whether provided by the Offeror. The Offeror will maintain, keep current and provide copies of the approved hourly rate schedule to CES Agencies for audit purposes when preparing quotes. The Hourly Rate Schedule may be modified at contract renewal.

6. Quote/Proposal for the Work for CES Member/Participating Entity: When preparing a quote/proposal under a CES-awarded contract, the Offeror must clearly identify and break out services, deliverables, materials, and reimbursable expenses into individual line items as they appear on the Offeror's awarded price schedule or pricing methodology. Stated prices must include the CES one percent (1.25 %) administrative fee.

End of Category 2 / Lot 1 Scope of Work

ATTACHMENT B
ACCEPTANCE OF PROPOSAL, OFFER,
AND CONTRACT AWARD
Design Professional Services
Category 2 - Lot 1, Engineering and Consulting Services

PRICING

All pricing including updates/changes must be uploaded through the vendor portal in the eProcurement System for review and approval by CES.

- A. **Price List/Pricing:** The Offeror will upload through the vendor portal electronic copies of or provide electronic access to the approved current price list(s) for products and services offered under this solicitation (RFP) upon execution of this contract. The Offeror must keep current all pricing for any contract issued as a result of this solicitation. Should the Offeror fail to update pricing with CES, the Offeror shall honor their pricing on file with CES at the time of their quote submittal to the CES Member/Participating Entity. Discounts off the current price list are permitted and must remain firm throughout the life of the contract. Discount off list price must be clearly noted in the price quote to the member. All pricing must include the CES 1.25% administration fee.
- B. **New Technology and Products:** New products or related services announced by manufacturer and/or Contractor may be added to this existing contract. Pricing shall be equivalent to the percentage discount of other product(s); is substantially superior to the original product(s) offered; is discounted in a similar or to a greater degree; and if the product(s) meet the requirements of the original RFP. No products may be added to avoid competitive procurement procedures. CES is responsible for approving any product, service or technology for this contract. CES can reject any approved additions, any new product, service or technology for this contract, without cause.
- C. **Price Quote/Proposal:** When preparing a quote/proposal under a CES awarded contract, the Offeror must clearly identify and break out quantities, descriptions, supplies, materials, equipment and services into individual line items as they appear on the Offeror's awarded price schedule or pricing methodology. At a minimum all quotes or proposals shall include the following: description, "hourly labor rate or the list/catalog unit price", "the per cent discount offered" and the final "CES price". All stated prices must include the CES one point two five percent (1.25%) administrative fee. Shipping/Freight costs and the New Mexico Gross Receipts Tax as applicable must be stated in separate lines.
- D. **Price Reduction, Promotional and Special Pricing:** A price reduction can be offered at any time and will become effective upon approval by CES. CES reserves the right to approve or disapprove such requests.
- E. **Price Increases:** Anytime during the life of the contract, pricing can be updated (increased/decreased) with proper justification letter from the manufacturer or distributor thereof and will become effective upon approval by CES. CES reserves the right to approve or disapprove such requests.
- F. **Price Surcharges:** Depending on current market conditions, surcharges may apply as approved by CES.



CERTIFICATE OF LIABILITY INSURANCE

DATE (MM/DD/YYYY)

11/7/2025

THIS CERTIFICATE IS ISSUED AS A MATTER OF INFORMATION ONLY AND CONFERS NO RIGHTS UPON THE CERTIFICATE HOLDER. THIS CERTIFICATE DOES NOT AFFIRMATIVELY OR NEGATIVELY AMEND, EXTEND OR ALTER THE COVERAGE AFFORDED BY THE POLICIES BELOW. THIS CERTIFICATE OF INSURANCE DOES NOT CONSTITUTE A CONTRACT BETWEEN THE ISSUING INSURER(S), AUTHORIZED REPRESENTATIVE OR PRODUCER, AND THE CERTIFICATE HOLDER.

IMPORTANT: If the certificate holder is an ADDITIONAL INSURED, the policy(ies) must have ADDITIONAL INSURED provisions or be endorsed. If SUBROGATION IS WAIVED, subject to the terms and conditions of the policy, certain policies may require an endorsement. A statement on this certificate does not confer rights to the certificate holder in lieu of such endorsement(s).

PRODUCER Arthur J. Gallagher Risk Management Services, LLC 300 Madison Avenue 28th Floor New York NY 10017	CONTACT NAME: AJG Service Team PHONE (A/C. No. Ext): 212-994-7020 E-MAIL ADDRESS: GGB.WSPUS.CertRequests@ajg.com	FAX (A/C. No):	
	INSURER(S) AFFORDING COVERAGE		
INSURED WSP USA Inc. One Penn Plaza New York, NY 10119	INSURER A: Liberty Insurance Corporation		NAIC # 42404
	INSURER B: Zurich American Insurance Company		16535
	INSURER C:		
	INSURER D:		
	INSURER E:		
	INSURER F:		

COVERAGES

CERTIFICATE NUMBER: 1287552564

REVISION NUMBER:

THIS IS TO CERTIFY THAT THE POLICIES OF INSURANCE LISTED BELOW HAVE BEEN ISSUED TO THE INSURED NAMED ABOVE FOR THE POLICY PERIOD INDICATED. NOTWITHSTANDING ANY REQUIREMENT, TERM OR CONDITION OF ANY CONTRACT OR OTHER DOCUMENT WITH RESPECT TO WHICH THIS CERTIFICATE MAY BE ISSUED OR MAY PERTAIN, THE INSURANCE AFFORDED BY THE POLICIES DESCRIBED HEREIN IS SUBJECT TO ALL THE TERMS, EXCLUSIONS AND CONDITIONS OF SUCH POLICIES. LIMITS SHOWN MAY HAVE BEEN REDUCED BY PAID CLAIMS.

INSR LTR	TYPE OF INSURANCE	ADDL INSD	SUBR WVD	POLICY NUMBER	POLICY EFF (MM/DD/YYYY)	POLICY EXP (MM/DD/YYYY)	LIMITS
B	<input checked="" type="checkbox"/> COMMERCIAL GENERAL LIABILITY <input type="checkbox"/> CLAIMS-MADE <input checked="" type="checkbox"/> OCCUR GEN'L AGGREGATE LIMIT APPLIES PER: <input checked="" type="checkbox"/> POLICY <input type="checkbox"/> PRO-JECT <input type="checkbox"/> LOC OTHER:	Y	Y	GLO9835819-12	5/1/2025	5/1/2026	EACH OCCURRENCE \$ 3,500,000 DAMAGE TO RENTED PREMISES (Ea occurrence) \$ 3,500,000 MED EXP (Any one person) \$ 10,000 PERSONAL & ADV INJURY \$ 3,500,000 GENERAL AGGREGATE \$ 14,000,000 PRODUCTS - COMP/OP AGG \$ 7,000,000 \$
A	<input checked="" type="checkbox"/> AUTOMOBILE LIABILITY <input type="checkbox"/> ANY AUTO <input type="checkbox"/> OWNED AUTOS ONLY <input type="checkbox"/> SCHEDULED AUTOS <input type="checkbox"/> HIRED AUTOS ONLY <input type="checkbox"/> NON-OWNED AUTOS ONLY			AS7-621-094060-035	5/1/2025	5/1/2026	COMBINED SINGLE LIMIT (Ea accident) \$ 5,000,000 BODILY INJURY (Per person) \$ BODILY INJURY (Per accident) \$ PROPERTY DAMAGE (Per accident) \$ \$
	<input type="checkbox"/> UMBRELLA LIAB <input type="checkbox"/> OCCUR <input type="checkbox"/> EXCESS LIAB <input type="checkbox"/> CLAIMS-MADE DED RETENTION \$						EACH OCCURRENCE \$ AGGREGATE \$ \$
A	<input checked="" type="checkbox"/> WORKERS COMPENSATION AND EMPLOYERS' LIABILITY <input type="checkbox"/> ANY PROPRIETOR/PARTNER/EXECUTIVE OFFICER/MEMBER EXCLUDED? (Mandatory in NH) If yes, describe under DESCRIPTION OF OPERATIONS below	Y/N	N/A	WA7-62D-094060-015 WA7-62D-095609-075 WC7-621-094060-915	5/1/2025 5/1/2025 5/1/2025	5/1/2026 5/1/2026 5/1/2026	<input checked="" type="checkbox"/> PER STATUTE <input type="checkbox"/> OTHER E.L. EACH ACCIDENT \$ 2,000,000 E.L. DISEASE - EA EMPLOYEE \$ 2,000,000 E.L. DISEASE - POLICY LIMIT \$ 2,000,000

DESCRIPTION OF OPERATIONS / LOCATIONS / VEHICLES (ACORD 101, Additional Remarks Schedule, may be attached if more space is required)

THIRTY (30) DAYS NOTICE OF CANCELLATION.

Project Number: US0036517 | Project Description: City of Santa Fe Midtown

City of Santa Fe their officials, officers, employees, and agents are included as Additional Insured with respect to the General Liability policy as required by written agreement, pursuant to and subject to the policy's terms, definitions, conditions and exclusions. The coverage provided by the General Liability policy is primary and any other coverage shall be excess only, not contributing. Waiver of Subrogation applies to Additional Insured with respect to the General Liability and Workers Compensation / Employers Liability policies as required by written agreement, pursuant to and subject to the policy's terms, definitions, conditions and exclusions.

CERTIFICATE HOLDER**CANCELLATION**

City of Santa Fe
 City of Santa Fe Public Works
 2651 Siringo Road, Building E
 Santa Fe NM 87504

SHOULD ANY OF THE ABOVE DESCRIBED POLICIES BE CANCELLED BEFORE THE EXPIRATION DATE THEREOF, NOTICE WILL BE DELIVERED IN ACCORDANCE WITH THE POLICY PROVISIONS.

AUTHORIZED REPRESENTATIVE

© 1988-2015 ACORD CORPORATION. All rights reserved.



City of Santa Fe, New Mexico

Memorandum



DATE: March 28, 2024

TO: Governing Body

VIA: Regina Wheeler, Public Works Department Director ^{RW}
 Rich Brown, Community Development Director ^{Richard Brown}

FROM: Tim Farrell, Facilities Division, Property Development Manager ^{Timothy Farrell}

ACTION:

Request for the Approval of Amendment #1 to the Professional Services Contract with WSP USA, Inc. for Owner Representative Services to Support Infrastructure Redevelopment at Midtown to Increase the Not to Exceed Amount to \$1,000,000 Annually, Including NMGR . (Tim Farrell, Facilities Division Property Development Manager, tgfarrell@santafenm.gov, 505-490-1659)

BACKGROUND AND SUMMARY:

Pursuant to Resolution #2022-12, the Midtown Master Plan was adopted by the Governing Body on November 30, 2022 (Resolution #2022-68), and the Midtown Community Development Plan was adopted on January 25, 2023 (Resolution #2023-5). Also pursuant to Resolution #2022-12, the City of Santa Fe released requests for proposals (RFPs) for the redevelopment of the Midtown Studios Production Lot, the Visual Arts Center, and Garson Theater in December 2022. An Early Negotiation Agreement (ENA) for the development of the Midtown Studios Production Lot was approved by the Governing Body on July 26, 2023.

To support Midtown planning and redevelopment efforts, a contract was executed with WSP for Owner Representative services for infrastructure planning, design and construction project management. WSP brings urban redevelopment expertise to help plan and guide the infrastructure work at Midtown. WSP, as Owner Representative Contractor, is helping to manage Midtown sitewide stormwater, utilities, roadway and spine infrastructure planning, coordination of infrastructure work by developers and developing the critical path schedule. They have also assisted with parcellation and development negotiations as needed. WSP continuing in this role, to project manage infrastructure development, is critical to continuing progress on Midtown redevelopment and meeting developer timelines.

Work will be issued to WSP by task orders and associated purchase orders with funding from various sources as the project proceeds. Initial funding was from FY23 GRT earned in excess of budgeted revenues, and the next funding source will be 2021, 2022 and 2023 legislative appropriations for Midtown Redevelopment.

PROCUREMENT METHOD:

The procurement method is the Cooperative Educational Services Price Agreement (CES) CES Contract #'s 2023-01-C211-ALL which expires on October 5, 2026.

FUNDING SOURCE:

Project Name/Ledger ID: Midtown Improvements/MTC245250D-Design
Fund Name/Number: MIDTOWN CIP/525
Munis Org Name/Number: MTC CapPrj/5250610
Munis Object Name/Number: WIP Design/572960

ATTACHMENTS:

WSP Amendment #1

WSP Contract

WSP Proposal(s)

WSP Project Schedule

WSP Procurement Documents (CES)

WSP Certificate of Insurance

WSP Business License

Summary of Contracts

Procurement Checklist

**CITY OF SANTA FE
AMENDMENT No. 1 TO
Professional Services Contract
ITEM#24-0112**

This AMENDMENT No. 1 (the "Amendment") amends the CITY OF SANTA FE Professional Services CONTRACT, dated February 21, 2024 (the "Contract"), between the City of Santa Fe (the "City") and WSP USA, Inc. (the "Contractor"). The date of this Amendment shall be the date when it is executed by the City and the Contractor whichever occurs last.

RECITALS:

A. Under the terms of the Contract, Contractor has agreed to provide the City of Santa Fe with Owner's Representative Services to implement the Infrastructure of the Midtown Master Plan and Community Development Plan.

B. Pursuant to Article 15 of the Contract, and for good and valuable consideration, the receipt and sufficiency of which are acknowledged by the parties, the City and the Contractor agree as follows:

1. COMPENSATION.

Article 4, paragraph A of the Contract is amended to increase the amount of compensation for fiscal year 2024 to nine hundred and ten thousand dollars (\$910,000.00) and then one million dollars (\$1,000,000.00) per fiscal year thereafter for a total of three-million nine hundred and ten thousand dollars (\$3,910,000.00), so that Article 3, paragraph A reads in its entirety as follows:

A. The City shall pay to the Contractor in full payment for services satisfactorily performed based upon milestones, such compensation not to exceed for fiscal year 2024, nine hundred and ten thousand dollars (\$910,000.00) including gross receipt tax, and then such compensation not to exceed one million dollars
CoSF

(\$1,000,000.00), including gross receipts tax, per fiscal year thereafter. **The total amount payable to the Contractor under this Agreement, including gross receipts tax and expenses, shall not exceed Three Million Nine Hundred and Ten Thousand Dollars (\$3,910,000.00). This amount is a maximum and not a guarantee that the work assigned to be performed by Contractor under this Contract shall equal the amount stated herein. The parties do not intend for the Contractor to continue to provide services without compensation when the total compensation amount is reached. Contractor is responsible for notifying the City when the services provided under this Contract reach the total compensation amount. In no event will the Contractor be paid for services provided in excess of the total compensation amount without this Contract being amended in writing prior to those services in excess of the total compensation amount being provided.**

2. TERM:

Article 5 of the Contract is hereby deleted in its entirety and substitute the following Article 5 in its place:

THIS CONTRACT SHALL NOT BECOME EFFECTIVE UNTIL APPROVED BY THE CITY. This Contract shall terminate **December 31, 2028**, unless terminated pursuant to paragraph 4 (Termination), or paragraph 5 (Appropriations).

3. CONTRACT IN FULL FORCE.

Except as specifically provided in this Amendment, the Contract remains and shall remain in full force and effect, in accordance with its terms.

IN WITNESS WHEREOF, the parties have executed this Amendment No. 1 to the Contract as of the dates set forth below.

CITY OF SANTA FE:

CONTRACTOR: WSP USA, Inc

Alan Webber (Apr 30, 2024 14:55 MDT)

Daniel Sims (Mar 25, 2024 08:49 MDT)

ALAN WEBBER, CITY MAYOR

DANIEL SIMS,
SENIOR VICE PRESIDENT

DATE: Apr 30, 2024

DATE: Mar 25, 2024

CRS # 01195458005

Registration # 230689

ATTEST:

GERALYN CARDENAS (Apr 30, 2024 16:00 MDT)

GERALYN CARDENAS, INTERIM CITY CLERK
GB MTG 04/24/24 *XIV*

CITY ATTORNEY'S OFFICE:

Kevin L. Nault (Mar 25, 2024 11:46 MDT)

ASSISTANT CITY ATTORNEY

APPROVED FOR FINANCES:

EMILY OSTER, FINANCE DIRECTOR

Proposal for

OWNER'S REPRESENTATIVE AND PROJECT MANAGEMENT SERVICES FOR MIDTOWN REDEVELOPMENT

February 1, 2024



1 February 2024

Ms. Regina Wheeler
Director of Public Works
500 Market Station, Suite 200
Santa Fe, NM 87501

Re: Owner's Representative and Project Management Services for Midtown Redevelopment

Dear Regina:

WSP is pleased to submit this proposal to support the City's strategic initiative to redevelop the Midtown Campus, consistent with the adopted Master and Community Development Plans. WSP's services will support the City and its existing team to accomplish:

DELINEATING THE DETAILS. Establishing and choreographing a detailed plan for implementing this transformational urban redevelopment, building from the Master and Community Development Plans.

SOLIDIFYING PARTNERSHIPS. Supporting collaborative solicitations and negotiations with developers and tenants.

ACCELERATING THE VISION. Accelerating delivery of infrastructure, adaptive reuse and new development to attain the Midtown vision faster.

EXPERIENCED RESOURCES. Providing a bench of locally and nationally experienced resources to support the existing exceptional team in getting the job done.

REPRESENTING YOU. Advocating for the City's interests, with full fidelity to the hard won efforts represented in adopted vision for Midtown.

This proposal includes two phases. Phase 1 is structured to meet the City's immediate needs within the staff level procurement authority. Phase 2 provides the balance of the services for the duration of the contracting period. WSP is flexible and happy to make revisions, should you need it. An existing contract with the Cooperative Educational Services is the vehicle for this purchase order.

The team assembled for this initiative is extraordinarily excited to be a part of this transformation. It is exactly the type of work we enjoy doing and feel fortunate to be invited by the City to undertake it. Santa Fe is a wonderful, richly diverse community. Moreover, we already see the strength of the collaboration between City and WSP staff. Thank you.

Sincerely,

WSP USA Inc.



Manjeet Ranu, AICP
National Planning Lead
Senior Vice President
Principal In-charge

UNDERSTANDING

Background

The City of Santa Fe undertook a series of interrelated actions to approve and implement the Midtown Master Plan and Midtown Community Development Plan in late 2022 into early 2023. A repository of information is available at www.midtowndistrictsantafe.org and on [PrimeGov](#), the City's docketing platform. The City has begun the implementation phase for the redevelopment of the Midtown campus site (Midtown) by soliciting proposals for (1) public infrastructure design and (2) from developers for the purchase or lease of land and existing buildings—disposition and development agreements (DDAs) would follow. Page 27 of the Community Development Plan sets forth the anticipated phasing.

Purpose and Need

The City is looking to partner with an Owner's Representative highly experienced in urban redevelopment to align with Santa Fe's distinctiveness and expectations of substantial community benefits to implement the Midtown Master Plan, consistent with the Midtown Community Development Plan. This work will include coordination with City leadership on the engagement of developer(s) to complete the redevelopment of 64 acres of City-owned property (the "District") starting now. The immediate priorities are:

1. Assist the City with developer negotiations toward DDAs, which are guided by existing and imminent exclusive negotiation agreements.
2. Prepare an initial program management plan (PMP), which will be informed by developing a deeper understanding of the situation through the lens of WSP's deep urban redevelopment experiences.
3. Assist the City with the public infrastructure (utilities, mobility, public realm/open space) process to ensure the infrastructure is designed and constructed to support the proposed program.

As the City's Owner's Representative, WSP's role and responsibility is to provide expertise and oversight of this complex urban redevelopment program of many projects to be planned, developed, designed and delivered over the years and in doing so, advocate for the City's interests, with fidelity to the Master Plan and its implementation Community Development Plan. WSP understands it will need to be rapidly responsive as an additional resource to the City, which may necessitate occasional, focused civil engineering and urban design services when directed to undertake these, as appropriate and in consideration of WSP's role.

Turning the Master Plan Into Reality

The City's Master Plan process has created a development program that will transform the Midtown Campus into a vibrant, pedestrian-friendly, mixed-use district. The new district will provide significant public and economic opportunities that will yield new affordable housing, market rate housing, a new library, job growth, and new public spaces. In addition, four elements were identified to guide sustainable development: Equity, Economy, Culture and Environment.

The District should be developed to connect with, have a positive impact on, and serve as an economic catalyst for the diverse and vibrant surrounding neighborhoods in Santa Fe. It should incorporate land use policies and guidelines that equitably generate increased value through the repositioning of assets that can be used to fund capital investments, thus creating a self-sustaining funding structure that captures the value created by the development. Revenue will be generated through the sale or long-term leasing of land and the introduction of ongoing tax revenue from new development. A vibrant district with a new library, housing, commercial, entertainment, open spaces, accessibility, improving walkability and transportation choices, creating jobs, and advancing climate change resiliency will enhance the experience for those that live in and adjacent to the District, and will create a compelling and walkable experience for residents and visitors. All of this shall be undertaken consistent with the Master Plan and Community Development Plan.

The Midtown Master Plan identified the opportunity for over 1,000 housing units, film production facilities, cultural and employment uses, and over five acres of public parks and open spaces. To deliver this development, the City will need to assess future infrastructure needs and financial feasibility, develop policies and guidelines that ensure that the City's goals are met, and engage with the market to generate interest and align expectations.

Delivery of a vibrant District will require a nuanced understanding of the real estate market locally and the national context that influences it. WSP is well suited to work with the City to deliver on the vision for developing the District into a vibrant, equitable neighborhood with a mix of commercial, residential, entertainment, cultural and open space uses that are part of a walkable, environmentally and financially sustainable district with a uniquely Santa Fe sense of place.

Adaptation and Resiliency to Complexity

Developing the District is a complicated and long-term undertaking. Challenges will arise, constraints will change, economic and market conditions will change, and opportunities will present themselves. For the City to successfully deliver the Midtown Master Plan vision, it will require an Owner's Representative that clearly understands, believes in, and is committed to the project goals, and is able to provide the necessary and appropriate guidance to the City as it develops the District based on lessons learned from other projects. WSP will work with the City on understanding the local real estate market and bring vast knowledge of national market trends and the economic development tools available to the City. Further WSP has extensive local, regional, and national experience bringing equitable, mixed-use, public-private development projects from vision to reality.

One additional challenge will be to navigate the political environment that elevates and evolves during the course of these types of projects. There are numerous concerns, and it will be necessary to define the benefits accrued from this project in the broadest sense possible. We have been successful in navigating such issues by anticipating the discussions and providing multiple and flexible paths to success. It will be important to understand at the commencement of this work, what the political environment entails and how it has been previously addressed.

Governance

The City intends to establish a Metropolitan Redevelopment Agency (MRA) to administer the Metropolitan Redevelopment Area, as a division of the City, to spearhead the implementation of the

City's Midtown Master Plan. MRA, the City and WSP will work together in partnership to ensure an experienced team comprised of planning, development and construction professionals to facilitate implementation. To accomplish its mission, MRA will collaborate with the various City and State entities and agencies, and key stakeholders that are involved in funding, financing, planning, development and construction.



URBAN REDEVELOPMENT CORE COMPETENCIES & SERVICES

Collaboration and Differentiation Between Public and Private Sectors

Implementing the Master Plan into an equitable, vibrant, mixed-use neighborhood will require a collaborative effort between the public and private sectors, with appropriate risk allocation. The City, with the support of WSP, will take the lead in creating a Public Framework — mobility, utilities, and a connected and high-quality streetscape linked to a series of public open spaces comprising the public realm. Within these areas, private sector development opportunities will be implemented in alignment with the City’s goals and objectives to redevelop the site and benefit surrounding communities. Our initial approach to delivering the vision for the District is straightforward — the City will design and construct a Public Framework and establish the criteria for the subsequent private sector development.

Creating a District that is uniquely Santa Fe and facilitating equitable private sector development with land uses important to the City is the best way to create value within the District and the surrounding communities. The vision and corresponding value to be created by the District are best accomplished by the consistent and coordinated evaluation of the goals and components of the District — transportation infrastructure and utilities, parking, streetscape and open space, and mixed-use development.

Delivering the Vision

To attract the designers, developers, and contractors needed to deliver the vision set forth in the Midtown Master Plan, it is important that the City and WSP work to clearly establish the point of view needed to orchestrate the work of all the partners that will create a vibrant, equitable, mixed-use district. WSP has experience leading significant and complex initiatives that require the orchestration of engineering, building design, public space design, construction, economics, project financing, real estate development, and business — everything necessary to create the District. WSP will help to implement the design guidelines and zoning identified in the Master Plan necessary to create a genuine sense of place within the District and establish the responsibilities of the public and private sectors. This is an important early step in the delivery of the District as it will provide direction to the various entities responsible for the design of the Public Framework and the development.

Market Capacity and Feasibility Analysis

WSP will prepare or update the market analysis to support negotiations for private sector development. We will analyze the financial feasibility of the development program, the ability of the Santa Fe market to absorb it, and develop an understanding of the District’s land values. As part of this work, we will conduct a study and analyze the details related to equitable development and the desired outcomes.

This analysis of private sector development opportunities will be coordinated with an ongoing analysis of the existing and planned infrastructure capacity in the District — streets, public transit connections, pedestrian access and walkability, utilities, parking, and public spaces. We will also review the associated project costs and requisite need for public facilities that the private sector development will generate. Our analysis will focus on both the necessary infrastructure and opportunities for the placemaking needed to create a sense of place — an important aspect of enhancing the value of the District.

The market analysis will validate specific programming for each parcel that aligns the District vision with the projected capacity in the market for the various land uses, along with any desired constraints with

respect to density and size of development that the City believes to be in the best interest of Santa Fe residents. Critical in this analysis is an understanding of the balance between market demand, site constraints and developer feedback through market soundings.

Accurate Cost Estimating

WSP believes it is important to fully understand, through rigorous analysis, the costs of delivering the vision, funding sources, financing tools, and the appropriate allocation of risk and control. The Master Plan provides the foundation upon which this next phase of work will be built. WSP will work with the City to develop a coordinated set of goals, objectives, and criteria for development of the District to ensure that the components of the Public Framework are aligned with the development opportunities. We will advance the criteria for private sector development to reflect City policy, market conditions, or project context to ensure the vision for private sector development is feasible and will generate a strong market response.

Identifying and Allocating Risk Facilitates Rapid and Fiscally Efficacious Implementation

Mapping the risk profile of the Program will allow the City to assess how attractive the redevelopment program might be to the private sector. The more opportunities for a project to create value with proper risk allocation, the more likely the project is to be identified as a viable, development-ready project. Preparing the risk registry begins when this program commences. Our work will advise on the appropriate risk allocation between the City and private sector, and considering for each case, should it be completely transferred to the potential developer, retained by the City, or a shared alternative. The WSP team has successfully supported clients in quantitative and qualitative risk analyses. WSP brings a unique perspective to risk due diligence from its work analyzing the commercial, technical, financial, and operational plans for proposed redevelopment programs, including P3s. Every P3 is different and the WSP team's difference is we have supported many P3 explorations, procurements and projects as an Owner's Representative in a variety of different contexts.

Funding and Financing Strategy

WSP will evaluate a range of funding and financing tools and develop an approach to funding and financing development in the District, including capital construction and ongoing maintenance and operating costs. This analysis will include a quantitative and qualitative evaluation of the tradeoffs between public delivery of some or all infrastructure improvements, the practical and financial implications of shifting risk for infrastructure improvements to the private sector, and the suitability of P3 delivery models for certain portions of the District. The WSP Team will evaluate investments from multiple perspectives to understand the potential for value creation and value capture. We will analyze the potential to generate revenue for or finance public investment through a variety of state and local special districts.

With dozens of acres of vacant land, much of which is presently tax exempt, tax increment financing is a promising option to support new public infrastructure. We will also explore the potential to generate revenue through the ground lease or disposition of public land, mostly vacant today, for vertical development and renovation of existing buildings. We will explore how to fund ongoing operations and maintenance through revenue sources, such as from a ground lease, retail or advertising revenue.

This analysis will include developing recommendations for leveraging federal, state, and local funding sources, bonding capacity and potential of the tax increment financing, and ground lease or property disposition revenues. This evaluation will include how to best leverage future development values and private sector efficiencies to deliver new infrastructure and development while managing public risk.

Defining a Project Implementation and Development Strategy

The aspect of the Public Framework that will have the most significant impact in establishing the character and level of quality of the District is the streetscape and public open space network. The City will want to engage a prominent landscape architecture team to create the design for the streetscape and public spaces within the District in a holistic and comprehensive way. Public investment in high-quality public spaces is an effective tool for increasing the value of adjacent real estate and there are numerous examples throughout the country of the transformative impact of investment in the public realm.

The District is ultimately about the land uses that will complement and animate the public spaces. WSP will assist the City in securing development partners for City-owned parcels in the District. We will work closely with the City to evaluate the range of development options, which may include the sale or lease of real estate to a single master developer or the sale or lease of individual parcels to a series of developers, with the City retaining control of the development of the public spaces within the District. All of this will be evaluated in terms of the desire to deliver certain components of the District early — the film production site, performance and visual arts spaces, and the Fogelson Library — and that the total development within the District could occur over the next 10 to 20 years.

The anticipated phasing set forth on page 27 of the Community Development Plan intentionally reflects the community's priorities to realize the benefits from this redevelopment site in alignment with the distinctiveness of Santa Fe. A strategic approach to phasing enables the site to grow as an organic, connected and active piece of the city's urban fabric. Our extensive understanding of the design and construction of urban redevelopment programs will be beneficial to understand costs and how they may affect phasing for redevelopment. A phasing plan that coordinates investments by public agencies and expectations for private sector investments will assist in expediting beneficial redevelopment. Phasing is influenced by many factors that will gain greater focus during the implementation phase. Stakeholder governance and political environment; infrastructure and other requirements; schedule constraints and opportunities; financing, including funding constraints and opportunities; market capacity; and other pertinent considerations based on lessons learned all influence successful implementation.

Constructing the Improvements

Design of the three components (utilities, mobility, open space) of the Public Framework will begin at roughly the same time. The City, with the support of WSP, will oversee and ensure that the work of each is coordinated, making the necessary decisions along the way to balance the individual objectives of each component of the Public Framework. This will ensure that the built improvements best meet the overall goals set forth in the Master Plan and are consistent with the expectations of the residents of Santa Fe.

Securing Development Partners

WSP will evaluate the District and create specific development opportunities to be marketed to the private sector to achieve the City's goals and best deliver value to the City. We will assist the City in issuing site specific RFPs for developers for the City-owned parcels. WSP will assist the City in organizing and managing the developer solicitation process.

Managing the Private Sector Developer Relationship

WSP will assist the City during the term of our agreement in the management of the ongoing relationship with the firms responsible for the development of land within the District and will advise the City as the design of the District development projects are submitted by developers to ensure that they meet the design guidelines, District objectives, and respective development agreements. WSP will also monitor the progress of the development to assure compliance with any schedule milestones or contractually obligated submissions required of the developer.

Stakeholder Communication

Collaboration with a client, and key internal/external stakeholders working together to achieve a common goal are the best approach for successfully delivering a project of this magnitude. This requires the implementation of various internal and external project, client, and stakeholder engagement forums with the sole purpose of sharing ideas and perspectives that will help move the project forward. Enabling visibility, knowledge sharing and openness among all participants is an essential step in building consensus and support for the implementation of the Midtown Master Plan.



SCOPE OF WORK

The purpose of the Owner’s Representative services described in this scope of work is to assist and represent the City of Santa Fe as to establish and oversee an ongoing programmatic approach to implement the Santa Fe Midtown Redevelopment Program in accordance with the Midtown Master Plan and Community Development Plan (“Program”).

The redevelopment of the Santa Fe Midtown Site includes a goal of advancing sustainable, resilient, and regenerative development, while creating green infrastructure that serves as interactive public amenities and learning experiences. The Plans support the development of a mixed-use district with block, street, open spaces, parcel, and density patterns and designs that create a walkable, health-oriented, connected, multi-modal urban place. The approaches to and outcomes of this scope of work shall be guided by and support that vision.

The Owner’s Representative (“WSP”) will provide on-call services to the City for pre-development through development activities. Work will be phased in alignment with private and City development plans at the site. Infrastructure includes all components of public rights-of-way streets, drainage, and sidewalks, trails, parks, civic spaces, and open space, and the combined stormwater management system.

WSP will report to Regina Wheeler, Director of Public Works, until a formal governance structure for the Program is established. After the MRA is established and its Director onboarded, WSP would report to that Director.

PHASE 1 IMMEDIATE SCOPE OF WORK

Phase 1 is structured to immediately commence the supporting services in three key focus areas for a time and materials, not-to-exceed fee of \$150,000.00.

TASK 1.1 – INITIAL PROGRAM ESTABLISHMENT

WSP will mobilize immediately to develop the basic structure and framework to support the redevelopment program.

- Initial discussions regarding the governance structure and mapping out the path forward
- Prepare an initial Critical Path Schedule based on the City’s current information
- Organize a regular meeting schedule and process

TASK 1.2 – INFRASTRUCTURE ENGINEERING/TECHNICAL REVIEW SERVICES

WSP identify the immediate needs to organize the civil engineering and public realm works.

- Assist the City in writing or reviewing the initial infrastructure scope(s) and/or RFPs for utilities, mobility, open spaces/parks/public realm, or other key infrastructure
- Assist the City in the review and selection of the most qualified design team(s)

TASK 1.3 – FILM STUDIO PRODUCTION LOT DEVELOPER NEGOTIATIONS SUPPORT

The City is seeking a developer and operator for the redevelopment and expansion of the existing film production studios into a state-of-the-art production studios with pre- and post- production facilities that attracts local, regional, national, and global productions. The City has selected or will soon select a preferred developer for designation and to enter into an exclusive period of negotiation.

WSP will provide support in the negotiation of business and infrastructure terms pertaining to Disposition and Development Agreement (DDA) for the redevelopment and expansion of the Midtown Studio Production Lot for a period of 60 days.

Specific Tasks:

- Assist the City’s legal team in reviewing proposed business terms, primarily for reasonableness.
- Assist in the research of similar film production transactions to provide order of magnitude benchmarks.
- Identification of potential future capital event opportunities for inclusion in transaction documents.
- Analysis of specific terms as they are proposed to identify potential opportunities and risks.
- Identify potential terms, conditions, and counterproposals for inclusion in transaction documents.

PHASE 2 OVERALL AND ONGOING SCOPE OF WORK

TASK 2.1 – INITIAL PROGRAM ESTABLISHMENT

A. Support in Establishing a Governance Structure

Support City staff in establishing a governance structure for the Program. Such governance structure is expected to be in the form of an MRA.

- Description of the process and needs for establishing an MRA under Santa Fe ordinance and New Mexico statute
- Recommendations for representation within the MRA board and staff support needed to ensure City needs are represented
- Preparation of documentation supporting creation of the MRA and founding governance structures
- Identification of staff roles and responsibilities for the MRA, as well as other resources that will be required to function effectively
- Development of an interagency coordination plan to ensure the MRA is able to communicate and work with relevant City agencies and key stakeholders

B. Preparation of a Project Management Plan (PMP)

Prepare a Project Management Plan (PMP) to inform establishing a governance structure, development of a Critical Path Schedule, and other key activities to achieve the vision described in the Midtown Master Plan and Community Development Plan.

PMP



C. Development of a Critical Path Schedule

Prepare a Critical Path Schedule based on the Midtown Master Plan and Community Development Plan.

- Initial schedule to focus on the first two (2) years
- Phasing plan to include public infrastructure improvements and anticipation of market readiness in alignment with the funding plan and PMP
- Entitlements, zoning, design and other actions necessary to implement public infrastructure and ready parcels for development
- Expected release of parcels for development including funding, design and construction timeframes
- Procurement processes and milestones for infrastructure and developers

D. Development of a Risk Management Plan

- Identify potential schedule risks
- Create a risk register

- Work with the City to prioritize these risks and identify mitigation and allocation strategies to manage schedule and other project risks with emphasis on addressing the critical path schedule and appropriate risk allocation to promote implementation

E. Preparation of a Funding Plan

Prepare a Funding Plan for the Program based on the preliminary time-based financial plan for the needs analysis.

- Expected costs for infrastructure and developer incentives, including timing for the outlay of those costs
- Available funding and financing sources including grants (state legislative grants, federal grants, NMDOT grants, environment department grants); value capture mechanisms (TID, PID); bond revenue; private and public financing, including timing for when the funding/financing will be needed.

F. Acceleration and Parcelization Recommendations

- Perform three (3) analyses to understand market demand for commercial real estate development at the Midtown site to ascertain opportunities and strategies for accelerated delivery to achieve the Midtown redevelopment faster. Building on any available previously completed reports and analyses, the WSP team will seek to understand where and what type of development is most in demand and will provide estimates of absorption of new product for the Midtown site as determined by the existing Master Plan.
- Subtask One is performing a quantitative analysis of historical growth rates of real estate development. This establishes an understanding of a “market-driven” pace of growth that can be compared to the pace of growth anticipated to generate new development outlined in current plans and visions. Our analysis of CoStar data includes office and retail (square feet), as well as multi-family residential units and hotel rooms. Completing this analysis allows us to understand timing for the market to deliver development in envisioned types, uses, and locations. This also provides a picture of how different (or similar) envisioned future development would be to past historical development, generating insight into how much (or how little) effort will be required to redirect and reshape the development market.
- Subtask Two is a review of the various potential sites identified in the Master Plan that could support new or adaptive development. Utilizing the existing proposed massing, the WSP team will perform a preliminary parcelization exercise to understand the amount and pace of the proposed development that would make sense on each parcel, utilizing the growth rates and demand forecasts developed in Subtask One.
- Subtask Three is conducting voluntary interviews—market soundings—with developers currently building and in the local market. The WSP team recommends between 6 and 12 interviews in order to deliver a strong understanding of their perception of the market, including reasonable building typologies, local community reception, and potential entitlement and financing hurdles that may exist. WSP will survey general questions of how the market is perceived, how developers understand feasibility, and what building typologies fit the financial, political, and physical constraints to make them buildable. At the conclusion of this task, WSP will synthesize feedback received from developers and

development-community stakeholders into recommendations for reinforcing (or changing) the incentives, restraints, and perceptions guiding developer decision making.

TASK 2.2 – PROGRAM IMPLEMENTATION

Provide expertise to support the implementation of the Program once the initial program is established, as follows:

A. Assessment of Public Infrastructure Improvements and Plans

- Design:
 - Prepare scope(s) of work for infrastructure design, including utilities, mobility, open space/parks and other key public infrastructure
 - Review of RFP responses and selection of most qualified design team(s), unless this is done thru an on-call contract or similar process
 - Oversight of design work, scope, budget, invoicing, and schedule
 - Coordinate phasing of design and construction schedules and solicitation process for public infrastructure
- Construction:
 - Prepare scope(s) of work
 - Review of RFP responses and selection of most qualified design team(s)
 - Oversight of construction, scope, budget, invoicing, and schedule

B. Assessment of Development Proposals and Plans

- Review of Developer pro formas and other financial and market documentation to assess the financial viability and responsiveness of the proposal
- Review of concept plans and other designs to assess the engineering and design feasibility and responsiveness of the proposal
- Review of commercial terms and other commercial aspects of the proposal (i.e., schedule, budget) to assess the feasibility and responsiveness of the proposal
- Prepare requests for additional information
- Assist with Developer due diligence requests, such as requests to access the property

C. Procurement of Development Proposals

- Prepare solicitations for Developer proposals
- Manage the procurement process including evaluation and negotiation
- Hold pre-positioning meetings with Developers to get feedback and input to ensure interest and that the RFP responses will be beneficial

D. Coordination and Negotiation of ENA, DDA and Other Agreements

- Assist with the establishment of Exclusive Negotiated Agreements as part of the preparation of a Development Agreement
- Assist with the negotiation, execution and ongoing management and administration of Development Agreements

E. Coordination with Third Party Stakeholders

- Engage adjacent property owners, utilities, and other third parties to assess potential impacts and risks to Program implementation.
- Develop and negotiate agreements with such third parties as necessary.

TASK 2.3 – DEVELOPER SOLICITATION SUPPORT

WSP will provide on-going support in the RFP, ENA, and DDA phases for developers for the redevelopment and expansion of the development parcels defined in the City's Program.

- Provide support for development parcels from RFP preparations and issuance thru DDAs and other administration of developer solicitations
- Prepare RFP scopes of work for developers
- Evaluate Developer RFP responses
- Assist the City's legal team in reviewing proposed business terms, primarily for reasonableness
- Analysis of specific terms as they are proposed to identify potential opportunities & risks
- Identify potential terms, conditions, and counterproposals for inclusion in transaction documents

TASK 2.4 – INFRASTRUCTURE ENGINEERING/TECHNICAL REVIEW SERVICES

WSP will provide technical review services in collaboration with the City related to the infrastructure for the Midtown Campus Redevelopment. The City intends to hire a separate engineering consultant(s) to act as the Engineer of Record (EOR) for the project. WSP will help to write or review the initial infrastructure scope(s) of work, review and select the most qualified firms, and review the deliverables developed by the EOR and provide comments and recommendations.

Technical reviews and services will include:

- Design Analysis Reports (DARs)
- Drainage Reports
- Design Plans at all phases (30%, 60%, 90%, Final)
- Conformance to standards and specifications
- Construction Contract Book, including but not limited to special provisions, Notices to Contractors, and/or other supplemental contract documents
- A/E Contract Exhibit Review
- Safety Studies
- Traffic Impact Analysis
- Lighting and Signalization Reports
- Engineering Estimates Opinions of Probable Cost
- Value Engineering

Reviews will be conducted utilizing Bluebeam software to track comments, verify changes and document design decisions. The EOR will be responsible for providing QC/QA on all deliverables prior to submittal to the City and review by WSP.

- A. Meetings and Field Visits: WSP will attend project development and review meetings in person or virtual depending on project needs.
- B. Deliverable Items: Technical review of design plans, studies, and other relevant data provided by engineering consultant at each design milestone (Bluebeam markup)
- C. Schedule: Dependent on project timeline determined by project needs and phasing.
- D. Assumptions
 - WSP will not provide design services
 - EOR is responsible for performing QC/QA on all deliverables prior to submitting to City and WSP

TASK 2.5 – STAKEHOLDER MEETINGS

A. Internal Stakeholder Meetings

WSP will integrate into the existing collaborative framework for the City Leadership Team to participate in and contribute to the advancement of the Midtown program, an internal City Stakeholder Committee will be formed that will meet monthly to discuss status and concerns related to the design and construction of the Midtown Master Plan. These meetings will be structured and take place on a set schedule throughout the life of the project. This team should include the City’s MRA team, representatives from the many participating departments.

B. External Key Stakeholder Meetings

Throughout the design and construction phase, WSP will be available to support briefing external stakeholders on progress at regular intervals. Often these meetings are structured and take place on a set schedule throughout the life of the project.

TASK 2.6 – ONGOING PROGRAM SUPPORT

- A. Project management of the Program including schedule, document management, funding plans, reporting, communications, and phasing of public infrastructure and private development
- B. Represent the City for purposes of the Program as such authority is delegated to the Owner’s Representative
- C. Coordinate other City consultants working on the Program including design and engineering, financial; and legal, as requested of the owner’s representative

TASK 2.7 – PROGRAM MANAGEMENT OF OWNER’S REPRESENTATIVE TEAM

- A. Submission of monthly invoices and monthly report
- B. Regular meetings and communication with the client

As part of our communication plan, and to ensure constant communication between the City and WSP, a weekly [or bi-weekly] Project Coordination Meeting will be established to allow for the

discussion and resolution of all topics and issues posed during the meeting. These meetings will be structured and take place on a set schedule throughout the life of the project. This forum will be used to structure the scope of the overall program, provide for communication, and reporting (cost estimating and controls, schedule controls, risk management, change management, claims management, occupational safety oversight, and value engineering). This meeting can also serve as a venue to provide updates to elected leadership and key project stakeholders as directed by the City team.

- C. Quality management of deliverables
- D. Meeting minutes and agendas
- E. Maintenance of project site and document management
 - All pertinent project records will be tracked and stored in good order, all documents and presentations will be professional, all invoices will include a progress report and be timely.
 - Ensure that all work products and supporting documents are maintained in a repository readily accessible to all team members



TEAM LEADERSHIP

Manjeet Ranu, Principal In Charge



Manjeet leads WSP's national planning practice in the United States. His leadership brings a vision that is comprehensive, multidisciplinary and leverages existing WSP services to meet the multidimensional opportunities and challenges facing current initiatives, and to make impacts that are broadly beneficial and equitable. His extensive leadership experience and exceptional expertise in both the public and private sectors across the country give him keen strategic perspectives to achieve outcomes through complexity. Manjeet has 26 years of progressively responsible public and private sector experience across Arizona, California, Colorado, Georgia, Texas and Utah. His areas of expertise are land use, transit and environmental planning, in addition to urban design, public engagement, capital programming and organizational management. Manjeet's public sector experience includes executive leadership roles with the Los Angeles County Metropolitan Transportation, Metropolitan Atlanta Rapid Transit and Utah Transit Authorities involving capital programs worth billions of dollars, as well as leadership of city planning and development services departments. In the private sector, he has provided planning and entitlement services for community developers, along with policy development for public agencies. Manjeet has also served as a community leader in coastal San Diego, and his work has added value to infrastructure projects and transformed these projects into valued community investments. Being from Colorado, he has visited Santa Fe many times over the years and it is one of his favorite places.

Aron Kirsch, Program Manager



A dedicated and highly engaged Program Manager, Aron brings a perfect combination of commitment, integrity and technical capability that will help drive our team to deliver high-quality results. Aron has more than 30 years of experience managing multi-billion dollar, large scale, transit-oriented, mixed-use projects from concept through construction in the public and private sectors. Aron will leverage his PM experiences on Hudson Yards in New York City, One Central in Chicago, and Kay Bailey Hutchinson Convention Center in Dallas. Aron was instrumental in New York City's implementation of the required public infrastructure improvements and developer solicitations for the Hudson Yards project, the conversion of a 300-acre, 60-block industrial hub and rail yards into a vibrant, equitable, 50-million square foot mixed-use neighborhood supported by mass transit.

Open and collaborative by nature, Aron listens intently to client and team member needs, asks the right questions, implements the responses, and enables a mutual understanding of project goals and objectives. His public and private sector experience enables the ability to balance the expectations and discussions for the client, stakeholders, architecture/engineering teams, contractors, and others. He has a keen ability to successfully deliver projects within schedule and on budget.

Aron's background is in public infrastructure and real estate development. He has knowledge and experience with zoning, transportation and land use planning, public financing mechanisms, environmental analyses, property acquisition and disposition, and business retention and attraction strategies. He has extensive experience and success in managing the planning, design, construction and financing of large-scale transit-oriented development projects, mid and high-rise buildings (residential, office, hotel), and public infrastructure projects.



City of Santa Fe

Regina Wheeler & Richard Brown

Principal-in-Charge & Fidelity to Midtown Plans

Manjeet Ranu

Program Manager

Aron Kirsch

⊕ = New Mexico staff

Program Delivery & Implementation	Communications & Public Involvement	Program Planning & Development	Buildings	Environmental Remediation & Compliance	Civil Engineering Lead
Jenifer Ross-Amato	Nick Fazio ⊕	Dan Baer	Mark Montgomery	Jennifer Hyre	Ray Trujillo ⊕
Financial Structures Peter Waldt Funding & Financing Tim Thornton Grants Miranda Braatz Delivery Methods Analysis & Procurement Judah Gluckman Property Disposition & Transactions, Third Party Agreements Sam Spencer Project Controls Andrew Piana Construction Management Ronald Roberts	Urban Design John Loughran Sustainability & Resiliency Amy DiCarlantonio Equity Heather Martin Landscape Architecture Todd Teuscher Market Acceleration Charles Warren	Drainage/Stormwater Dustin Davidson ⊕ Mobility Design Andrew Sutliff ⊕ Structures Mohit Athasniya ⊕ Mobility Engineering Jim Heimann ⊕ Water & Wastewater Chris Naidu ⊕ Dry Utilities Mark Montgomery			



MANJEET RANU

Senior Vice President, National Planning Lead



Years with the firm

1

Years total

26

CAREER SUMMARY

Manjeet Ranu is a comprehensive planning practitioner, having practiced in six high-growth, economically significant states as a land use, transportation and environmental planner, with urban design expertise. He was an executive for three large urban transportation agencies in the Los Angeles, Salt Lake, and Atlanta regions. He also led community development for cities in the San Diego and Dallas regions. His transit experience involved leading and administering transportation planning, capital programs, Federal Transit Administration Capital Investigation Grant program projects, National Environmental Policy Act and the California Environmental Quality Act. Areas of practice in land use include policy planning, master planning, development review, building safety, housing programs, preparing land use regulations, California Environmental Quality Act, and code enforcement. Manjeet’s 20 years of experience in the public sector and six years in the private sector across different regions of the United States, along with years of community leadership, has given him keen strategic insights and creativity to advance highly complex initiatives to successful outcomes with broad support and equitable impact.

EDUCATION

MUP, Urban and Regional Planning, University of Colorado-Denver	1999
MPA, Public Administration, University of Colorado-Denver	1999
BA, Biology & Political Science, University of Colorado-Boulder	1995

PROFESSIONAL MEMBERSHIPS

- American Institute of Certified Planners
- American Planning Association
- Urban Land Institute: Full Member

PREVIOUS EXPERIENCE

Before joining WSP, Manjeet’s experience included:

- **Chief of Capital Programs, Expansion, and Innovation, Metropolitan Atlanta Rapid Transit Authority, Atlanta, Georgia:** led a team of approximately 300 to execute a \$500 million annual planning, project development, design and delivery capital program to support expansion and state of good repair projects for Metropolitan Atlanta Rapid Transit Authority. Manjeet strategically guided federal discretionary funding pursuits anew, which the agency last undertook in the 1990s, building capacity to calibrate and deliver the capital program in collaboration with regional partners. He led the entry of two expansion projects, each valued at over \$300 million, into the Federal Transit Administration’s Capital Investment Grants program.
- **Director of Capital Development, Utah Transit Authority, Salt Lake City, Utah:** led a reinvigorated five-year, \$2 billion capital program involving light rail, bus rapid, and commuter rail transit corridor projects. Manjeet managed the federal, state, and local grants programs and administered enterprise-wide program management services, design criteria, and facilities planning.
- **Interim Planning Director, City of Denison, Dallas Region, Texas:** created processes and procedures to effectively manage significant development. Manjeet created a workflow platform to manage the development review process. He initiated the preparation of a new



MANJEET RANU

Senior Vice President, National Planning Lead

land use code with design guidelines. He also prepared a work program for the annexation of nearly 7,000 acres.

- **Senior Executive Officer, Los Angeles County Metropolitan Transportation Authority, Los Angeles, California:** guided the initial preparation of an update to the agency's 40-year long-range transportation plan involving \$500 billion in investments. Manjeet's responsibilities included planning, designing, and environmentally clearing \$30 billion in new or expanded rail, bus rapid transit, and active transportation capital projects.
- **Planning and Development Services Director, City of Tucson, Arizona:** provided an assessment of needs and identified recommendations to improve the department while facilitating beneficial land use and economic development opportunities. Manjeet established a GIS-based development and permitting activity map. He connected Tucson's mayor and City staff with the Daniel Rose Land Use Fellowship, a program of the National League of Cities and Urban Land Institute.
- **Acting Director, Deputy Director of Planning and Building, Planning Manager, City of Encinitas and City of El Cajon, San Diego Metropolitan Area, California:** transformed development services operations by creating a workflow tool and process guide and set performance standards. Manjeet oversaw all work related to the Coastal Act and California Environmental Quality Act. He was responsible for planning, building, housing, and code enforcement services.
- **Senior Planner, Professional Services Firms and Developer Owner Representative, San Diego, California:** managed complex land development entitlement review projects involving thousands of housing units and other complementary land uses. Manjeet provided innovative, creative, and strategic planning, and California Environmental Quality Act services as a consultant within both local and international professional services firms and as a representative for a large developer owner. He secured \$200 million in land purchases as part of an asset acquisition team.
- **Planner, City and County of Broomfield, City of Aurora, and City of Louisville, Denver Metropolitan Area, Colorado:** managed and negotiated development review projects, including master plans for projects from several hundred to several thousand acres in area. He conducted permit reviews for zoning compliance, inspections, and code enforcement. Manjeet also managed the public information counter and land use statistical information.
- **Project or Program Director:** responsible for the following projects:
 - Campbellton Community Investment Corridor Bus Rapid Transit, Metropolitan Atlanta Rapid Transit Authority, 2021–2022
 - Heavy Rail Station Rehabilitation and Modernization Program, Metropolitan Atlanta Rapid Transit Authority, 2021–2022
 - Bus Network Redesign, Metropolitan Atlanta Rapid Transit Authority, 2021–2022
 - Point of the Mountain Bus Rapid Transit, Utah Transit Authority, 2020–2021
 - Program Management Services, Utah Transit Authority, 2020–2021
 - FrontRunner Forward Commuter Rail Program, Utah Transit Authority, 2020–2021
 - Denison, Texas, Permit and Service Delivery: Performance Standards + Process Guide, 2020
 - Purple (D) Line Section 3 Subway, Los Angeles County Metropolitan Transportation Authority, 2017–2019
 - West Santa Ana Branch Light Rail Transit, Los Angeles County Metropolitan Transportation Authority, 2017–2019
 - Long Range Transportation Plan, Los Angeles County Metropolitan Transportation Authority, 2017–2019



MANJEET RANU

Senior Vice President, National Planning Lead

- Encinitas Housing Element, Re-zonings, Zoning Code Amendment, Design Guidelines, Local Coastal Program Amendment, Ballot Measure, Program Environmental Impact Report, 2014–2016
- Encinitas Permit and Service Delivery: Performance Standards + Process Guide, 2015
- El Cajon Deemed Approved Alcohol Retailer Zoning Ordinance, 2013
- Proposition C, City of San Diego and Carmel Valley Community Planning Board, 2010
- Otay Ranch Village 2 Sectional Planning Area Plan, Baldwin & Sons, 2010–2011
- Shell Carson Master Plan, Shell US, 2008–2009
- Otay Mesa Community Plan Update and Program Environmental Impact Report, City of San Diego, 2005–2007
- City of Aurora Municipal Center, 2002
- Industrial Development Design Standards and Guidelines, City of Louisville, 2000
- Downtown Louisville Framework Plan & Design Guidelines, City of Louisville, 1997–1999



ARON KIRSCH National Urban Development



Years with the firm

3

Years total

32

CAREER SUMMARY

Aron has 32 years of professional experience in real estate development; regional, city and state government; zoning; transportation and land use planning, including large-scale transit-oriented development projects; rail yard overbuild development and platforming; public financing mechanisms; environmental analyses; property acquisition and disposition; regional and corridor planning; build-out analyses; and business retention and attraction strategies.

He has extensive experience and success in managing the planning, design, construction and financing of large-scale transit-oriented development projects, mid and high-rise buildings (residential, office, hotel), and public infrastructure projects. Aron also has significant experience with zoning, master planning and transit agencies, such as New York City’s Metropolitan Transportation Authority (subways, Long Island Rail Road, Metro-North), New Jersey Transit, and Amtrak. He has managed a wide range of planning, design and construction projects at the regional, city, corridor and station planning levels.

Aron has worked extensively in both the private and public sectors. Most recently he served as a board member and the Senior Vice President for development and construction at a New York City-based family-owned real estate development firm, where he was responsible for all development projects and oversaw the design and construction of five large residential projects (almost 2,000 residential units) and the design of over 2 million square feet of Class A office. He brings over 20 years of public sector experience. He previously served as Senior Vice President for the Hudson Yards Development Corporation, where he oversaw the design and construction of New York City’s \$3+ billion Hudson Yards project. He is also a former city planner and project manager for the New York City Department of City Planning.

EDUCATION

MRP, Urban And Regional Planning, University of Massachusetts	1999
BA, Geography, Clark University	1995

PROFESSIONAL EXPERIENCE

- **City of Dallas Kay Bailey Hutchison Convention Center Advanced Planning, Dallas, Texas:** Project Manager responsible for overseeing the Advanced Planning phase, which includes programming, schematic development, and land use planning for the project components of the new Kay Bailey Hutchison Convention Center Dallas Master Plan. WSP began the development of the Kay Bailey Hutchison Convention Center Dallas master plan for the City of Dallas Convention and Event Services department. The vision is to transform the Kay Bailey Hutchison Convention Center Dallas into the premier convention center district in the country. The scope of work for the advance planning phase provides for programming, schematic development, and land use planning for the new Kay Bailey Hutchison Convention Center Dallas.
- **City of Dallas Kay Bailey Hutchison Convention Center Multimodal Station Master Plan, Dallas, Texas:** WSP is providing planning services to the city of Dallas to produce a master plan for facilitating and developing the Kay Bailey Hutchison Convention Center Dallas. The implementation of the master plan is projected to be a ten-year phased approach with recommendations for expanding the convention center leading to revenue-generating development. The project also involves conducting a feasibility study for developing a new multimodal transit center on the convention center properties Lots E



ARON KIRSCH

National Urban Development

and D. The existing connection was constructed in the 1930s and incorporated a railroad underpass with vehicular and pedestrian access. The existing underpass is classified as a historical structure, and WSP must consider all feasible alternatives to replacing the existing historical underpass. Numerous constraints were evaluated in the alternative design process, including existing utilities, rights of way, future railroad expansion, and water table elevation.

- **US Steel Site Redevelopment Master Plan, Chicago, Illinois:** Project Manager responsible for providing services for the master planning phase of this 500-acre project.
- **Colorado Department of Transportation 2019 On-Call Planning Services, Denver, Colorado:** Special Advisor on development and land use trends for an analysis of inland ports within Colorado. WSP is providing on-call planning services for task orders commissioned by the Colorado Department of Transportation.
- **One Central, Chicago, Illinois:** Project Director responsible for maintaining a strong client relationship and negotiating agreements with the principal-in-charge and client's executive team for this \$4 billion, P3 project. Oversight of the A/E Team, JV CMAR team pre-construction activities, and coordination with City agencies. WSP prepared the initial master plan and transportation feasibility study and has advanced the A/E design packages to 50% design development / 30% bridging documents to support ongoing P3 discussions between the client, City and State. In the next phase of the work effort, WSP will either advance the design through 100% construction documentation or become the Owner's Representative.

ONE Central is a mixed-use development project with a new multimodal transportation complex anchoring over 20 million square feet of mixed-use development, including mid-to high-rise buildings in Chicago. The project will be the first truly integrated, multi-modal transit hub in Chicago, providing unparalleled levels of mobility, featuring local, regional and national connectivity, combined with a mixed-use, Transit Oriented Development (TOD) in the heart of Chicago's civic and cultural district on the shores of Lake Michigan along Lake Shore Drive. Moreover, the project will address a number of issues facing residents and businesses within the South Side neighborhoods, as well as within the greater downtown area of Chicago and the entire regional transportation system. These issues relate to the need for additional transportation capacity and connectivity in the Chicago Central Area (Loop), more reliability in transit service for the Near South Side, visitor access to Millennium and Grant Parks, the Lakefront, the Museum Campus, Soldier Field and McCormick Place with opportunities for economic development and increased vitality.

PREVIOUS EXPERIENCE

Before joining WSP, Aron's experience included:

- **Real Estate Developer, Senior Vice President, Development and Construction, New York, New York:** led department of 10, responsible for all development projects from entitlement through completion for a family-owned development company with a property portfolio of over 20 million square feet. Aron advised the owner on development projects and opportunities by serving as a member of the Board of Directors. He oversaw design and construction of approximately 1,350 market-rate and mixed-income residential units across two projects (SKY and Oskar), delivered on time and within budget. He also



ARON KIRSCH

National Urban Development

oversaw the design of four residential buildings (1,000 units), over 2 million square feet of Class A office space, 1,000 hotel rooms, and 2 synagogues. Aron worked with the general contractor/construction manager and internal construction team to bid, negotiate, and award construction contracts, coordinate requests for information and general construction oversight. Aron collaborated with the internal finance team on land loans, development and construction financing and with the internal and external risk management team on insurance requirements and policy execution. He oversaw outside land use counsel, appraisers, and consultants, and managed external brokerage teams to market Class A office projects. In addition, Aron had full responsibility for entitlement and pre-development for all projects within the company. His duties included: - Managed entire design process from conceptual design through construction documents, including value engineering exercises - Selected and managed all project consultants and owner's representatives - Obtained any necessary DOB, City Planning and BSA permits - Negotiated and purchased air rights (Inclusionary Housing, High Line, Hudson Yards DIB, TDRs) - Negotiated with and managed design approval process with Amtrak and the Metropolitan Transportation Authority - Managed expeditors to obtain all building permits

- **Hudson Yards Development Corporation, Senior Vice President, Planning and Construction, New York, New York:** oversaw design and construction of New York City's \$3 billion Hudson Yards project, which included: Metropolitan Transportation Authority's No. 7 Subway Extension, the 2-acre Hudson Park and Boulevard, new water/sewer infrastructure and street improvements, and associated property acquisitions. Led the City's Hudson Yards project including the master plan for the Metropolitan Transportation Authority rail yard overbuild, the subway extension, the 4-acre tree-lined Hudson Park & Boulevard, the Convention Center expansion, new water and sewer infrastructure, and public financing mechanisms. Established partnerships with City Hall, Metropolitan Transportation Authority, various City and State agencies, elected officials, private developers, community boards, and neighborhood groups. Aron led the entitlement process with Amtrak, Metropolitan Transportation Authority and Port Authority, and managed architectural and engineering teams, cost estimators, construction managers and contractors.
- **New York City Planning Department, Planner/Project Manager, New York, New York:** led two major neighborhood re-zonings: Hudson Square and Hudson Yards. Led the City's Hudson Yards project including the master plan creation, the environmental impact statement, the re-zoning process, and the design of the subway extension.

PUBLICATIONS & PRESENTATIONS

Presentations

- "Infrastructure Investments: When the Private Sector takes the Lead," Rail~volution 2020, 2020



JENIFER ROSS-AMATO, JD

Sr. Vice President, Alternative Delivery



Years with the firm

2+

Years of experience

23

Education

J.D., University of Colorado School of Law, 2000

A.B., Vassar College, 1997

Professional affiliations

American Public Transportation Association Legal Services Committee; ENO Center for Transportation Transit Senior Executive Program; Multi-Agency Exchange (MAX) Program; Colorado Women's Bar Association

Areas of practice

Transit Oriented Development and Joint Development

Commercial Relationships and Governance Frameworks

Alternative Delivery Project Implementation

Stakeholder Partnering and Third-Party Agreements

CAREER SUMMARY

Jenifer Ross-Amato is a strategic, collaborative leader in infrastructure where she provides advice on planning, implementing and managing complex, innovative projects. Her expertise includes policy development, regulatory compliance, program management, procurement, contract development, commercial negotiations, stakeholder coordination, relationship management and dispute resolution. She uses a creative, solutions-focused approach to establish and maintain beneficial partnerships, negotiate resolutions and move projects forward. Prior to joining the firm, Ms. Ross-Amato led the legal team at the Regional Transportation District (RTD) in Denver as interim general counsel and deputy general counsel.

PROJECT EXPERIENCE AT WSP

- **Hudson Bergen Light Rail O&M Rebid Project, New Jersey Transit:** Project manager leading an evaluation and transition of a hand-back for a DBOM concessionaire and procurement of an operations and maintenance contractor for the light rail system, including analysis of delivery models, integration with design build project extensions, potential procurement and installation of organizational oversight team.
- **Burnham Yard Redevelopment Project, Denver, Colorado:** Deputy Project Manager serving as owner's representative for the P3 Office, State of Colorado, to prepare a NEPA-ready strategic plan to redevelop a historic freight rail yard as a transit-oriented development in the cultural heart of the city, stitching neighborhoods back together.
- **Hudson Tunnel Project, Gateway Development Program, New York City:** Assisting with development of procurement documents, geotechnical risk management strategies and Federal compliance programs. WSP is part of a joint venture providing engineering and project management for the Gateway Project.
- **California High-Speed Rail Authority (CHSRA), California:** Leading facilitation of station area planning workshops with CHSRA, City of Palmdale and multiple stakeholders to develop a partnership and governance framework to execute station master plan. WSP leads the Rail Delivery Partner consortium providing program management and planning.
- **SunRail Transition, Central Florida:** Led efforts to advise on the contracts and agreements transition process, as well as assisted with governance structure for a change of oversight of the commuter rail system by the state DOT to a separate entity comprised of multiple local jurisdictions. WSP is advising the Commission created to oversee operations of the SunRail system after the transition.
- **Capitol Region Council of Governments (CRCOG), Hartford, Connecticut:** Leading a task to evaluate and provide recommendations on the roles and responsibilities between local, regional and state public entities to implement a corridor-wide TOD program. WSP is completing a TOD implementation strategy for the region.
- **San Bernardino County Transit Authority On-Call Bus and Transit Design Services, San Bernardino, California:** Leading the task for contracts/commercial terms and third party agreements for West Valley Connector Bus Rapid Transit project. Jenifer drafts and negotiates agreements with third parties and assists SBCTA with the procurement and administration of contracts. WSP is providing program management services to SBCTA for the implementation of a new BRT service using battery electric buses in the West Valley Corridor.



JENIFER ROSS-AMATO, JD

Sr. Vice President, Alternative Delivery

-
- **Advanced Rapid Transit Projects, San Antonio, Texas:** Advised on strategy and negotiation of a partnership agreement between transit agency and city to implement a bus rapid transit project. WSP provides project management services for VIA.
 - **Maryland Purple Line Light Rail P3 Project, Baltimore, Maryland:** Advised the Program Management/Construction Management team with review and preparation of agreements and procurement documents as part of the re-solicitation for a design-build contractor. Jenifer assisted with analysis of various issues requiring renegotiation of P3 Agreement and assisted with drafting and negotiation of various third-party agreements. WSP, in joint venture, provided program management for new mass transit initiatives including the Red Line, Purple Line, Corridor Cities Transitway light rail projects.

PREVIOUS WORK EXPERIENCE

Before joining WSP, Jenifer's experience includes:

- **RTD, Denver, CO:** interim general counsel, deputy general counsel, associate general counsel; advised a 15-member publicly elected board and senior executives as well as leading the General Counsel Department (29 employees and a \$17 million budget) through transitions of CEO, General Counsel, and the Covid-19 pandemic; oversaw multiple complex procurements and transit-oriented development projects; negotiated multiple complex intergovernmental agreements and represented RTD in legislative policy efforts. Jenifer worked on numerous projects at RTD including:
 - **North Metro Commuter Rail, Denver, Colorado:** Led legal team that helped RTD stand-up its first self-operated commuter rail line – N Line – which opened in September 2020. She negotiated a \$200 million agreement with a concessionaire for shared use of the commuter rail corridor and maintenance of commuter rail vehicles; retained \$400 million railroad liability insurance; closed on right-of-way acquisitions with freight railroads; assisted in establishment of quiet zones and assisted in completing FRA New Starts matrix.
 - **Eagle P3 Project, Denver, Colorado:** Denver, Colorado: Assisted the owner of the \$2 billion Eagle Public-Private Partnership (P3) Commuter Rail Project in resolving regulatory hurdles with the Federal Railroad Administration to open the G Line in 2019 and obtain quiet zones for A, B, and G Lines; assisted with resolution of design-build project final certifications and ongoing operational administration of DBFOM concession agreement; closed on right-of-way acquisitions with freight railroads; negotiated multiple change orders and related intergovernmental agreements to deliver local TOD projects along the corridors.
 - **Denver Union Station, Denver, Colorado:** assisted RTD in implementation of joint development project for master development of station area; drafted RFP for the master development of the historic building that led to a 99-year joint development lease and millions in revenue for RTD; helped manage ongoing real property management issues, commercial agreements, intergovernmental agreements, and regulatory actions within station area including an AMTRAK lease. She also negotiated an agreement with the Downtown Denver Partnership to manage and activate public spaces near Denver Union Station, as well as easements and licenses with developers and special districts.
 - **Olde Town Transit Hub, Arvada, Colorado:** Assisted RTD in vision, development and implementation of signature TOD project along new commuter rail line through entire lifecycle of project that opened in 2019; negotiated multiple agreements that provided governance, funding and property.



NICHOLAS (NICK) FAZIO

Sr. Consultant, Land/Urban Planner



CAREER SUMMARY

Nick Fazio has experience as a multidisciplinary consultant in the fields of community planning, urban design, parks and recreation, and public policy. His skills as a designer, planner, and community organizer enable him to effectively solve problems and communicate complex ideas to diverse audiences. Nick's background includes comprehensive planning, strategic planning and policy analysis, long-range planning and historic preservation. Nick has worked in both urban and rural settings with public and private stakeholders, and always strives to create quality places that meet the clients' needs and serve the local community.

EDUCATION

MS, Colorado State University, 2014

Years with the firm

3

Years total

14

Other languages

Spanish

PROFESSIONAL MEMBERSHIPS

American Planning Association: Professional Development & Continuing Education Co-Chair

PROFESSIONAL EXPERIENCE

- **Port of Morrow 2020 Strategic Business Plan Update, Boardman, Oregon:** planner responsible for public outreach summaries, including stakeholder interviews and the strengths, weaknesses, opportunities, and threats analysis; data collection; and production of the draft and final strategic business plan documents for the Port of Morrow. WSP to update the strategic business plan for the Port.
- **Tryon Creek Trunk Sewer Upgrade, Portland, Oregon:** planner working with the City of Portland's Bureau of Environmental Services to provide public involvement and outreach services. Project responsibilities include initial key stakeholder outreach, project-related stakeholder interviews, and team coordination. WSP provided design services for the assessment and maintenance upgrades of a 800 linear foot elevated concrete sewer pipe from the Tryon Creek Wastewater Treatment Plant in Lake Oswego.
- **City of La Center 2020 On-Call Planning Services, La Center, Washington:** planner responsible for supporting the City of La Center with land use application review and staff recommendations to ensure consistency with the La Center Municipal Code and state law. The work includes coordination with City staff and applicants, writing staff reports, and planning commission and City council presentations. WSP is providing on-call planning services to the City of La Center as a subcontractor to E2 Land Use Planning Services. Work will include staffing the planning counter on site and conducting permit reviews.
- **City of Vancouver Southeast 18th Street Improvements, Vancouver, Washington:** planner responsible for environmental review in accordance with the State Environmental Policy Act for a proposed street extension in Vancouver, Washington. Project work includes evaluation of environmental impacts for compliance with local and state law. WSP provided environmental resource documentation and federal, state, and local permitting services for this federally funded corridor completion project that will upgrade and extend NE 18th Street between NE 97th Avenue and NE 107th Avenue, with three roundabouts, for the City of Vancouver. WSP's environmental team was tasked with



NICHOLAS (NICK) FAZIO

Sr. Consultant, Land/Urban Planner

developing environmental documentation and securing environmental permits. WSP prepared a NEPA CE form and associated discipline documents, a no effect letter for Endangered Species Act consultation, SEPA checklist and a critical areas report. AINW conducted an archaeological investigation to comply with Section 106 and NEPA.

- **Curtin Creek Community Park, Vancouver, Washington:** planner responsible for public involvement and outreach for a proposed community park in unincorporated Clark County, Washington. Project responsibilities include stakeholder outreach, project-related event planning and assistance, survey development and analysis, and team coordination.
- **Providence Academy/Aegis Phase II, Vancouver, Washington:** planner responsible for public involvement and outreach for the redevelopment of a historic property in downtown Vancouver into a mixed-use development. Project responsibilities include stakeholder outreach, project-related event planning and assistance, technical analysis, and team coordination.
- **State Route 500, Northeast Lake Road and Northeast Everett Street Intersection Improvements, Camas, Washington:** planner responsible for public involvement and outreach related to an intersection improvement project. Project responsibilities include stakeholder outreach, project-related event planning and assistance, content development and writing, and team coordination. WSP is responsible for leading the structural engineering, environmental permitting and documentation, and public outreach services as part of a project team for the NE Everett Road (State Route 500) and NE Lake Road intersection improvement project connecting the north shore, south shore, and downtown Camas and providing access to regional recreation areas at Lacamas Lake and Round Lake.
- **Buildable Land Needs ASES & HAP, Stevenson, Washington:** planner responsible for public involvement and outreach related to identifying buildable lands and development of a housing needs analysis in a rural Skamania County. Project responsibilities include public outreach, project-related stakeholder interviews, technical analysis of housing needs and related technical writing, and team coordination.
- **White Salmon 2021 Comprehensive Plan Update, White Salmon, Washington:** planner responsible for assisting with the comprehensive plan update for the City of White Salmon. Responsibilities include review and analysis of the current comprehensive plan, development and technical writing of comprehensive plan chapters, and team coordination. WSP is updating the City's comprehensive plan.

OTHER WSP EXPERIENCE

- **Irvine Access Floors, Laurel, Maryland:** construction foreman responsible for a leadership role in this company for six years. Managed a crew from two to 15 people. Completed all jobs according to specification, codes, and blueprints. Work ranged from initiating new projects to fixing previous construction. For the largest project he installed 100,000-square feet of flooring, using metal tiles, at the National Security Agency. Safely operated forklifts.
- **City of Baltimore Consent Decree Program Management SC 903, Baltimore, Maryland:** inspector I for the 102,000 linear feet of cured-in-place pipe lining; 5,800 linear feet of cleaning and closed-circuit television of pipe; 1,700 linear feet of replacement of sanitary sewer by open cut method; rehabilitations of 1,500 sanitary house connections; rehabilitation of 370 existing sanitary sewer with new sanitary sewer manholes; and 370



NICHOLAS (NICK) FAZIO

Sr. Consultant, Land/Urban Planner

vertical linear feed of replacement of sanitary sewer manholes. Included associated wastewater bypass pumping of control of flows of sewer and/or manholes to be repaired, replaces, constructed or rehabilitated and continuous monitoring of the bypass operation. Restoration of pavement, alleys, and sidewalk and site restoration, including planting trees.

- **City of Baltimore, Consent Decree Program Management SC 920, Baltimore, Maryland:** inspector I for the 110,000-feet of cured-in-place (CIPP) lining; 6,600-feet of sewer cleaning and closed circuit television inspection; 4,130-linear feet of replacement of sanitary sewers by open cut method; 110 sanitary sewer open cut repairs; 143 sanitary sewer point repairs and 288 sewer house connections repairs using CIPP; 1,332 rehabilitations of sanitary house connections by grouting; 1,446 vertical feet of interior coating sanitary sewer manholes; 567 vertical linear feet of replacement of existing sanitary sewer with new sanitary sewer manholes; associated wastewater bypass pumping and control of flows of sewer and manholes to be repaired, replaced, constructed or rehabilitated and continuous monitoring of the bypass operation; and restoration of pavement, alleys, sidewalks, fences, and site restoration. Responsible for post cleaning closed-circuit television/SONOR assessment to document the internal condition of the pipes per Pipeline Assessments and Certifications Program protocols. Manhole inspections in accordance with the manhole assessment and certification programs protocols. Providing inspection services to include: review of contract documents and inspection for conformance. Responsible for field correspondence and memos, safety compliance assurance, daily reports, material logs, delivery tickets, and attendance at progress meetings.
- **City of Baltimore, Consent Decree Program Management SC 922R Large Diameter Sewer Cleaning, Low-Level Sewer Sheds, Baltimore, Maryland:** inspector I for the project included the cleaning of 12,030-linear foot of 24-inch to 64-inch sanitary sewers from Highland Avenue to the Eastern Avenue Pump Station for the Eastern Interceptor; 10,941-linear feet of 51-inch to 84-inch sanitary sewer from Warner Street to the Eastern Avenue Pump Station for the Western Interceptor; and the Eastern Avenue Pump Station grit chamber, with proper disposal of removed material, post cleaning closed-circuit television/SONOR assessment to document the internal condition of the pipes per Pipeline Assessments and Certifications Program protocols. Included manhole inspections in accordance with the manhole assessment and certification programs protocols. Provided inspection services including: review of contract documents and inspection for conformance. Responsible for field correspondence and memos, safety compliance assurance, daily reports, material logs and delivery tickets, and attendance at progress meetings.
- **Complete Streets Ordinance and Program, Castle Rock, Washington:** planner and deputy project manager responsible for assisting the City of Castle Rock with development of a Complete Streets ordinance and program. As the first community to envision and adopt a Complete Streets program in the county, Castle Rock took a leadership role in community-based planning and pedestrian infrastructure prioritization. Responsibilities included public outreach and engagement, management and facilitation of a citizen's working group, technical analysis and writing of the ordinance, program design, and management of the docketing and adoption process. Castle Rock's program is considered highly successful and led to the acquisition of competitive Complete Streets grant funds in its inaugural year.
- **Comprehensive Plan Map Amendments and Zone Changes, West Richland, Washington:** planner assisting with amendments to the City of West Richland comprehensive plan map and associated rezoning of three parcels in the City's fast-



DANIEL BAER, AICP , Senior VP
National Planning Marketing Lead



CAREER SUMMARY

Daniel Baer is experienced in managing large, multidisciplinary teams for transportation and land development initiatives, alternatives analyses and master plans for major transportation and site development projects. He has managed the preparation of hundreds of major transportation projects, feasibility studies, alternatives analyses and environmental assessment programs. He has led and organized a variety of Transportation Oriented Development (TOD) and large/complex overbuild projects, including the preparation of design guidelines and funding/financial strategies.

Years with the firm

17

Years total

39

Professional registrations

Certified Planner (AICP): US

EDUCATION

MUP, Planning, New York University	1984
BA, Public Policy, Pomona College	1981

PROFESSIONAL MEMBERSHIPS

- American Planning Association
- Urban Land Institute

PROFESSIONAL EXPERIENCE

Burnham Yard Redevelopment Project, Denver, Colorado: Project Manager serving as owner’s representative for the P3 Office, State of Colorado, to prepare a market driven strategic redevelopment plan for one of the City of Denver’s last large development parcels. The project will result in the transformation of a historic freight rail yard to a transit-oriented development in the cultural heart of the city, stitching neighborhoods back together. The project will also involve the identification of a preferred rail relocation strategy that will allow for the greatest possible generation of value for the residual property. The project also involves the identification of a locally preferred alternative for the rail infrastructure which will be advanced through the NEPA process.

Hudson Yards Development Corporation (HYDC) Hudson Yards-Eastern and Western Rail Yards Master Plan and Design Guidelines, New York City, New York: project manager responsible for managing the development of a master plan and engineering and planning/design guidelines for the construction of over 12 million square feet of mixed use development and open space over the West Side Storage Yard. The final product was an extensive set of design guidelines allowing for the development of up to twelve million square feet of office and hotel space; three million square feet of residential space; 200,000 square feet of retail space; parking facilities; a new major cultural facility; and approximately five acres of open space over an operating rail yard. The project represents one of the first major TOD over an active rail yard that was financed through a value capture mechanism associated with a rezoning action along the west side of midtown Manhattan. (2005-2008)

Port Authority Bus Terminal Replacement Program, Master Plan, design and environmental assessment, New York, New York: Deputy project manager for transportation planning, operations, environmental analysis and facilities alternative development and analyses. WSP was selected to provide planning and environmental services for replacing The Port Authority of New York and New Jersey’s Midtown Manhattan bus terminal—the world’s busiest bus depot serving 232,000 customers daily with use expected to increase 40 percent by 2040. Services include identifying a location for a new terminal and reviewing the Authority’s previous Midtown Bus Master Planning, the Trans-Hudson Commuting Capacity Study, concepts submitted to the Terminal International Design +



Deliverability Competition and the build-in-place option which keeps the terminal operating while a fifth and sixth floor are added prior to rebuilding the existing four floors. (2017-ongoing)

Kay Bailey Hutchison Convention Center (KBHCC) and Multi-Modal Master Plan, Dallas, Texas: Project Manager for the preparation of four distinct master plans that will guide the selection of a preferred Convention center and new multi-modal station alternative. The selected KBHCC will provide the appropriate amount of conference room and exhibit space to recapture portions of the convention center market it has lost to other large facilities. The Multi-modal station will serve a number of purposes. Primarily, it will serve new and emerging commercial and retail markets. Secondly it will provide access to hotels and the convention center and, will be a catalyst for new growth and increased value. A phased implementation plan will be prepared which identifies the potential funding/financing opportunities which include improvement districts, value capture, FTA grants and other sources. (2020-2023)

National Western Stockshow site Master Plan, Denver, Colorado: Technical advisor for the development of criteria and the process to evaluate the multiple development options for the site. Working with the project manager, developed a range of criteria that would appeal to the diverse range of stakeholders that either operated the site, local transit, or the community that lived adjacent to the site. (2013-2015)

Confidential Client-Private Developer, Chicago Illinois, Project Manager for the preparation of a feasibility study and master plan for a new multimodal transit center to be constructed over and active METRA yard, located near the Southside of Chicago. The proposed station would consist of 6 million ft² of customer related uses and would accommodate the potential for an additional 17 million ft² of new mixed-use development over an active METRA yard. The new multi-modal station would accommodate METRA service, a new premium bus service (BRT) and in the future CTA and AMTRAK service. The project would be one of the most utilized stations in Chicago and one of the largest TOD projects in the country, and would provide significant transportation, economic and environmental benefits. (2019-ongoing)

Redevelopment of White Plains Transit Center Master Plan, White Plains, New York: project manager responsible for oversight of redevelopment plan. WSP provided the City of White Plains, New York with preliminary planning, design and engineering services for a proposed redevelopment of White Plains Station and downtown area to create a gateway into the City of White Plains, maximizing economic development potential, and creating linkage to downtown. (2015-2017)

Sunnyside Yards Overbuild Feasibility Study, Queens, New York: Project Manager for the development of the transportation plan and site overbuild of an active rail yard along the Northeast Corridor. Sunnyside Yards presently accommodates three different operating railroads with varying temporal characteristics. The proposed project would result in the construction of over 10 million square feet of new mixed-use space in an actively developing portion of Queens. (2014-2016)

Staten Island North Shore Land Use Study/Master Plan, New York, New York: project manager responsible for the preparation of a comprehensive land-use transportation plan for the North Shore area of Staten Island, which extends from St. George to Elm Park. The North Shore area has experienced losses in commercial and retail sales and base and is saddled with significant levels of vehicle congestion along its major east-west roadways. This plan of action provides a framework for the implementation of immediate and long-term initiatives that focus on revitalizing and opening up the North Shore waterfront and important commercial corridors and residential areas. (2008-2010)

New Jersey Sports and Exposition Authority Sports Complex Master Plan, New Jersey: project manager for the investigation and assessment of environmental and transportation opportunities and constraints associated with locating new entertainment and recreational facilities at the existing sports complex in Hackensack Meadowlands District. He also investigated on-site modifications to



DANIEL BAER, AICP , Senior VP
National Planning Marketing Lead

improve access and circulation between existing and proposed facilities. His duties included analyzing rail access to the complex with several design concepts prepared, each enabling regional access to the site. Constraints to development included wetlands and hazardous materials. (2003-2007)

New York Jets Development West Side Sports and Convention Center, New York City, New York: project manager for the preparation of the traffic, parking and transportation analysis for a new West Side football stadium and convention center complex. The new stadium would be incorporated into an expanded Jacob Javits Convention Center and converted to convention center space on non-football event days. The analysis addressed conditions before and after a football game and potential impacts associated with traffic, pedestrian circulation, parking and transit accessibility.(2001-2003)

AWARDS

Diamond Award for Cross Harbor Freight Movement EIS, American Council of Engineering Companies

Winner of the International Design Competition for the West Side of Manhattan
Prepared traffic and transit analysis and design

Honorable Mention for East Corridor Regional Rail Project, Nashville,
Tennessee, New York Association of Consulting Engineers

Gold Award for the Northern Corridor Alignment Study, Orlando, Florida,
NYACE

PUBLICATIONS & PRESENTATIONS

Presentations

- “Land Use and Transportation,” Charlotte North Carolina Chamber of Commerce, in conjunction with ULI
- “Visiting Lecturer, Environmental Planning Seminar,” New York University, Wagner School, NY, 1993-2002
- “Stadium Siting Decisions,” APA, 1994
- “Transportation and Stadium Operations,” APA Conference, 1996-1997
- “Visiting Lecturer, Urban Infrastructure Workshop,” New Jersey Institute of Technology, NJ, 1997-1998
- “Light Rail Transit,” The Orlando Experience, APTA Conference, 2003



MARK MONTGOMERY

Senior Vice President



CAREER SUMMARY

Mr. Mark Montgomery is a graduate of Kansas State University in architectural engineering. He is currently the Buildings Practice Denver office manager, as well as in charge of overseeing the operations for WSP’s Denver, Boulder, and Kansas City offices. His duties include regional strategy, office management, business development, and electrical engineering. Mr. Montgomery has over 19 years of experience at the firm and has been involved in the design of a variety of different projects, including hospital facilities, institutional facilities, laboratory facilities, corporate facilities, and data centers. Mr. Montgomery has been honored with CSE Magazine’s top 40 under 40 award in 2011, as well as his company’s “Engineer of the Year” award given in 2004.

SELECTED PROFESSIONAL EXPERIENCE

Campus & District Master Planning experience

- Rice University, Brockman Hall for Physics, Houston, Texas
- Virginia Commonwealth University Health System, Service Consolidation, Richmond, Virginia
- Graham County Hospital Expansion Study, Hill City, Kansas
- PSL Energy Master Planning, Denver, Colorado
- PSL Campus Plant Consolidation, Denver, Colorado
- Northern Arizona Healthcare Fort Tuthill Medical Center, Flagstaff, Arizona
- Medical Center of Aurora – Expansion Study, Aurora, Colorado
- Banner Fort Collins Medical Center, Fort Collins, Colorado
- Centura Interquest Master Planning Engineering Support, Colorado Springs, Colorado
- North Colorado Med Center Electrical Systems Upgrades, Greeley, Colorado
- Uintah Base Medical Center Master Plan, Vernal, Utah
- Aiken Regional Medical Center, Master Plan, Aiken, South Carolina
- Castle Rock Adventist, Health Center Campus Master Plan, Castle Rock, Colorado
- Medical Center of Virginia (VCUHS), Heart Center, Richmond, Virginia
- Medical Center of Virginia (VCUHS), Interventional Radiology Suite, Richmond, Virginia
- Winchester Medical Center, Master Plan, Winchester, Virginia

Years with firm

25

Years of experience

25

Professional registrations

CO, MO, VA, UT, WY, NV

Education

BS, Architectural Engineering, Kansas State University

Professional memberships

ASHE, CAHED, I2SL, ISPE, IESNA, USGBC

Awards

CSE Magazine’s top 40 under 40 award in 2011

Languages

English



JENNIFER HYRE

Assistant Vice President, Environmental Planning



CAREER SUMMARY

Jennifer brings over 20 years of experience in multi-disciplinary environmental compliance, permitting, and mitigation needs for local government, public works, transportation, and land development projects. Prior to joining WSP, she was an Environmental Analyst with the NMDOT Environmental Bureau. She has extensive experience with high-profile Public Involvement, environmental clearances, and cultural resources management. She regularly serves as a project development team member during Phase I-A, I-B, I-C, and I-D and has a thorough understanding of the Location Study Procedures. Jennifer currently manages three on-call contracts with the NMDOT Environmental Bureau.

SELECTED PROFESSIONAL EXPERIENCE

Years with the firm

5

Years total

22

Education

*Master's Certificate,
NEPA, Utah State
University*

*BS, Environmental
Science Juniata College*

Professional registrations

*Wetland Delineator
Certification: NM*

Areas of Practice

Alternatives Development

*NEPA Environmental
Assessments and
Categorical Exclusions*

*Public and Stakeholder
Engagement*

*Federal Agency
Consultations*

Wetland Delineations

*Clean Water Act 404/401
Permitting*

Biological Assessments

*Archaeological and Historic
Properties Section 106
Compliance*

- **NMDOT Environmental On-Call, NEPA Public Involvement Guide, Statewide, New Mexico:** Jennifer is the Project Manager and Public Involvement Lead for a task order under WSP's on-call environmental contract with the NMDOT Environmental Bureau which included development of the Department's first ever Guide to Public Involvement. Future support will include producing training materials on how to use the guide.
- **NMDOT NM 500 Rio Bravo Bridge Replacement, Albuquerque, New Mexico:** Jennifer is the Environmental and Public Involvement Lead for a critical project replacing the four bridges over the Rio Grande in Albuquerque's South Valley. WSP completed the Phase I-A/B study report and alternatives screening and is currently performing Phase I-C and I-D services. Jennifer is leading the team of specialists performing the biological assessment, wetland delineation, historic properties investigation, noise study, and visual impact assessment. Key environmental resource considerations include the Rio Grande, irrigation canals, protected species and critical habitats, bats, right-of-way constraints, and floodplains. WSP has led all public involvement for this project, including live virtual public meetings using Zoom Webinar. To aid in garnering public interaction, a customized MetroQuest online survey platform was developed, which received over 300 comments. All materials including the live presentation were provided in English and Spanish. Throughout the project, Jennifer has facilitated proactive engagement with the multiple federal and state stakeholder agencies having jurisdictional or regulatory authority within proximity to the project.
- **NMDOT NM 6 Bridge Replacement, Los Lunas, New Mexico:** Jennifer served as the Environmental Lead. WSP completed the evaluation of alternatives, preliminary design, environmental investigations, final design, and provided construction services for the NM 6 Bridge replacement over the Rio Grande. Key concerns included impacts to the river and floodplains, bats, waterfowl refuges, historic sites (FHWA Section 4(f)), protected species, critical habitats, span arrangement, construction phasing, and ROW impacts. Jennifer facilitated Section 7 Endangered Species Act consultations and development of mitigation measures in addition to preparing the Categorical Exclusion.
- **NMDOT NM 599 and Via Veteranos Intersection, Santa Fe, New Mexico:** Jennifer provided staff augmentation public involvement support for an intersection access control project being developed by the NMDOT. She prepared and distributed meeting notices, facilitated and mediated an in-person public meeting with numerous disruptive and highly engaged people, and prepared an input synopsis summarizing the agency's cumulative public involvement efforts on the project.



RAYMOND TRUJILLO, PE

Vice President, Structural Engineer



CAREER SUMMARY

Ray Trujillo is the senior bridge/structures manager for WSP’s New Mexico operations. He has nearly three decades of experience in bridge, structural, drainage, and highway design. Prior to joining WSP, Ray spent 20 years as a bridge design engineer and as the state bridge engineer for the New Mexico Department of Transportation. As the state bridge engineer, Ray oversaw the New Mexico Department of Transportation's Bridge and Structures Program, which includes the design, management, maintenance, and inspection of bridges and structures to ensure bridges were safe for public use. Under his leadership, the New Mexico Department of Transportation’s Bridge Program in 2016 ranked fourth in the nation in least amount of structurally deficient and functionally obsolete bridges. During his tenure with WSP and New Mexico Department of Transportation, Ray has worked on over 600 bridges in New Mexico, involving new bridges, bridge replacements, rehabilitation, and preventive maintenance.

Years with the firm

5

Years total

31

Professional registrations

*Professional Engineer:
NM (13514); NV (26106)*

Areas of practice

Bridge Design

*Construction
Management*

Drainage Design

Highway Design

EDUCATION

BS, Civil Engineering, New Mexico State University, 1992

PROFESSIONAL EXPERIENCE

— **New Mexico Department of Transportation Statewide Bridge Services, Various Locations, New Mexico:** WSP is providing engineering services for a series of bridge projects throughout the State of New Mexico.

- **AASHTO Manual for Assessing Safety Hardware (MASH) Bridge Rail Literature Review, Various Locations, New Mexico:** provided a quality control review of the literature review document on this project. WSP provided engineering services for a literature review for the nationwide research of American Association of State Highway and Transportation Officials Manual for Assessing Safety Hardware (MASH)-compliant railing.

OTHER WSP EXPERIENCE

- **Clark County - Laughlin-Bullhead City Bridge over the Colorado River, Clark County, Nevada:** design engineer for a new 724-foot bridge spanning the Colorado River. The maximum span was 168 feet. The superstructure consisted of California WF-84 prestressed concrete girders with a cast-in-place deck and integral piers. The bridge carries four drive lanes, as well as a multi-user pathway.
- **Nevada Department of Transportation - Statewide Load Rating (Task 2), Nevada:** served as the project manager for load rating and calculations of 120 bridges under Emergency Vehicles (EV2/EV3). The bridges included steel culverts, concrete culverts, concrete girders, and steel plate girders performed using MDX, BRASS-GIRDER, BRASS-CULVERT, and CANDE.
- **New Mexico Department of Transportation - Interstate 10 over Main Street Bridges 9836 and 9837 Replacement, Lordsburg, New Mexico:** responsible for load rating, quantity calculations, cost estimate, and quality control review of plans for conformance with New Mexico Department of Transportation standards. Ray designed and detailed 35-foot approach slabs. He also performed independent prestressed girder design, as well as bridge load rating using AASHTOWare Br R.



RAYMOND TRUJILLO, PE

Vice President, Structural Engineer

- **New Mexico Department of Transportation - New Mexico Highway 96 over Rio Puerco Bridge Replacement, New Mexico:** served as a bridge engineer responsible for performing quantity calculations, cost estimate, and checking bridge plans for conformance with New Mexico Department of Transportation standards. Ray designed and detailed bridge deck, abutment caps, approach slabs, and steel girders. He also performed bridge load rating using AASHTOWare Br R.

PREVIOUS EXPERIENCE

Before joining WSP, Raymond's experience included:

- **New Mexico Department of Transportation - Bridge Bureau Chief, New Mexico:** as the Bridge Bureau Chief, Ray was responsible for managing and overseeing New Mexico's Bridge and Structures Program, which included managing the Bridge Design Section and the Bridge Management Section within the Bridge Bureau. Ray's duties included managing staff and project schedules in support of the New Mexico Statewide Transportation Improvement Program; providing input into the project planning process and assisting in the selection of bridges that needed maintenance, rehabilitation, or replacement; designing cost effective, durable, functional, and safe bridges and structures for highway projects; incorporating best practices into the design of bridges and structures; ensuring quality assurance/quality control was carried out on each individual project; providing technical support during construction of bridges and structures; managing and administering multiple contracts and assigned tasks to consultants and universities; providing technical support to the District offices and Rail Bureau on bridges and structures; ensuring all District offices were on-time with bridge inspections per the National Bridge Inspection Standards; providing training opportunities for internal staff and bridge engineer consultants; evaluating fabricators and product suppliers for their capability in performing work for the New Mexico Department of Transportation; providing proactive participation in all human resource issues and budget matters; and responding to all agency, legislative, contractor, or public requests pertaining to elements managed or determined to be under the jurisdiction of the New Mexico Department of Transportation Bridge Bureau.
- **New Mexico Department of Transportation - Bridge Design Unit Leader, New Mexico:** as the Bridge Design Unit Lead, Ray's duties included preparing bridge plans and performing design calculations in conformance with the New Mexico Department of Transportation's design policy and procedures; providing cost effective, functional, durable, and safe bridge/structural designs; designing steel girder, reinforced concrete slab, and prestressed concrete girder bridges; participating in design team meetings to meet the goals of the project; performing thorough reviews and checks of consultant's reports, details, and construction plans and recommending alternative structural designs; providing technical support to construction personnel and performing construction inspections during construction of bridges and major structures; preparing scoping reports and cost estimates for bridge and major structure projects; checking fabricator's shop drawings during construction for compliance with the contract plan details; assigning tasks to engineers/engineer technicians in order to meet on-going deadlines; working with the New Mexico Department of Transportation's Drainage Section and the U.S. Geological Survey to analyze bridges for scour and stability; determining inventory and operating rating capacities for existing and new bridge structures; and attending and presenting at various bridge conferences around the nation on the New Mexico Department of Transportation's successful Accelerated Bridge Construction projects.



- **New Mexico Department of Transportation - Selected Projects, New Mexico:** Ray worked on several projects throughout his tenure with the New Mexico Department of Transportation, including: - Mountain Valley Road over Interstate 40, Edgewood, New Mexico: engineer of record responsible for the design of a new two-span prestressed concrete box girder bridge on concrete abutment walls and concrete pier columns on spread footings (Bridge #9303). The bridge was built in 32-calendar days, making it a successful accelerated bridge construction project. Ray provided technical support during construction to ensure its success. - New Mexico 63 over Glorieta Creek, Pecos, New Mexico: engineer of record responsible for the design and detailing of a single-span rolled steel girder bridge on drilled shafts (Bridge #8888), as well as the design and detailing retaining walls for earth and roadway support. Ray provided technical support during construction. - U.S. Route 491 Northbound over Tocito Wash, Little Water, New Mexico: engineer of record responsible for the design of a new seven-span reinforced concrete slab bridge on drilled shafts (Bridge #9337). Ray provided technical support during construction. - U.S. Route 64 over Amargo River, Dulce, New Mexico: engineer of record responsible for the design of a new two-span prestressed girder bridge on driven piles (Bridge #9371). Ray designed soldier pile wall, moment slab, and geofoam block fill for roadway portion experiencing settlement issues due to thick underlying plastic clay layer near Bridge #9371. He also provided technical support during construction. - U.S. Route 491 Northbound over Sanostee Wash, Little Water, New Mexico: engineer of record responsible for the design of a new two-span prestressed girder bridge on drilled shafts (Bridge #9338). Ray provided technical support during construction. - U.S. 64 over Amargo Creek, Amargo, New Mexico: engineer of record responsible for the design of a new single-span prestressed girder bridge on drilled shafts (Bridge #9387). Ray provided technical support during construction, which included responding to request for information and reviewing shop drawings for construction. - U.S. Route 491 Northbound over Pena Blanca Arroyo, North of Newcomb, New Mexico: engineer of record responsible for the design of a new single-span prestressed girder bridge on drilled shafts (Bridge #9339). Ray provided technical support during construction. - New Mexico 456 over Sloan Creek, Northeast Corner of New Mexico near Oklahoma Border: engineer of record responsible for the design and detailing of full height concrete abutment walls and wingwalls on spread footings for a steel thru-truss bridge (Bridge #9291 - Mabey Bridge). Ray provided technical support during construction.



PETER WALDT

Director, Commercial Planning & Development



Years with the firm

2.5

Years of experience

41

Education

University of Rochester
M.S., Public Policy Analysis
(Quantitative Analysis and
Economic Development), 1983;
B.A., American History (Early
American Economic History),
1978

Professional affiliations

Region Plan Association: Member
New Jersey Council 2012-present

Areas of practice

Advisory Services: Commercial
Aspects of Projects, Asset
Monetization, Financial
Architecture to allow Value
Capture

ADVISORY CAREER SUMMARY

Peter Waldt is Senior Vice President with WSP USA Advisory Services. He leads WSP's efforts in Value Capture and Real Estate Transactions. He has significant experience in asset monetization and Transit Oriented Development transactions, particularly in creating the financial architecture of a project and land value capture. Further, he has lengthy experience in commercial lending and real estate finance, notably **over 30 stadiums and arenas**. Among current clients are:

WMATA – various station real estate analyses and development solicitation documents

Broward Commuter Rail South - Land Use and Economic Development Study,

Determine TOD & Value Capture potential, including market demand, site assessment & developer interviews, Ft. Lauderdale-Hollywood, FL

Ft. Worth East Lancaster East Corridor & Subregional Study, Determine eTOD potential, including gentrification susceptibility, site assessment & developer interviews, Ft. Worth, TX

Houston Metro Inner Katy Joint Development & TOD Assessment, Identify & quantify opportunities for joint development & TOD at proposed Inner Katy BRT Station, Houston, TX

Connecticut DOT (CTDOT), Downtown New Britain CTfastrak Station Development Request for Expressions of Interest, New Britain, CT

Capitol Region Council of Governments (CRCOG), TOD Roles, Visioning, Viability & Tools Analysis Study, including site selection, program creation financial feasibility & developer interviews. Hartford, CT

Missouri DOT, Methods for Increasing Missouri's Passenger Rail Business via asset monetization.

Uptown Consortium, Inc (UCI), Cincinnati, OH large-scale, mixed-use development funding and financing strategies

Amtrak Gateway Program, New York, NY, valuation of developments rights for Build America Bureau Funding.

PREVIOUS EXPERIENCE

Amtrak, Philadelphia, PA: Peter was Senior Director of Commercial Planning and Development who led a dynamic team of 15 professionals responsible for all of Amtrak's non-fare revenue generation and Major Station Redevelopment transactions, including Sunnyside Yard, Chicago, Baltimore, Philadelphia, New York, and Washington, DC as well as land acquisition for the Gateway Program. Peter's team increased revenue from \$79 enhancing revenue generation opportunities of Metrolinx' current and expected landholdings, Waterfront Toronto: development of the 1,000-acre Port Lands site, JP Morgan Asset Management, Sun Edison, CAN DO (Hazleton, PA), BNSF, Seattle air rights disposition Noisette (Charleston, SC), CIBA (Toms River, NJ), Darien Conservation Park (Panama), Harrisburg Redevelopment Authority, The Greater Wilkes-Barre Chamber, the City of Rochester, Aquatic Park Science Park (Berkeley, CA), the Puerto Rico Science, Research & Technology Trust, Toronto Transit Commission and Wilkes University.

New York Metropolitan Transportation Authority, New York, NY: Peter was Director of Real Estate development who directed all of the MTA’s real estate development efforts and reported to the Director of Real Estate. Peter was responsible for creating and locating opportunities that would generate revenue from the MTA’s assets. He was the go-to person for developers, enabling them to successfully interact with the MTA on several levels. He created a transit-oriented development (TOD) program that generated additional ridership with no further demand on existing parking facilities; created an advisory committee made up of developers, brokers, and corporate real estate executives to craft the TOD program in Nassau and Suffolk counties, engaging executives in the towns and counties to make this a bottom-up effort; initiated a corporate sponsorship program allowing corporations to partner and align themselves with the MTA; and was **responsible for negotiating air rights lease terms of the NY Jets for the West Side Rail Yard/Stadium project and Forrest City Ratner/Atlantic Yards project including Barclays Arena.**

Empire State Development Corporation/UDC, New York, NY: He was Vice President of commercial lending and real estate finance/project finance, who reported to the Chief Financial Officer and the Senior Vice President of Loans & Grants with five direct reports. Peter was responsible for underwriting and negotiating terms for all Empire State Development (ESD) projects, loans, and discretionary grants ranging from \$50,000 Small Business Administration (SBA) type lending to a bond funded \$127 million sports facility program. He was responsible for underwriting NYS’s investment in university sponsored incubators including the State University of New York (SUNY) Stony Brook, Farmingdale, Albany (including Nano Technology Center), Buffalo, Alfred-Corning, Rochester Institute of Technology, University of Rochester, Columbia University, Mohawk Valley, and Syracuse University. He moved long-dormant properties, like the New York Coliseum and Harlem landmark sites into development stimulating billions of dollars of private investment. He directed the corporation’s Special Project Finance including the NYC 2012 Olympic Bid. He authored RFPs and managed consultant contracts for the Downtown Commuter Rail Economic Impact Study, Penn Station Feasibility Study (which led to the creation of the Moynihan Station Development Corporation), **Yankee Stadium Site Selection Study, Shea Stadium Replacement Analysis**, and Hunterspoint Development Feasibility Study (which led to the creation of the Queens West Development Corporation). **He also underwrote financing for and managed the pre-development of 29 sports and spectator facilities, including Yankee Stadium, Shea Stadium, and HSBC Arena (Buffalo) and wrote the financial plans for the Penn Station Redevelopment Plan, the Javits Convention Center, and the Hudson River Park.**

TEACHING EXPERIENCE

Guest Lecturer/Founder, Affordable Housing Design Studio New Jersey School of Architecture/NJIT: 2010-2016, Newark Penn Station Master Plan Advisor: 2021

Lecturer, Real Estate Development Program, Columbia University Graduate School of Architecture, Planning & Preservation: 2000, 2009

Visiting Professor, **Arena and Stadium Finance**, New York University Summer Institute: 1996-1998



TIMOTHY THORNTON

Principal Consultant



Years with the firm

12

Years total

23

Areas of practice

Real estate financial and market feasibility, fiscal and economic impacts, financial analysis and funding options and optimal land use decision making.

CAREER SUMMARY

Tim Thornton is an economic, market and financial consultant with experience providing solutions for public and private sector clients with questions involving real estate financial and market feasibility, fiscal and economic impacts, financial analysis and funding options and optimal land use decision making. Mr. Thornton has many years of experience as a consultant to public sector clients ranging from local governments; housing authorities; state and local transportation agencies; federal development authorities; and private sector clients including developers, financial institutions and non-developer landowners. Mr. Thornton has conducted real estate validation and analysis for municipalities, public transportation agencies and private clients across the county; including his work with the City of Newport News where he analyzed the market feasibility of residential land uses in a variety of densities and formats, from multifamily apartments and condominiums to townhomes, as well as non-residential uses including office and hotel. The analysis also factored in the interrelationship between certain land use mixes and their impacts on parking and other factors (e.g. daytime users vs. nighttime users of various uses). The market-driven findings and recommendations helped the City understand the best land use plan for the site and shed light on the development's revenue generating potential that could be channeled to the station costs. Prior to joining WSP, he worked for the U.S. Department of Housing and Urban Development (HUD), Morgan Stanley investment advisors, and two leading urban economics firms in the greater DC area.

EDUCATION

MBA, Business Administration, Rice University, 2004

BA, Economics & Business, Lafayette College, 1998

PROFESSIONAL MEMBERSHIPS

Urban Land Institute

PROFESSIONAL EXPERIENCE

- **Loudoun County Zoning Ordinance Update On-Call, Loudoun County, Virginia:** developed the funding and financing strategies to increase affordable housing supply as part of the county's Unmet Housing Needs Strategic Plan. Following a comprehensive review of the county's existing tools and mechanisms, the team conducted interviews and focus groups with key staff from several county departments, including housing, economic development, finance, and planning and zoning. The analysis culminated in a strategic plan with several prioritized action items geared towards redirecting existing resources and tools, pursuing/dedicating new revenue sources, and the most feasible new tools or incentives to consider implementing. WSP is providing planning and zoning services in support of Loudoun County's zoning ordinance overhaul, including zoning administration, long-range community planning, land use and development review, and planning and zoning customer service.
- **Miami-Dade Transit Capital Improvement Plan Transit Engineering Services, Miami-Dade County, Florida:** conducted a real estate market analysis to provide the station area planning team with market-driven insights into the likely timing, scale, and mix of commercial and residential land uses surrounding the four station locations under consideration. The analysis included a forecast of demand for new multifamily, office, industrial, and retail land uses along the corridor, as well as each station location's likely capture of this demand potential in light of site-specific strengths and weaknesses for new transit-oriented development construction and depth of existing and new competitive



supply in the surrounding submarkets. The analysis also included an in-depth evaluation of the near- and long-term potential impacts of the COVID-19 global pandemic on various land uses, including the extent to reductions in office and retail demand were short-term, temporary, cyclical events versus permanent, structural shifts in telecommuting and online purchases. WSP is assisting in the execution of Miami-Dade Transit Capital Improvement Program projects. The firm is also implementing future corridor work program transit projects. WSP is providing professional services required for public works and transit projects, including technical and operation planning; traffic and transit studies; planning, development, and engineering studies; design permitting; engineering inspections; right of way support; surveys; structural, geotechnical, and electrical engineering; and construction cost estimating.

- **Regional Rapid Transit Project Development and Environment Study, Tampa, Florida:** assessed commercial and residential real estate market conditions at 21 potential station areas along the 40-mile corridor to help identify those with the strongest potential for economic development. The analysis included socioeconomic demand conditions and competitive supply conditions for office, residential, and retail land uses. Each station area was also analyzed at the parcel level to inventory the amount of vacant and underutilized land with transit-oriented development and redevelopment potential. WSP is conducting a study to evaluate the rapid transit connection from downtown St. Petersburg to Wesley Chapel in 41 miles of the Interstate 275 corridor. The major project elements include meeting the procedural requirements and guidance to satisfy the National Environmental Policy Act and meet all federal and state rules and regulations to seek the project's entrance into the Federal Transit Administration Capital Investment Grant program. The scope involves refining the conceptual design, considering concurrent studies and the Tampa Bay interstate modernization projects, and identifying opportunities for transit-oriented development. The formation of a project management team facilitates stakeholder involvement. The project management team includes representatives from the WSP team; project stakeholders including Tampa Bay Area Regional Transit Authority, Florida Department of Transportation, Hillsborough Area Regional Transit Authority, Pasco County Public Transportation, and Pinellas Suncoast Transit Authority; the Metropolitan Planning Organizations of Hillsborough, Pasco, and Pinellas Counties; and other parties identified by the Authority. The project team also completed public outreach activities, including in-person and virtual outreach and coordination through various media such as in-person and web-based virtual charrettes, project videos, and project workshops.
- **City of Seattle Interstate 5 Lid Feasibility Study, Seattle, Washington:** led the economic and financial feasibility elements of the overall analysis of the potential to deck over specific sections of Interstate 5 running below grade through downtown Seattle. Lid scenarios analyzed varied by vertical development intensity atop the lid structure, from 100% open space to maximum development intensity, and a hybrid scenario combining private development with several key public benefits, including large-scale affordable housing. Beyond project-level net revenue, the analysis shed light on wider benefits, such as regional economic and fiscal impacts from construction and ongoing economic activity. WSP conducted a feasibility study to construct a lid over Interstate 5 from Madison Street to Denny Way. This study investigated structural, urban design, and financial solutions necessary to bridge the existing highway and reconnect neighborhoods. The project evaluated the relative cost, schedule, permitting requirements, and constructability differences between (1) building a lid over the existing freeway, including assessment of existing freeway structures, roadways, retaining walls, bridges, ramps, utilities, etc., and (2) building the lid as part of an overall rehabilitation of Interstate 5 and what opportunities exist in redesigning the freeway to achieve optimal lid configurations. The scope of work



TIMOTHY THORNTON

Principal Consultant

included assessment, scenario analysis, finance and management, visualization, and community engagement.

- **Metro Houston General Planning Consultant Services, Houston, Texas:** assisted with Houston METRO's evaluation of two competing joint development proposals at the Texas Medical Center Transit Center. As part of a multidisciplinary team, Tim analyzed and compared the proposals from the financial perspective, to help METRO understand the likely revenue potential from an air rights lease agreement with revenue from large-scale, mixed-use development plans, including hospitality, residential, retail, structured parking, and other sources. WSP is providing general planning on-call services for the Metropolitan Transit Authority of Harris County for the development of a regional transit plan. The scope of work includes bus rapid transit studies, corridor development, park-and-ride expansion studies, and additional support as needed.
- **Cleveland Downtown Revitalization Initiative, Cleveland, Tennessee:** analyzed real estate market conditions as part of a larger planning effort for multifamily residential, hotel, office, and retail uses to help revitalize Cleveland's downtown area. In addition to market conditions, Tim's analysis provided strategic recommendations to assist the City with prioritizing investments and incentives that could be most catalytic in light of the City's near- and long-term goals. These included catalytic adaptive reuse opportunities, a main street retail tenancing strategy, and prioritizing land uses that best complement the City's identified themes of sports and recreation, business innovation, and outdoor-oriented activities. WSP was selected to provide transportation planning for the City of Cleveland Downtown Revitalization Initiative. The Initiative is focused on work that needs to be done in the public realm (street, sidewalks, public open spaces, etc.) that will support and enhance private reinvestment in downtown. In addition, the study evaluate three catalyst projects intended to help jumpstart other development.
- **City of Alexandria Development Fee Pro Forma Analysis, Alexandria, Virginia:** conducted developer interviews, gathered and analyzed development cost data, and built a financial model to test the financial sensitivity of the City's requirements on 11 case study developments planned, proposed, under construction, or recently built in Alexandria. The City of Alexandria's planning and zoning staff needed a better understanding of how its various impact fees and contribution requirements affect the financial feasibility of new real estate developments. WSP conducted a financial analysis of the impacts of the city of Alexandria's various fees on new real estate development.
- **California High-speed Rail Program Management, Sacramento, California:** led a team to analyze the historical and forecast economic impacts of the California High Speed Rail project, including direct, indirect, and induced jobs supported by the project. The analysis involved detailed analysis of historical project expenditures to assess the benefits created at both the state and local level. The team also assisted the Authority's project controls group to identify gaps in their data collection process to facilitate ongoing updates to the economic analysis. Tim also worked with the Authority's outreach group to generate deliverables geared to a variety of audiences and assisted with the delivery of an online interface that shows the economic benefits geospatially. WSP led the Rail Delivery Partner consortium providing program management for this statewide system that will total 800 miles, including 24 stations, and extend from Sacramento to San Diego. The project scope includes program and project controls, engineering and environmental services, right-of-way management, ridership and revenue modeling, operations and maintenance planning, cost estimation, and construction management support. The first 119-mile segment of the 224-mile Silicon Valley to Central Valley Line is under construction.



MIRANDA BRAATZ

Grants Development & Management Senior Consultant



Years with the firm

7

Years total

70

CAREER SUMMARY

Miranda Braatz is a senior consultant with more than 10 years of experience in team building and management, business development activities, grant writing, policy formation, and drafting budgets. She is the founder of the Economic Development Department of the City of New Carrollton and Elevated Economic Enterprises in Maryland. Miranda has also managed over \$1 million in economic development grants, helped Maryland obtain a Healthy Eating Active Living City and Towns designation, and assisted 30 cities in writing \$47.8 million in federal government grants within six months.

EDUCATION

LLM, George Mason University

PREVIOUS EXPERIENCE

Before joining WSP, Miranda's experience included:

- **Founder, Elevated Economic Enterprises, Maryland:** oversaw economic development work, grant writing, comprehensive planning, municipal and local government consulting, employer engagement, and workforce services consulting for clients, including Prince George's County, Maryland, and the National League of Cities. Miranda also assisted 30 cities in writing \$47.8 million in federal government grants within six months.
- **Chief Operating Officer, New American Strategies Inc., Houston, Texas:** oversaw the daily operations of an economic development firm with a \$100 million federal economic development contract. Miranda also managed the staff, financial matters, and business development matters. She was also an economic development subject matter expert for the firm.
- **City Manager, City of Mount Rainier, Maryland:** formed a high-functioning, technology-friendly, mobile, and responsive team to accomplish tasks and implement new ideas. Miranda also utilized economic development as a proactive tool to accomplish community goals and help diversify the financial streams and the overall financial portfolio. Additionally, she restructured and reorganized the organizational structure of the government; created two new departments, dissolved one department, reclassified seven positions, and added 10 positions; transformed three departments into high-performing teams governed by set guidelines and procedures; and created numerous policies, procedures, documents, and rules. Miranda also directly supervised six directors responsible for 45 staff; made key human resources decisions and conducted recruitments for six department heads; and drafted resolutions, ordinances, letters, policies, procedures, newsletters, policy briefs, memos, and grants. Moreover, she proposed and implemented an annual budget of \$6.7 million, \$4 million of which was in reserves; restructured and rewrote the initial budget, creating a more user-friendly model; instituted the practice of using budget amendments and reconciliations; and transformed the finance department into a high functioning and trustworthy one. Miranda also formed an economic development department and set the overall direction for the development initiatives; established an economic development incentive and financing program of more than \$1 million; discovered an alternative use for a vacant 1,000-seat theatre and created a public-private partnership with a documentary film company to turn it into a public theatre and civic space; introduced the city to an extensive network of key economic development professionals and contacts and propelled the three multimillion dollar economic development projects that had been stagnant for years.



MIRANDA BRAATZ

Grants Development & Management Senior Consultant

- **Assistant City Administrator and Founder of the Economic Development Department, New Carrollton, Maryland:** managed 85 full-time employees and oversaw a \$9 million budget. Miranda also served as the direct supervisor for one full-time employee and one part-time employee; wrote resolutions and ordinances; assisted with drafting municipal charter changes; and wrote five successful grants in 2014, which were awarded a collective amount of \$254,317. She also prepared a five-year capital improvement program and budget. Additionally, Miranda managed all grant spending and processing; oversaw, reviewed, and negotiated all contracts with a budget of more than \$7,500; served as the main point of contact for all insurance matters; and helped the finance director draft the annual budget. Moreover, she attended all budget hearings and presented the yearly budget to the City Council. She also formed a veterans' committee and got grant funding and donations worth \$35,000 to redevelop the city's veterans' park. Additionally, Miranda formed a dog park committee and raised \$23,000 to build a dog park; hosted a low-cost shot clinic for pets; and planned a dog park grand opening pet expo. Additionally, she founded a green team and leveraged the group to gain the status of a sustainable community and a sustainable Maryland-certified community and get a Healthy Eating Active Living City and Towns designation. Miranda also maintained all social media accounts; built a Twitter follower base of more than 1000 people; and drafted press releases, blog posts, and website content. As the founder of the economic development department, she helped the department grow, which included two full-time employees and a budget of \$150,000. Miranda also established a \$1 million economic development incentive fund and grew it to include eight different incentives, four tax programs, and a revolving loan fund; founded a commercial revitalization district; wrote economic development grants and managed to receive \$200,000 in grant funds in 2014; and negotiated and pursued large economic development prospects and deals, including annexation, business recruitment, and public-private partnerships. Additionally, Miranda conducted business development activities, including joining professional organizations, sponsoring events, and hosting business networking events, and actively engaged in the economic development community to help gain business for the city.
- **Community and Economic Development Fellow, City of District Heights, Maryland:** engaged in community outreach and development activities to attract businesses and enterprises to the city. Miranda also helped organize a comprehensive plan for revitalizing and redeveloping a depressed business complex and attracting and retaining the business and citizens; participated in business outreach activities, including planning citizen meetings, conducting small business outreach, creating a citizen engagement plan, coordinating community events, and engaging with citizens to explain the redevelopment and revitalization program. Additionally, she managed over \$1 million in economic development grants and wrote federal, state, and private grant applications.
- **Program Manager, American Council for Technology-Industry Advisory Council, Fairfax, Virginia:** conducted business development activities to make the clients aware of available programs. Miranda also managed a team of 42 volunteer subject matter experts to produce a 100-page white paper presented to the federal government and Congress; managed six programs, with budgets ranging from \$35,000 to \$150,000, bringing together volunteer government executives for collaborative discussions; and managed the cross-functional teams and task forces. She also managed the organization's congressional working group and implemented the necessary strategies.



JUDAH GLUCKMAN, ESQ.

Vice-President and Director, Advisory Services



Office Location

Washington, DC

Years with the Firm

4

Years total

17

Areas of Expertise

Project Management

Program Development and Capacity Building

Law, Policy, and Intergovernmental Relations

Public-Private Partnerships and Alternative Delivery

Real Estate and Economic Development

Procurement

Utility and Third Party Coordination

Education

JD, American University

BA, Policy and Economics, University Chicago

CAREER SUMMARY

Mr. Judah Gluckman is an attorney with experience serving public and private sector clients across infrastructure sectors, with expertise in public-private partnerships (P3), policy and program development, procurement, and implementation phases. He joined WSP from the District of Columbia government, where he most recently served as Deputy Director and Counsel of the Office of Public-Private Partnerships, an agency he helped create as principal drafter of its enabling legislation and grew from a staff of two to eight with a pipeline that includes a smart lighting network, joint development real estate projects, and many other assets. Before standing up Office of Public-Private Partnerships, he was Deputy Director in the Office of Policy and Legislative Affairs for Mayor Muriel Bowser, where he drafted regulations and implemented policies regarding a range of transportation, procurement, and other matters. Judah also served as the Mayor’s principal staffer on the WMATA Board. Prior to joining the government, he worked on telecommunications regulatory matters and appellate litigation for Kellogg, Huber, Hansen, and Todd, Evans and Figel. He served as a Metcalf Policy Fellow and Assistant to the Chief of Staff for Chicago Mayor Richard M. Daley. When he is not serving clients on critical infrastructure projects, he teaches a graduate-level course on government contracting at the American University School of Public Affairs and former President of Young Professionals in Infrastructure (YPI).

PROFESSIONAL EXPERIENCE

- **Highway Lid Project Due Diligence (2022–Present):** Advising a private real estate developer on the potential structuring of a highway lid project in a major midwestern city, including scoping commercial, housing, and recreational uses, the environmental and zoning processes, assignment of key roles and responsibilities through various legal structures, and engagement of state and local authorities.
- **St. Louis County Administrative Building, Deputy Project Manager (2022–Present):** Revising the master plan for all County buildings to identify efficiencies and ultimately replace a 50+ year old building that does not meet modern Building Code standards and employee/citizen expectations for a functioning government. We are evaluating a range of potential delivery models, including Design-Build and P3, as well as potential joint development and value capture solutions. It is anticipated that WSP will conduct market sounding in late 2022 and support the procurement process in early 2023.
- **Tampa Hillsborough Expressway Authority (2021–Present):** Strategic planning services to consider a range of development options for excess property, including mixed-use joint development and a multi-modal transit center. Presenting to the client’s Board and senior officials to guide them through the process and ensure alignment with long-term vision and goals. Future services may include procurement, planning, and entitlements support.
- **Lake Tavistock Autonomous Mobility Network, Procurement Specialist (2021–2022):** Advising a private developer in the administration of an FTA grant and procuring of contractors using the Design-Build model for an autonomous vehicle shuttle system and other bike and pedestrian infrastructure in a 17-acre mixed use community near Orlando, FL. Includes drafting procurement documents, coordinating with state and local governments, and supporting the property acquisition and entitlements process.
- **South San Francisco City Hall (2020):** P3 screening of key technical and financial components of a combined facility with commercial and private office space, parking, education and green space as well as strategic advice for setting up a P3 program that will facilitate the procurement of this project and future ones. Reviewed a range of site options based on zoning, land use plans, and other property characteristics and recommended those with the most build potential.



JUDAH GLUCKMAN, ESQ.

Vice-President and Director, Advisory Services

- **Amtrak CONNECT NEC Implementation Plan, Procurement Strategy (2022-Present):** As part of a larger capital planning process between Washington, DC, New York, and Boston, we are developing a new screening tool for projects to identify the best delivery models, including Design-Build, Construction Manager at Risk (CMAR), alliance contracting, and public-private partnerships. We are exploring project bundling, and other methods to optimize Amtrak's procurement process in addition to engaging the industry to identify potential bidders and address supply chain, labor, environmental, and other key risks.
- **MTA C&D, Station Accessibility P3, Technical Advisor (2022-Present):** Supporting the client in the procurement of a private partner via a P3 method to design, build, finance, operate and maintain elevator accessibility improvements at 13 different stations while minimizing impacts to riders in one of the busiest transit systems in the world. Focused on the development of technical specifications, performance metrics, and payment mechanisms for the first P3 of this kind in addition to market engagement.

Previous Experience

- **Department of Transportation, Smart Street Lighting Network, Washington, D.C.:** project manager. Responsible for the LED retrofit of 75,000 light network with smart city sensors; through performance-based design-build-finance-operate-maintain contract.
- **Department of Transportation, DC Streetcar, Washington, D.C.:** policy and legal advisor. Responsible for planning, design, construction, and operation of the first segment of this 22-mile light rail network.
- **Deputy Mayor for Planning and Economic Development, DC United Soccer Stadium, Washington, D.C.:** policy and legal advisor. Responsible for developing a state-of-the art, 20,000-seat soccer stadium that has spurred the redevelopment of the Buzzard Point area.
- **Deputy Mayor for Planning and Economic Development, The Wharf, Washington, D.C.:** policy and legal advisor. Spurring the redevelopment of the Southwest Waterfront neighborhood into a 27-acre mixed-use community with a 3.2 million square foot residential and commercial space through structuring of a tax-increment financing district.
- **Deputy Mayor for Planning and Economic Development, Walter Reed Army Medical Center, Washington, D.C.:** policy and legal advisor. Responsible for the Base Realignment and Closure Program; this included the redevelopment of a historic military facility into a 66-acre mixed-use neighborhood with 3.1 million square feet of development.
- **Department of Transportation, Transportation Network Company Regulation, Washington, D.C.:** policy and legal advisor. Responsible for developing the policy and regulatory regime for privately-owned and operated transportation services like Uber to ensure fair competition, safety, and data privacy, including autonomous vehicle rules.
- **City of Chicago, Skyway Toll Road, Chicago, Illinois:** policy advisor. Responsible for developing design-build-finance-operate-maintain procurement for an eight-mile bridge and toll road serving as the main southern gateway to the city.



SAM SPENCER

Vice President, Alternative Delivery



Years with the firm

7

Years total

15

CAREER SUMMARY

Sam Spencer is a legal advisor with more than 15 years of experience in the areas of real estate, contracts, local laws, and land use. He has negotiated complex real estate transactions and partnership agreements and administered United States Department of Transportation audits of Federal Highway Administration, Federal Transit Administration, and Federal Railroad Administration funds. As a former general counsel of the Seattle Department of Transportation, Sam has also advised agencies on the best methods of project delivery. His software skills include using Oracle to develop and implement the use of a contract management system and input more than 1,200 existing contracts and all new contracts into the system.

EDUCATION

JD, Gonzaga University

PREVIOUS EXPERIENCE

Before joining WSP, Sam's experience included:

- **General Counsel and Legal Affairs Advisor, Seattle Department of Transportation, Seattle, Washington:** served the executive team as chief legal counsel, delivering strategic legal and policy guidance supporting more than 800 employees across nine divisions and more than 70 workgroups within the matrixed organization. Sam also oversaw all litigation and contract negotiation, as well as regulatory and grant compliance for the organization with an annual budget of more than \$550 million and assets worth \$11 billion; and built the legal department structure, establishing all processes and procedures concerning claims, litigation, settlements, contracts, and risk management and establishing the risk management steering committee. Additionally, he directly drafted, negotiated, amended, and managed \$1.5 billion in commercial transactions, ensuring the city's best interests for more than 120 transactions, including software as a service, government procurement, grants, joint development agreements, data privacy, data sharing, vendor agreements, settlement agreements, service agreements, construction, and architectural and engineering contracts. Moreover, Sam facilitated the training and development of three mid-level managers, three paralegals, five real property agents, and two engineers, ensuring their understanding of all policies and procedures and federal and state regulations; served as the client representative for state and federal audits of grants, architectural and engineering contracts, procurement, and construction contract compliance of \$2 billion through 40 years; and created, negotiated, and administered requests for proposals, requests for information, requests for quotes, and other solicitations and advertisements supporting the interests of the local government. Sam also provided presentations, training, checklists, and standard operating procedures for more than 800 employees, delivering legal guidance in the areas of contract and solicitation reviews, real estate due diligence, public disclosure, grant compliance, document management, and risk management; and managed the acquisition and sale of more than \$500 million in property rights, encompassing fee simple, leases, permits, licenses, easements, and covenants. Moreover, he participated in more than 1,000 local land decisions, functioning as executive management and as a frontline employee; oversaw the litigation portfolio with more than 1,000 annual claims, analyzing needs, hiring appropriate counsel, and providing guidance throughout the litigation process and settlement decisions; and presented to elected officials, community groups, regulators, and other stakeholders concerning large-scale development and infrastructure projects. Additionally, Sam overcame a seven-year stall and directed the sale of the most significant piece of vacant land in a major U.S. city, securing \$138 million for the South Lake Union property, providing a community center, park, and more than 70 60% area median income housing



SAM SPENCER

Vice President, Alternative Delivery

units; and collaborated with various executive management, elected officials, and subject matter experts on various complex contract and real estate issues, ensuring a complete understanding of all legal areas. He also abided by statutes, codes, case laws, and policies, developing and implementing new practices and standards to simplify and align processes with organizational goals and objectives; and led the most significant transportation projects in the city's history, serving as the real estate program manager for Sound Transit 2 and 3, Mercer Corridor, The Central Waterfront Program, The Waterfront Seattle Project, The Elliot Bay Seawall Project, The Alaskan Way Viaduct Replacement Program, and The Replacement of Coleman Dock.

Additionally, Sam developed and implemented the use of a contract management system through Oracle, inputting more than 1,200 existing contracts and all new contracts into the system and establishing the ability to quickly access, reevaluate, rework, or cancel any contracts; selected, developed, and managed \$5 million to \$10 million in annual service contracts, including overseeing the performance of external counsel, commercial brokers, appraisers, title officers, relocation specialists, acquisition agents, and environmental consultants; and constructed, developed, and managed the public disclosure process for the organization, processing and closing an average of more than 150 requests each quarter and more than 700 requests per year. He also utilized the lean process review to revamp the claims response time, decreasing responses from 21 days to half a day.

PUBLICATIONS & PRESENTATIONS

Presentations

- "Title Insurance," Real Estate Transaction University of Idaho School of Law, Moscow
- "Eminent Domain," The Seminar Group Continuing Legal Education, Seattle



ANDREW PIANA

Project Controls, Lead Consultant



CAREER SUMMARY

Technically adept, multi-lingual Project manager with 15 years of experience managing multiple project portfolios in Infrastructure Development within the Private and Public Sectors.

EDUCATION

BACHELOR OF ENGINEERING, BEng, Civil Engineering (Hons) University of Nottingham, UK	2007
INTERNATIONAL BACCALAUREATE Vienna International School, Vienna, Austria	2004

Years with the firm

Less than 1 year

Years total

15 years

Professional qualifications

*Contract & Commercial Manager,
International Association for
Contract and Commercial
Management (IACCM), 2014*

ADDITIONAL TRAINING

Advanced Project Management, Miami Micro Data	2009
Project Management Administration, Miami Micro Data	2009
Primavera P6 Client Server, Miami Micro Data	2009
Engineering Economics, University of West Virginia	2013
CCM Certification, International Association for Contract and Commercial Management (IACCM)	2014

Areas of practice

Project / Delay Scheduling

Cost Engineering

Contract Management

Project Management

PROFESSIONAL MEMBERSHIPS

Association for the Advancement of Cost Engineering (AACE)	2013
Project Management Institute	2017
Association for Builders and Contractors (ABC) or Florida	2022

Languages

German

Spanish

English

PROFESSIONAL EXPERIENCE

PROJECT CONTROLS MANAGER | NV2A GROUP 2018 - 2022

Port Miami Terminal B, Miami, FL | Budget: \$239 million | Duration: 2 years

- Responsible scopes for Structural Steel, Architectural Finishes in coordination with Mechanical, Plumbing and Electrical contractors
- Develop Tenders, Procure, Budget, Track, Manage and Close-out the external contractors under my portfolio
- Develop a Cost and Schedule tracking system for Stakeholder management
- Manage external Project Managers, Engineering consultants, Architects and Engineers to develop a cost-effective and energy efficient (LEED GOLD) building
- Establish Regulatory Compliance Protocols for local Authorities Having Jurisdiction (AHJ)

PLANNING & COMMERCIAL MANAGER | ASTALDI SpA 2017 - 2018

- Manage overall contract management activities for all national projects (change orders, subcontracts, purchase orders, service agreements, schedule analysis, cost analysis, close-out)



ANDREW PIANA

Project Controls

- Develop Teaming Agreements for Legal Services, Joint Ventures,
- Actively research, support, and execute legal strategies for all matters related to international trade laws and compliance for financial closing and financial reporting.
- Support major Infrastructure Development activities during all phases of bidding, LOI, RFQs and RFPs.

CONTRACT & COMMERCIAL MANAGER | KNORR-BREMSE AG 2013 - 2017

- Taking the lead in developing project-related commercial and claim strategies within the Corporate Legal and Patent Department.
- Project controls management solutions (schedule, cost, scope) for strategic projects
- Manage operational post-merger integration for recently acquired businesses
- Support dispute resolution activities through case analysis, preparation and settlement
- Proactive Claim Management for Projects worldwide

PROJECT DEVELOPMENT MANAGER | OHL USA 2011 - 2013

- Manage Project Portfolios for Healthcare, Transportation and Facility Management Projects within \$350m - \$2B
- Evaluate, assess, negotiate Development contracts with general contractors & subcontractors for P3 Projects
- Prepare financial models for Projects during procurement, construction, and O&M
- Promote Innovative material design and equipment procurement for competitive Bid Processes
- Provide input for alternative design concepts to optimize life-cycle costs and Total Cost Management

SCHEDULER / CONTRACT MANAGER | ODEBRECHT-OHL J.V. 2008 - 2011

Airport Link Metrorail Project | Budget: \$360 million | 3 years

- Help the Project finish on time and on budget
- Plan, coordinate, and create the project baseline schedules, budgets and cash flows;
- Identify risks and vulnerabilities and develop risk models for proactive action
- Manage and coordinate over forty (40) subcontractors schedules and payment applications.

PROJECT ENGINEER | OHL S.A. 2007 - 2008

Projects type ranged from PPP's to Turnkey. This included high-tech hospitals, office buildings, courthouses and passenger stations in countries all over the world. Responsibilities included; (i) managing proposals and create budgets for the Projects within the Portfolio, (ii) Track costs and compile reports to determine whether the Projects were performing in accordance with strategic goals, (iii) Planning and Scheduling the projects within the Portfolio and Programs.



RONALD ROBERTS

Sr. Program Manager, National Facilities Programs



CAREER SUMMARY

Ron Roberts has over 30 years of valuable experience providing program management, construction management, and quality assurance in the sports facilities, K-12 education, high-rise hotel, major industrial, and institutional construction market segments. Ron has additional training in multiple project administration, construction safety, project management, and LEED construction administration. Ron has been responsible for all aspects of the construction process from program development through project closeout. Ron has managed various project delivery methods including Construction Manager at Risk (CMAR), Design-Build (DB), Design-Bid-Build (DBB), Construction, and Competitive Sealed Proposals (CSP).

EDUCATION

BS, Construction Management, Tuskegee University, Tuskegee, 1983

Years with the firm

1

Years total

30

Professional registrations

OSHA 10-Hour

OSHA 30-Hour

Affiliations

Construction Management Association of America (CMAA)

Project Management Institute (PMI)

Lean Construction Institute (LCI)

US Green Building Council (USBGC)

PREVIOUS EXPERIENCE

— Resident Engineer, Lambert – St. Louis International Airport Expansion. Responsible for the overall project supervision for construction of the North Lindbergh Temporary Bypass, Detention Facilities, Airport Maintenance Buildings and Landscaping and Central Stores Buildings. This portion is an integral part of the \$2.6 billion airport expansion. Was accountable for overall management of quality assurance, project controls, claims/warranties, project closeout and change management as well as construction administration and construction management. May 2003 through May 2004

— Construction Manager, Cross County Metrolink Extension. Assisted in the formal peer review, estimates, and constructability review for the \$350 million expansion of the St. Louis Metrolink Rapid Transit System. This review was conducted with the help of other mass transit professionals from several states. Also headed a team that reviewed the overall project for completeness, correctness and cost effectiveness. This process included a bottoms-up estimate and a review of the design for best practices consideration of the construction process. June 2002 through May 2003

— Director of Safety, Lambert-St Louis International Airport Expansion Program. Responsible for developing safety standards and guidelines for the \$2.6 billion Lambert-St. Louis International Airport Expansion Program. Oversaw the development of safety programs for individual site contractors along with creating the safety procedures for the SPK team. Also monitored the Owner-Controlled Insurance Program (ROCIP) and guided the OSHA Voluntary Protection Program (VPP). These programs ensure safety compliance while reducing cost to the owner. January 2000 through June 2002

— Project Manager, St. Louis Rams, St. Louis Regional Convention and Sports Complex Authority, St. Louis, MO. \$400 million, CSP. Ron was responsible for project testing and inspection services, precast structural concrete for the sports bowl, bowl seating, and suite construction contracts. In addition, managed the facility video production and audio/video transmittal contracts, membrane roofing, sports floor covering and floor retraction contracts. Additional responsibilities included generating and resolving punch list items, construction manager representative on the QA/QC committee and developing and implementing a high school/ college internship program with inner-city youth. Completed 1995



RONALD ROBERTS

Sr. Program Manager, National Facilities Programs

- Superintendent/ Project Manager, St. Louis Cardinals MLB, The New Busch Stadium, St. Louis, MO. Superintendent/ Project Manager, \$365 million, Competitive Sealed Proposal (CSP). Directed work of all trades interfacing on the Mezzanine Level and Field Suites Level of the project including all MEP rooms and support services. Responsible for coordinating and directing contractors' teams building sixty-three luxury suites and twenty-eight party rooms at the New Busch Stadium. Particular care required in the installation of luxury finishes. A fixed end date required emphasis on completion schedule. Directed contractor punch list completion. Completed 2006
- Project Manager, Aria Tower/City Center, Las Vegas, Nevada. \$1.6 billion, 4,004-room resort hotel. LEED Gold. Directed team of Cost Engineers and Superintendents to develop a line item Guaranteed Maximum Price (\$1.6 billion) for the Aria Tower at City Center. Supervised subcontractor buy-out and negotiations with apparent low bidders to secure "added value". Worked in conjunction with project General Superintendent to ensure timely installation and with project design teams for architectural integrity. Completed 2008.
- Construction Manager, Metro Transit – St. Louis, Cross County Metrolink Extension, St. Louis, MO. \$350 million. Assisted in the formal peer review, estimates, and constructability review for the expansion of the St. Louis Metrolink Rapid Transit System. This review was conducted with the help of other mass transit professionals from several states. Also headed a team that reviewed the overall project for completeness, correctness and cost effectiveness. This process included a bottoms-up estimate and a review of the design for best practices consideration of the construction process. Completed 2003
- Field Inspector, St. Louis Metropolitan Sewer District, Deer Creek Bore Tunnel, St. Louis, MO. \$83 million, CSP. Using an enormous Tunnel Boring Machine (TBM) dubbed "Mrs. Nancy," contractors bored the tunnel through deep rock 150–250 feet below ground surface. The inside was finished with a concrete liner, leaving a diameter of approximately 19 feet. The construction shaft, which later served as part of the pump station that drains the tunnel, was located at the downstream end of the tunnel near I-44 and Shrewsbury Avenue. Completed 2018
- Senior Project Director, Lone Star College, Kingwood Campus Build-Back, Houston, TX. \$38 million, CMAR. Developed project scope and coordinated short- and long-term architectural/engineering plans and programs for design, construction and alteration of facilities. Worked with the colleges campuses to coordinate efforts of capital construction project teams. Monitored, administered and managed project budgets, including pay applications submitted by building contractors, testing laboratories, consulting engineers and surveying firms. Implemented budget controls, performed needs assessments for development and/or revisions of budgets as needed and maintained communications with the Executive Director of Construction and the consulting team/external construction managers through the development of projects. Worked within FEMA Guidelines for campus build-back at LSC Kingwood May 2018 through July 2021. Completed 2021
- Program Director, Houston Independent School District, 2012 Bond, Houston, TX. Program Director for \$300 million of the \$1.8 billion program, CMAR. Managed one of five program management teams for the Houston Independent School District's Bond Program. Management team responsible for six new high schools and an early childhood center. Process managed from planning, design, CMAR bid process through abatement, demolition, new construction, punch-list and move-in. Responsibilities included team oversight, community engagement, consultant and contractor management. Completed 2016



JOHN LOUGHRAN
Senior Urban Strategist



CAREER SUMMARY

John Loughran brings progressive experience in urban design, planning, and architecture with an expertise in transit-oriented development. He understands the relationship between the built environment and transportation, and the complexities of integrating mixed-use development with transportation infrastructure.

John has led the preparation of a wide range of large-scale land use and transit-oriented development studies, urban design plans, and development proposals that respond to neighborhood and physical context, economic constraints, and stakeholder needs. He has worked closely with planning and government officials on successful project entitlements, prepared formal land-use applications, and development proposals in compliance with appropriate regulations and policies. In addition, he has worked with clients to develop and organize public participation through a variety of communication techniques such as open houses, focus groups, agency meetings, and stakeholder workshops.

Years with the firm

6

Years total

26

EDUCATION

BS, Architecture, Catholic University, 1984

MS, Business Administration, Baruch College - Cuny, 2011

PROFESSIONAL EXPERIENCE

- **Downtown Cary Multimodal Feasibility Study, Cary, North Carolina:** lead urban designer who is evaluating sites for conformance with station area design criteria. A concept plan is being developed that illustrates transit capacity and alignments, mixed use development opportunities, staff, parking options, and an analysis of site access and pedestrian and bicycle connections. A vision statement will guide placemaking and open space design to guide the future planning of the Transit Center and the station area. WSP was selected to conduct a multimodal feasibility study in downtown Cary, North Carolina, for site selection and planning to expand Cary's Amtrak station to be fully multimodal. The project scope involves community research; functional needs assessments; design workshops; security assessments; transit-oriented development opportunities; coordinating across multiple municipalities; transit agencies providing bus, bus rapid transit, para-transit, and commuter rail; state and federal railway services; emerging modes of transit; integration with a walkable downtown core; downtown parking needs; and community integration.
- **North and West Corridors Alternatives Analysis Study, Charlotte, North Carolina:** urban designer who participated in workshops for multiple transit corridors and is working with local planning officials to understand how alternative alignments and modes of transit could impact communities and neighborhoods. He is considering impacts on the built environment and open space and identifying strategies to leverage transit investments to meet municipal goals, such as the potential for transit oriented development. WSP is performing an alternative analysis study of the LYNX North and West corridors for the Charlotte Area Transit System. To ensure overall system connectivity, this study evaluates rail alignment and service integration through Center City Charlotte to determine how best to connect the future corridors.
- **Rhode Island On-Call Engineering Services, Rhode Island:** WSP is currently providing on-call engineering services for The Rhode Island Turnpike and Bridge Authority. Services



include electrical upgrades, cable investigations, construction support, and deck evaluations for roadway and bridge repairs.

- **Sakonnet River Bridge Landings Feasibility Study for Land Use Master Plan, Rhode Island:** land use planner who developed and created preliminary scenarios based on "destination waterfront" and "commercial waterfront" focused mix of uses. He tested the feasibility of each based on existing conditions; a preliminary market assessment; interviews with town officials; and an evaluation of land use suitability, development impacts, and revenue generation potential. WSP was retained by the Rhode Island Turnpike and Bridge Authority (RITBA) to prepare a preliminary study to assess the feasibility for land development of RITBA-owned parcels of land near the Sakonnet River Bridge and recommended whether to pursue a full master plan.
- **City of Los Angeles 2017 On-call Taylor Yard River Park Project, Los Angeles, California:** provided urban design and community planning services. He also served as lead urban designer who created a vision of a newly accessible Los Angeles River as a meandering watercourse in a naturalized and greened basin connected to nearby state and city parks with complete streets, pocket parks, and bicycle paths. WSP is providing on-call engineering services for the development of new concepts to convert a contaminated former railroad yard into a community park. The project includes environmental and geotechnical site assessments, community stakeholder engagement, and development of an implementation plan/pre-design report which will include both early and long-term uses of the site. The 40-acre riverfront parcel is considered the "crown jewel" in the City's visionary plan to revitalize 31 miles of the Los Angeles River.
- **Interstate 84 Hartford Program, Hartford, Connecticut:** WSP USA led an urban design effort that identified transit-oriented development opportunities that will benefit communities surrounding the Interstate 84 highway corridor. As the prime consultant, WSP worked on a peer review of the project and created a concept plan that will improve mobility and access, create a district that strengthens a sense of place for the community, and sets the stage for economic development connected to transit.
 - **Capital Gateway TOD Concept Plan, Hartford, Connecticut:** project manager. WSP was commissioned to help the City achieve its goals in the I-84 project area and represented the City's interest in the state department of transportation-led engineering design process. The plan developed urban design strategies and preferred infrastructure design elements for the relocated highway, realigned Hartford-Springfield rail line, and CTfastrak bus rapid transit essential to implementing the City's vision for transit oriented development. The plan is transformative, stitching together downtown and neighborhoods that had been divided by the original I-84. It creates a new center for the City around a new Intermodal Transit Center. The plan recommends decks at strategic locations to enhance the pedestrian environment and identified implementation strategies including financial solutions to support the City in implementation.
- **Task Order Transit-Oriented Development Support Services, Connecticut:** WSP provided the Connecticut Department of Transportation with transit-oriented development support services as part of this task-based agreement that focuses on transit-oriented development planning on key rail and bus rapid transit corridors throughout Connecticut and developing a systematic framework for transit-oriented development that promotes transit-friendly development and achieves regional economic growth.



- **Hartford Line TOD Action Plan, Connecticut:** lead urban designer and contract manager. The Connecticut Department of Transportation (CTDOT) initiated the Hartford Line TOD Action Plan to complement more frequent and faster passenger rail service along the corridor as part of the NHHS Rail Program. The WSP team is assisting CTDOT to create more livable and sustainable communities by identifying economic development, land use, and public realm improvement strategies to activate TOD in selected station areas. As part of this effort, the WSP team is assessing TOD potential that is grounded in an understanding of market conditions and supported by interviews with anchor institutions and developers, as well as engagement with key stakeholder groups and the public, to inform the identification of catalytic sites for TOD.

- **Metropolitan Atlanta Rapid Transit Long-Range and Short-Range Planning, Atlanta, Georgia:** WSP provided on-call planning and technical services for the Metropolitan Atlanta Rapid Transit Authority. Task-order efforts included a comprehensive operations analysis, the Interstate 20 East Transit Initiative, the Georgia 400 Transit Initiative, public outreach, service planning and scheduling, the Interstate 20 East Transit-Oriented Development Implementation Study, Arts Center Transit-Oriented Development Environmental Assessment, and environmental document support for Edgewood and Candler Park, Avondale, and King Memorial Station transit-oriented development efforts.

- **I-20 Transit Oriented Development Strategic Plan, Atlanta, Georgia:** lead urban designer who is providing a corridor-wide analysis of opportunities for transit oriented development and identifying catalytic projects that will spur private investments in transit oriented development. The goal is to leverage investments in transit with a realistic and implementable plan that spurs economic development. The process focuses on equitable outcomes to create transit oriented development strategies unique to each of the six station areas that will create opportunities for economic growth in a slow-growing part of DeKalb County. WSP assisted MARTA and DeKalb County in the development of a grant application for the Federal Transit Administration (FTA) Transit Oriented Development (TOD) Pilot Grant Program. MARTA and DeKalb County were successful in securing \$1.6 million, the largest single award in the country, to develop an implementation strategy for TOD along the I-20 East high capacity transit expansion corridor. Combined with a local commitment of \$400,000, this led to the \$2 million MARTA I-20 East TOD Implementation Study led by WSP. This effort engages stakeholders including elected officials, developers, and citizens in the development of an implementable strategy to support economic development and land use changes in station areas. The outcome will be a transit-supportive community strategy that is market-based and reflects the desired future development in the area. Implementation of the recommendations will enhance characteristics that improve the I-20 East corridor's competitiveness for limited federal transit funds.



AMY DICARLANTONIO, AICP, ENV SP, LEED APBDC

Urban and Environmental Planning



Years with the firm

14

Years total

23

Professional registrations

American Institute of Certified Planners: US (023833)

Envision Sustainability Professional: US (346)

Leed Ap Building Design + Construction: US (10076723)

CAREER SUMMARY

With more than 20 years of national and international experience, Ms. DiCarlantonio has held a variety of roles including national practice lead for planning, regional manager, and program and project manager. Ms. DiCarlantonio has a diverse portfolio of project experience spanning environmental planning, master planning and urban design, community resiliency, and federal planning for the Department of Defense.

Ms. DiCarlantonio is skilled at integrating various technical disciplines for environmental planning projects and specializes in directing the built and human environment sections (population and housing, transportation, and land use evaluations) for EISs, EAs, EIRs, and other documents prepared in compliance with NEPA and CEQA for renewable energy projects, transmission facilities, pipelines, military facilities, and urban and residential development projects. Her urban development expertise includes identifying challenges and formulating recommendations to mitigate conflict areas for various development initiatives, including infrastructure projects and solar and other renewable energy facilities. Throughout her planning career, Ms. DiCarlantonio has led and supported various public participation and community outreach programs including developing programs for city and state clients.

PROFESSIONAL EXPERIENCE

- **California Public Utilities Commission Alberhill System Project California Environmental Quality Act Services, San Francisco, California:** WSP provided an environmental impact report pursuant to the California Environmental Quality Act for the Alberhill substation and associated transmission lines proposed by Southern California Edison. The project includes a new 34-acre, unattended substation and approximately 25 miles of new and replacement transmission lines. The combined Valley-Ivyglen and Alberhill Project final environmental impact report was published in April 2017. The California Public Utilities Commission issued its decision for the two projects on August 31, 2018. The decision directed Southern California Edison to supplement the existing record for the Alberhill Project with additional analyses of alternatives that may satisfy the needs of the Valley South system. Additional analyses include, but are not limited to, energy storage and non-wires alternatives, and a demonstration of need. The WSP team is assisting the California Public Utilities Commission with an assessment of the supplemental analyses.
- **Alberhill Substation and Transmission Lines, Riverside County, San Francisco, California:** project manager for the post decision analysis phase of the project. Amy is writing the transportation section of WSP's third-party environmental impact report for this proposed new substation and new and replacement transmission and subtransmission lines of Southern California Edison. WSP is providing the California Public Utilities Commission a comprehensive analysis of the traffic volumes and level of service of the interstate highways, state highways, and local roads within the project area. Additional analyses include, but are not limited to, energy storage and non-wires alternatives, and a demonstration of need.
- **Naval Facilities Engineering Command Atlantic Division Planning Services, Nationwide:** WSP is providing environmental planning services for tasks assigned by the Naval Facilities Engineering Command Atlantic Division.
- **Joint Base Pearl Harbor-Hickam Encroachment Action Plan Update, Nationwide, Nationwide:** project manager for an update of the 2010 Encroachment Action Plan managing the facilitation strategy for several on-site workshops and interviews for the large-scale base with numerous stakeholders, an innovative mission analysis, overall schedule, and budget. WSP is updating the 2010 Encroachment Action Plan to sustain

the Navy and Air Force's ability to perform its mission. Encroachment action plans are internal Navy documents that identify encroachment and land use compatibility issues and provide strategies to prevent or mitigate impacts on installation facilities and missions. Encouraging military and community compatibility benefits both the mission sustainment objectives of an installation and the quality of life and environment for the surrounding citizens. The end goal of encroachment management is to ensure that the military can continue to conduct its training and operational missions in a way that is complementary with the surrounding communities.

- **NYSDOT Buffalo Skyway Environmental Impact Assessment, Buffalo, New York:** technical advisor for land use development and analysis associated with the removal of the Buffalo Skyway infrastructure. WSP is providing environmental planning services to the New York State Department of Transportation for an environmental impact assessment in support of the Buffalo Skyway removal. Removal of the Buffalo Skyway elevated structure and realignment of the existing transportation network will support existing and planned recreational, mixed-use, and waterfront development in the Buffalo Outer Harbor and Inner Harbor areas. As a major infrastructure project, the environmental impact statement complies with Executive Order 13807, that is, Establishing Discipline and Accountability in the Environmental Review and Permitting Process, and its accompanying Memorandum of Understanding Implementing One Federal Decision under Executive Order 13807.

OTHER WSP EXPERIENCE

- **Air Installations Compatible Use Zones Studies at Air Reserve Bases, Multiple Locations:** project director developed Air Installation Compatible Use Zone studies for Grissom Air Reserve Base, Indiana; Homestead Air Reserve Base, Florida; and Westover Air Reserve Base, Massachusetts. As project director, Amy provided guidance, direction, and overall quality assurance/quality control for all deliverables. WSP provided Air Installation Compatible Use Zone studies to the U.S. Air Force describing airfield operations and depicting zones of greatest accident potential and high noise, identifying other land use-related concerns, and containing recommendations for compatible development. The goal of the Air Installation Compatible Use Zone program is to protect the health and safety of communities from the effects of aircraft operations while ensuring the continued viability of the Air Force's operational mission. Air Installation Compatible Use Zone studies are conducted to assist the Air Force in reaching this goal by promoting proactive, collaborative planning for compatible development. Each of these projects have included providing support to Air Force Civil Engineer Center through all phases of an Air Installation Compatible Use Zone project, including conducting on-site interviews and data collection; completing land use compatibility analysis; conducting accident potential zones and noise assessments; preparing the Air Installation Compatible Use Zone Study Document and associated public outreach materials, including a real estate map brochures, citizen's brochures, and banner stations; and coordinating and attending public open houses.
- **Coconino County Joint Land Use Study, Arizona:** technical advisor for the light pollution assessment and related environmental issues. Amy provided meeting presentations and facilitated interviews and workshops during the development of the local compatibility issues and mitigation strategies. She also drafted Joint Land Use Study sections related to dark sky preservation, forest health, air and water quality, wildfire and disaster hazards, and wildlife movement corridors. WSP provided Coconino County, United States Naval Observatory Flagstaff Station, and Arizona Army National Guard Camp Navajo a joint land use study which aimed to ensure lasting compatibility of military installations and neighboring communities. Associated strategies focused on coordination between local entities and agencies, developing and executing an education program to raise dark sky awareness, updating lighting codes and enforcement techniques, exploring land

conservation strategies, and enhancing forest management and restoration practices. The Coconino Joint Land Use Study was an 18-month effort primarily funded by the Department of Defense Office of Economic Adjustment, with contribution from participating municipalities.

- **14th Street, NW Multimodal Transportation/Streetscape Design Study, Washington, D.C.:** task manager for this planning and public involvement project. Amy led the development of a sustainable infrastructure and public art plan that could be incorporated into functional streetscape elements. She integrated public art into a sustainable streetscape design to help define public open spaces along the corridor, reinforce its unique historic character, and create a sense of place for the 14th Street/Logan Circle/Shaw neighborhood. She organized and led public consultation meetings, land use/public realm analyses, the development of streetscape design alternatives for the corridor, and the integration of low impact development techniques into the streetscape design. WSP provided the District Department of Transportation a design study for a public involvement project intended to develop and recommend balanced strategies for a multimodal transportation and streetscape plan. The planning goals for this popular District of Columbia redevelopment area were to preserve and strengthen a vibrant, mixed-use corridor, improve safety and mobility throughout the neighborhood and regional transportation system; and provide cohesive support for current and future area development plans.
- **Aliso Canyon Natural Gas Turbine Replacement Project, Aliso Canyon, California:** led the preparation of the land use section of WSP's California Environmental Quality Act environmental impact report for this natural gas turbine replacement project of Southern California Gas Company. Amy's knowledge of southern California's jurisdictions allowed her to successfully organize a succinct, well-written, and legally defensible California Environmental Quality Act land use section. WSP provided the California Public Utilities Commission with an environmental impact report for a natural gas turbine replacement project. The project includes a retrofit of the existing facility and replacement of out-of-date, turbine-driven gas compressors with new, variable-frequency compressors. Due to the reconditioning project component, the environmental impact report land use section included an analysis of existing conditions and impacts within several jurisdictions at the county and city levels.
- **Anacostia Waterfront Transportation Architecture Design Guidelines, Washington, D.C.:** planner contributed to the development of design guidelines and standards to provide unified transportation architecture for all roadway and transportation-related construction projects in the 900-acre Anacostia River redevelopment area. Amy edited the design standards manual, including both written and graphic materials; and she researched and wrote portions of various chapters including the low impact development chapter. WSP provided a reference manual and interactive compact disk that could be used to help select appropriate planning elements for any street within the Anacostia study area to the District Department of Transportation. The manual also incorporated environmental planning components and low impact development/stormwater management solutions. Nonstructural and structural concepts such as the application of manmade materials like permeable pavers and filter boxes were included, along with reconfiguration elements involving use of natural spaces like vegetated swales, vegetated filter strips, and bioretention facilities. The manual provided visual and technical information to enable city planners to make educated decisions on low impact development practices that could successfully be implemented along transportation corridors. The primary low impact development strategies were referenced throughout the manual for appropriate streetscape elements. Low impact development concept details were presented in a separate chapter that included an overview of each strategy, application, required maintenance, and stormwater management effectiveness.



HEATHER MARTIN, AICP

Senior Lead Equity Consultant



CAREER SUMMARY

Heather Martin has 12 years of experience focused on bicycle and pedestrian studies and research methodologies, traffic safety and crash analysis, complete streets, transit facilities planning and funding, multi-modal transportation and policy analysis, urban revitalization, and public involvement. Heather has served a variety of public-sector clients at WSP and previously work for government research, planning, and transportation agencies. Heather is a highly skilled writer, presenter, and meeting facilitator and is proficient in Adobe Creative Suite, ESRI GIS analysis, and Google Earth.

EDUCATION

MA, Urban And Regional Planning, Rutgers University-The State University of New Jersey, 2013

Years with the firm

7

Years total

10

Professional registrations

American Institute of Certified Planners: US (028593)US (028593)

PROFESSIONAL MEMBERSHIPS

American Institute of Certified Planners

PROFESSIONAL EXPERIENCE

- **General Engineering and Construction Management Services for SEPTA, Philadelphia, Pennsylvania:** WSP is providing general engineering and construction management services to the Southeastern Pennsylvania Transportation Authority. Individual projects include the 15th Street Station Renovation Project, Swarthmore Station roof replacement, Americans with Disabilities Act trolley station evaluation, 69th Street Substation relocation, program management and oversight for a trolley modernization project, and Phase 1 construction rehabilitation services for the Ardmore Transit Center.
 - **Southeastern Pennsylvania Transportation Authority Trolley Modernization Program, Philadelphia, Pennsylvania:** project planner for program management of SEPTA’s trolley modernization program. She provided management support, prepared task orders and meeting materials, analyzed ridership, and evaluated key vehicle specifications. WSP is leading a program management and oversight effort to modernize Southeastern Pennsylvania Transportation Authority's six trolley routes by upgrading the infrastructure and supporting systems to accommodate a fleet of fully accessible articulated vehicles.
- **City of Baltimore On-Call Transportation Planning, Baltimore, Maryland:** project planner for an environmental assessment of the impacts of major planned development on I-95 ramps, bridges, and local streets. She worked with together with stakeholders from the Federal Highway Administration, Maryland Transportation Authority, Baltimore City, developers, and other consulting firms on the assessment, providing advisory and coordination services for the Baltimore City Department of Transportation throughout the NEPA process. WSP provided on-call services in transportation planning, transportation-oriented development, freight studies, feasibility studies for all modes, environmental justice, public involvement and community engagement, funding strategies, urban design, environmental analysis and documentation and water transportation planning for the Baltimore City Department of Transportation.



HEATHER MARTIN, AICP

Senior Lead Equity Consultant

- **Baltimore and Potomac Tunnel Replacement, Baltimore, Maryland:** project planner on the NEPA study of the potential realignment of the Baltimore and Potomac Tunnel underneath Baltimore City. Working together with stakeholders from the Federal Railroad Administration, Amtrak, Baltimore City, and other consulting firms, a preferred alternative rail tunnel route was selected and a final environmental impact statement was created, as required by NEPA. Project work included coordinating the engineering team's involvement in the NEPA process, preparing ARRA quarterly reports, and providing document control support and contract management. WSP leads the joint venture designing a new Baltimore and Potomac Tunnel, which will upgrade a 4-mile section of the Northeast Corridor and eliminate the existing tunnel's sharp curves, allowing Amtrak and Maryland Area Regional Commuter trains to travel at higher speeds. It includes two new high-capacity tunnels for electrified passenger trains, new roadway and railroad bridges, new rail systems and tracks, and a new Americans with Disabilities Act-accessible West Baltimore Maryland Area Regional Commuter station. The project also includes the construction of three new ancillary facilities to ensure proper ventilation of the tunnels.

OTHER WSP EXPERIENCE

- **BaltimoreLink Launch, Baltimore, Maryland:** embedded WSP staff for the Maryland Transit Administration who served as a BaltimoreLink Transit Ambassador providing front-line customer assistance, explaining route and service changes, and assisting with the public hearing process.
- **MTA Federal Grant Management, Baltimore, Maryland:** embedded WSP staff for MTA who was the Capital Program Senior Advisor managing grant administrators, ensuring successful development of more than 20 federal grant applications and internal budgets, and preparation of financial reports for the executive leadership team. Heather was also responsible for overseeing all grant-related changes to all metropolitan Transportation Improvement Programs (TIPs) in the state of Maryland and the Statewide Transportation Improvement Program (STIP). Through this experience, Heather has become extremely familiar with the Federal Transit Administration's (FTA) Transit Award Management System (TrAMS), quarterly milestone progress reports, budget revisions, grant amendments, grant status logs, and working with FTA Region III staff.

PREVIOUS EXPERIENCE

Before joining WSP, Heather's experience included:

- **Baltimore City Department of Planning, Baltimore, Maryland:** central district planner at Baltimore City who led planning initiatives around schools and commercial corridors to create safe and appealing environments, boost economic activity, and improve residents' quality of life. She conducted a walkability audit with stakeholders around two elementary schools. She led numerous public meetings and advised city officials, agency staff, and community stakeholders on planning, policy, and development matters. She developed and grew relationships with community leaders, organizations, and businesses in sixteen neighborhoods. She also created GIS maps, conducted census research, wrote reports, and prepared presentations.
- **Long Island LGBT Community Center, Bay Shore, New York:** development coordinator who analyzed donor trends to increase donations by \$12,000, organized marketing for Partners in Pride creating \$20,000 in new revenue, and coordinated fundraising events sponsored by 175 businesses for over 350 guests.



HEATHER MARTIN, AICP

Senior Lead Equity Consultant

- **Manhattan 3rd Avenue Traffic Safety Study, New York, New York:** graduate fellow who researched and wrote the “Manhattan 3rd Avenue Traffic Safety Study” report focused on identifying high-risk user behaviors and recommending policy and design improvements to increase safety for vulnerable road users. She created the research strategy and methodologies, collected pedestrian, cyclist, and vehicle data, analyzed high-risk behaviors, and researched best practices. She developed policy and design recommendations including bicycle lanes protected by a floating parking lane, pedestrian islands, and red light cameras.
- **MTA Bus Safety Planning, Baltimore, Maryland:** project planner for a safety and security analysis of the Maryland Transit Administration's (MTA) new bus network. Heather researched and evaluated corridor context, conducted field visits to proposed bus stop locations, evaluated potential hazards, and proposed mitigation strategies for hot spot stop locations and routes. She analyzed bus traffic incident and crime data to support safety and security analyses. She also coordinated with multiple MTA departments to ensure appropriate safety department review of all major project elements involving safety and security compliance and certification.
- **New Brunswick Ciclovía 2013 Evaluation Report, New Brunswick, New Jersey:** research manager at the University who researched and wrote the "New Brunswick Ciclovía 2013 Evaluation Report." The report analyzed the success of the open streets event at improving health, economic, and social outcomes. She developed the research strategy and methodologies, created the intercept survey and structured interview questions, conducted pre- and post-event stakeholder interviews, analyzed survey data, and supervised volunteers and graduate assistants.
- **NYCDOT Research, Implementation, and Safety, New York, New York:** planning intern at NYCDOT who analyzed streets and intersections to determine suitability for safety improvements, researched crash statistics, analyzed crash patterns, and proposed design solutions to improve safety for all road users. She also created GIS maps and collected data.
- **Pedestrian and Bicycle Resource Center, New Brunswick, New Jersey:** research manager at the University who developed complete streets solutions for local New Jersey municipalities. She supervised all elements of the complete streets studies including existing condition reports, data collection, stakeholder meetings, and analysis of crash hot spots. Recommendations included context specific improvements such as curb bump outs, high visibility crosswalks, flashing beacons, streetscaping improvements, and bike lanes.
- **Stony Brook University, Stony Brook, New York:** advancement communications associate who assisted with increasing online fundraising by 200% with customized donation forms, facilitated over 150 online and print fundraising projects per year under tight deadlines, and spearheaded the Alumni Association's social media presence.

PUBLICATIONS & PRESENTATIONS

Presentations

- “Beyond the Waterfront: Successful Baltimore Neighborhood Revitalization Projects,” APA Maryland & Delaware Regional Planning Conference, Towson, MD, 2016



TODD TEUSCHER, LA, LEED 2.2

Lead Architect



CAREER SUMMARY

Todd Teuscher is a senior landscape architect with extensive experience in master planning, urban design, streetscape design, site design, specialty detailing, recreation planning, pollinator habitat design, and landscape design. His responsibilities include preparing master plans, graphics, site designs, construction documents, design analysis reports, and development guidelines for various landscape architectural projects.

EDUCATION

BA, Landscape Arch, Kansas State University, 1989

PROFESSIONAL EXPERIENCE

Years with the firm

20

Years total

34

Professional registrations

Landscape Architect: IL (157.001226); KS (607); MO (2003030828); NC (0978)

Leed 2.2 Accredited Professional: MO

Areas of practice

Aesthetic

Enhancements

Streetscape Design

Urban Design

Recreation Planning and Design

Master Planning

Site Design

Landscape Design

Transportation Design

Professional Memberships

American Society of Landscape Architects

— **US Route 183 Bergstrom Design-Build Project, Austin, Texas:** landscape architect responsible for the design of 8 miles of right-of-way planting. The design tasks include detailing of wall and structure aesthetics, layout and construction detailing of a shared use path, trail heads, trail head parks, rest areas, and connections to sidewalks and pedestrian overpass bridges. The landscape design represents the regional landscape character by using native, drought tolerant plant species in planting arrangements, transitioning from native and naturalized masses along the shared use path to more formal arrangements at intersections, rest areas, trail head parks, and connections to pedestrian facilities. WSP is the lead designer for this project reconstructing 8.5 miles of U.S. Route 183 South, also known as the Bergstrom Expressway. The improved expressway features three tolled, signal-free lanes and two to three non-tolled general-purpose lanes in each direction; five grade-separated interchanges; 40 new bridges; two direct-connect flyover ramps; upgraded major interchanges; an intelligent transportation management system; and a shared-use bicycle and pedestrian path.

— **St. Louis Board of Public Service Airport On-Call Design Services, St. Louis, Missouri:** WSP is providing on-call engineering services to the Lambert-St. Louis International Airport. Tasks include entrance road bridge rehabilitations (involving pavement evaluations and condition assessments), curbside structural repairs, a 350-space parking lot expansion, garage structural repairs, Airfield Maintenance Facility potassium acetate tanks, arterial roadway tunnel inspection, drainage improvements, and frontage road landscaping.

▪ **Lambert International Boulevard Landscaping, St. Louis, Missouri:** landscape architect responsible for preparing design and construction documents for landscape renovation along entrance roads and ramps serving the main terminal. WSP provided design services for new planting designs and other landscape improvements along the main terminal road, Lambert International Boulevard. The landscape design focused on introducing flowering shrub and perennial species to provide food and habitat for the Monarch Butterfly and other migrating butterfly species.

— **City of Lewisville Interstate 35E Aesthetic Improvements, Farmers Branch, Texas:** landscape architect responsible for preparation of construction documents for the interchange and multi-use trail at Farm to Market 407 and Interstate 35E. The construction documents incorporated portions of the themed design concepts previously prepared for this portion of the 8-mile design corridor. They included design detailing of a 15-foot by 60-foot custom wall graphics of Lake fish and wildlife scenes, a 30-foot four-sided banner poles, pedestrian scale lighting, raised planters, colored concrete wave pattern trail pavement, barrier walls, and wayfinding signage. WSP provided design services for aesthetic



TODD TEUSCHER, LA, LEED 2.2

Lead Architect

improvements made to a cross street interchange in Lewisville. WSP reviewed the aesthetic components of the design plans that pertained to conformance with the City of Lewisville Interstate 35E Corridor Identity Plan prepared by WSP in 2012.

- **Fulton State Hospital Psychiatric Facility Design, Fulton, Missouri:** landscape architect responsible for the schematic site design, which covered 42 acres. Outside the secured perimeter, the site design includes parking for 500 employees and visitors, a formal circle entrance drive surrounding a great lawn public gathering space, a building entrance plaza, and paved sidewalk and bike path connections for employees and the surrounding community. The site landscape, including secured resident outdoor spaces, utilizes predominately native Missouri trees, shrubs, grasses, and wildflower masses. WSP is providing design and construction administration services for the replacement of the Fulton State Mental Hospital, including the existing high and intermediate security facilities. The replacement will feature 12 living areas with a total of 300 beds organized into four communities based on treatment programs. Other elements include a new central energy plant and maintenance facility, and a new dietary facility with materials management and environmental services for the entire campus.

- **Oakland County Fish Lake Road Construction Management Services, Oakland County, Michigan:** landscape architect responsible for the design and detailing of stream and stream bank stabilization methods for the 600-foot length of Swartz Creek. The design includes in-stream slope and flow control structures, the addition of stream bottom material to withstand a minimum flow of 90 cubic feet-per-second, arming the stream banks with a combination of riprap toe protection, native tree and shrub live-stakes, native vegetative seeding, and an erosion control blanket over the bank slopes. WSP is providing construction management services for a large culvert replacement project in northwestern Oakland County. This project includes the removal of double corrugated metal pipe culvert failure in perched condition and replacement with a natural bottom aluminum box culvert, stream regrading, landscape architecture, erosion control measures, and stream rehabilitation.

- **Alternative Contracting General Engineering Consultant, Minneapolis, Minnesota:** WSP is providing the Minnesota Department of Transportation with design services to manage the procurement of alternative delivery contracts. This project includes pre-design activities, risk management services, and developing new approaches to alternative finance. A significant portion of the general engineer consulting work will also include supporting the development and administration of an enterprise risk management framework at the program, project, operations, and corporate levels.
 - **Trunk Highway 169 Nine-Mile Creek Bridge, Minneapolis, Minnesota:** landscape architect responsible for conceptual design preparation for an elevated walled highway through an existing wetland. The design includes proposed formliner finish aesthetic treatments suggesting architectural precast columns and arches to reference the historic and cherished arched bridge forms found throughout Minnesota. WSP is providing design services for the replacement of the Trunk Highway 169 Bridge over Nine Mile Creek. The project included areas of pavement repair, pavement resurfacing, noise wall construction, Americans with Disabilities Act improvements, lighting, intelligent transportation systems, pavement markings, signing, drainage improvements, and the replacement of Bridge No. 27568 with a Causeway between Brenn Road and the 7th Street interchange.

- **Interstate 290 (Eisenhower Expressway) Engineering and Environmental Services, Chicago, Illinois:** landscape architect responsible for the preparation of conceptual landscape plans for proposed improvements to the multi-modal urban transportation

corridor. The plans include interchange landscape design studies, creating neighborhood edge park space, and introduction of a multi-use trail. Todd is also involved in creating perspective renderings to convey design details of a key streetscape, signature pedestrian bridge, and highway buffering along the corridor for use at public presentations. WSP provided the Illinois Department of Transportation with complete preliminary engineering and environmental studies for a 13-mile section of the Eisenhower Expressway (Interstate 290) through a tightly constrained, well built-out urban corridor from Mannheim Road to Cicero Avenue.

- **Dallas Horseshoe Link Design, Dallas, Texas:** landscape architect responsible for preparing aesthetic and structural construction documents. The assignment includes detailing and preparing specifications for aesthetic treatments and painting of bridge structures, signage towers, sign structures, barriers, and retaining wall structure. WSP was the lead engineer responsible for the design of roadways, bridges, retaining walls, and drainage; geotechnical engineering; and maintenance of traffic planning for the interchange along Interstate 30 and Interstate 35 to downtown Dallas. The firm was responsible for the construction of 6 miles of new roadway. The project included the construction of more than 73 lane miles of new roadway, 37 conventional bridges, more than 60 retaining walls, and two signature steel suspended arch bridges.
- **Illinois Department of Transportation Illiana Highway Phase 1 Study, Merrillville, Illinois:** landscape architect responsible for developing sustainability and context sensitive solutions design for the 46-mile corridor connection. The context sensitive solutions plan blends the highway into the landscape with native grass and woodland restorations; creation of numerous wildlife corridor under-pass connections; and site grading to create naturalized undulating land forms, wetland restorations, planted stormwater swales, and micro-riparian habitat. WSP provided planning services to prepare National Environmental Policy Act-compliant Tier 1 and Tier 2 environmental impact statements for the Illiana Corridor, a 50-mile access-controlled highway developed in partnership with the Illinois Department of Transportation and the Indiana Department of Transportation. The highway, implemented by a public-private partnership, will connect Interstate 55 in Illinois with Interstate 65 in Indiana.
- **Sutton Lake Master Plan, Braxton County, West Virginia:** landscape architect responsible for developing a renovation master plan for the Sutton Lake Marina. The plan developed a new 300-slip, seasonal-user marina; a 107-slip day-use rental marina section; and re-designed the boater access, parking, and ramp areas. The plan also included main dock facility upgrades, including expanded houseboat and courtesy docks, addition of a floating restaurant with dock pod, a new restroom/changing building, a clothes washing facilities, rental equipment and storage building, maintenance building, offices, and a café deck. As a subconsultant, WSP developed a master plan for Sutton Lake, West Virginia. Future phases were to include preliminary engineering and associated tasks.
- **City of Lewisville Interstate 35 Corridor Aesthetic Design, Lewisville, Texas:** landscape architect for development of an 8-mile interstate highway corridor identity plan passing through the City of Lewisville. Todd prepared themed bridge and wall graphics and custom lighting, barrier, paving, and site furnishings to express the Parks, Old Town, and Lake area context of the community. The design included typical interchange and highway planting treatments and preparation of detailed cost estimates for all proposed enhancements. WSP provided aesthetic design services for the Interstate 35 Corridor in Lewisville.



CHARLES WARREN

Director, Real Estate Value Capture & Analysis



Years with the firm

7

Years total

23

CAREER SUMMARY

Charles Warren combines an academic background in city planning with seventeen years of commercial real estate experience. Dr. Warren focuses on innovating and delivering quantitative analysis to help optimize the structures and policies that effectively incite desired real estate redevelopment, maximizing the impact of transit-oriented development. This includes work enabling multiple and overlapping jurisdictions, such as transit providers, municipalities, and other agencies, to work together to leverage future increases in land value to enable new capital investment today.

Dr. Warren serves as a Commercial Real Estate Economics specialist extending WSP's capabilities into market forecasting, highest and best-use analysis, development economics, and project financial feasibility. His team helps clients take a realistic look at possibilities for job growth and new building in transit-oriented development zones, bringing forward hidden opportunities and pioneering ideas.

Previously, Dr. Warren was a partner at Heybrook West, a woman-owned business specializing in making Big Data analysis accessible to real estate investors, economic development agencies, and retail operators. Prior to that, he served as Director of Cushman & Wakefield's Retail Consulting practice, focusing on the strategic locating of stores, outlets, and distribution networks for retailers, including Crate & Barrel, Lacoste, TD Bank, and Ann Taylor/LOFT.

OTHER WSP EXPERIENCE

- **Hartford Line Transit-Oriented Development Action Plan, Hartford, Connecticut:** lead analyst for real estate market supply and demand forecasts and lead modeler of project financial feasibility. Dr. Warren delivered market forecasts and projections to create a frame for reasonable expectations of the types, amounts, and timing of future real estate redevelopment. He worked with a range of municipalities, from capital city to exurban/rural villages, customizing each model with ultra-local sales data and construction labor information. Dr. Warren developed pro forma models of commercial real estate development, identifying design, construction, and access reasons that desired housing types were not being constructed. He measured profit and loss to help towns understand the sizes and sources of financial gaps. Dr. Warren also identified appropriate sources from state and federal grant programs to close those gaps.
- **Jackson Street Reimagined Transportation Master Plan, Pensacola, Florida:** lead analyst conducting a market demand forecast and supporting the risk assessment of gentrification and displacement. Dr. Warren assessed the types, amount, and speed of local redevelopment to determine how quickly development pressures would affect the neighborhoods in the study area. He incorporated land elevation, coastal access, and estuary systems into a climate change gentrification threat analysis to show how flood displacement could generate sudden and intense demand for new development (and displacement) in neighborhoods previously considered less desirable.

PREVIOUS EXPERIENCE

Before joining WSP, Charles's experience included:

- **Amtrak Real Estate Asset Monetization Study, New York, Philadelphia, Baltimore, Chicago, and Washington, D.C.:** task leader responsible for delivering the highest and best-use analysis and development vision at five Amtrak-owned stations. Dr. Warren was the lead analyst for modeling revenue-generating scenarios, including adaptive reuse of stations and adjacent properties, incorporation of strategic acquisitions, and air rights transfers. Outputs were integrated into profitability models comparing capital structures



CHARLES WARREN

Director, Real Estate Value Capture & Analysis

(joint venture, public-private partnership, limited partnership, ground lease, air rights transfer, or outright sale) to identify paths forward that would maximize financial returns and raise capital the fastest.

- **D-O-LRT Station Planning Study, Durham and Chapel Hill, North Carolina:** developed highly detailed value capture cash flow forecasts based on new transit-oriented development envisioned in community workshops. Results were required for negotiating potential partnerships and taxation policies that would partially finance line construction involving two cities, two counties, two universities, one transit agency, and one municipal planning organization. Dr. Warren delivered a discounted cash flow analysis accompanied by an interactive Excel worksheet that allowed transit agency and municipal employees to change assumptions and automatically recalculate estimates.
- **Fort Worth High-Speed Rail Station Siting, Fort Worth, Texas:** performed and delivered an economic analysis to model the types of economic sectors and industries in the metro regions that would be transformed by high-speed rail service. Dr. Warren recommended a high-speed rail hub that would enable Fort Worth, the most affordable of the large Texas cities, an opportunity to overhaul and rejuvenate its downtown economic development program by connecting Austin's tech hub, Dallas's financial sector, and San Antonio's manufacturing specialties to each other, becoming a crossroads with affordable commuting across multiple growing employment areas.
- **North-South Streetcar Corridor Planning Study, Winston-Salem, North Carolina:** delivered a real estate development feasibility forecast for the downtown Winston-Salem streetcar corridor, including Wake Forest and Winston-Salem State campuses. Dr. Warren compared the market rent/sale values to local land and construction costs to measure the size and identify the causes of financial gaps. This analysis led to recommendations for funding sources, taxation policies, and entitlement reform that would most effectively boost new construction starts. He delivered recommendations on potential programs for gap funding.

PUBLICATIONS & PRESENTATIONS

Publications

- "Researching and Evaluating Market Opportunities: Trying a Two-Dimensional Approach," NAIOP, September, 2021
- "A New Look at Market Tier and Ranking Systems," NAIOP, March, 2020

Presentations

- "The Seven Suburbs," 2018 RailVolution, Pittsburgh, Pennsylvania, 2018
- "Getting It Dialed In: Trade Areas in Retail Spatial Analysis," 2011 Alteryx Inspire, Denver, Colorado, 2011



DUSTIN DAVIDSON, PE, CFM

Drainage Engineer



Years with the firm

4

Years total

7

CAREER SUMMARY

Dustin Davidson is an engineer located in WSP's Albuquerque, New Mexico offices, primarily focusing in drainage projects. Throughout his career, Dustin has gained proficiency in several engineering software programs, including Civil 3D, HEC-HMS, HEC-RAS, EMS, SMS/SRH 2D, and ArcGIS.

PREVIOUS EXPERIENCE

Before joining WSP, Dustin's experience included:

- **City of Albuquerque - Storm Drainage Project Manager, Albuquerque, New Mexico:** as a storm drainage project manager for the City of Albuquerque, Dustin's responsibilities included: - Overseeing transportation and storm drain projects of various sizes across the City of Albuquerque. - Applying engineering knowledge and standards to scoping, design, and construction phases. - Creating a HEC-RAS model from Civil 3D for Masthead Road Extension. - Reviewing submitted hydrologic and hydraulic models for storm drain projects. - Reviewing drainage reports for the Transportation Group. - Negotiating scope and fees for executed contracts. - Reviewing construction plans to ensure constructability and City of Albuquerque standards were met. - Coordinating with consulting firms to keep projects on schedule. - Designing small projects from City Council and the Mayor's Office, including infiltration trenches, valley gutters, storm drains, roadway restriping, medians, roadway widening, and speed tables/speed humps. - Managing on-call contract with WSP. - Negotiating scope and fees for on-call tasks. - Leading public meetings to obtain input from concerned citizens.
- **New Mexico Department of Transportation - Drainage Bureau Intern, New Mexico:** as an engineering intern for the New Mexico Department of Transportation Drainage Bureau, Dustin's responsibilities included: - Conducting drainage engineering hydrologic and hydraulic analyses. - Preparing preliminary and final drainage report for design and production for State Transportation Improvement Plan projects. - Coordinating with the New Mexico Department of Transportation Bridge Bureau early on in the design cycle to determine water surface elevations for use in bridge type selection reports. - Assisting various districts with any drainage related problem they may come across. - Worked closely with Bridge Bureau, Design Regions and Districts to get State Transportation Improvement Plan and local projects to production. - Aiding project development engineer in drainage related consultant scope. - Negotiating consultant scope and fees for on-call contracts. - Tracking consultant on-call contracts. - Issuing task orders to consultants. - Reviewing consultant work to ensure compliance with New Mexico Department of Transportation drainage criteria.



ANDREW SUTLIFF, PE

Project Engineer



Years with firm

5

Years of experience

7

Professional registrations

*Professional Engineer: NM,
2020 (26129)*

Education

*BS, Civil Engineering,
University Of New Mexico,
2015*

Professional memberships

*American Society Of Civil
Engineers, NM Section
Northern Branch Vice
President*

*American Council Of
Engineering Companies,
State Director*

CAREER SUMMARY

Andrew has served as a project and task manager with a proven track record for various municipalities throughout New Mexico. He leads our local New Mexico design team and assists with coordination between clients and subconsultants. Andrew brings a passion for client service and a drive to champion innovative methods for coordinating with project teams and stakeholders.

SELECTED PROFESSIONAL EXPERIENCE

Access Controlled Highways

- New Mexico Highway 528 Rio Rancho Phase 2 Final Design Services, Rio Rancho, New Mexico

Airside Facilities

- On-Site Airfield Safety Enhancements (ASE) Program Management (PM)/Construction Management (CM) Services, Tucson Airport Authority,, Tucson, Arizona
- Dallas Fort Worth Airport On-call Airfield Design Services, Dallas, Texas

Bus Rapid Transit (Brt)

- MRCOG 2017 Rio Metro 2017 On-Call Planning Services, Albuquerque, New Mexico

Drainage

- WOODWARD ROAD & 2ND STREET IMPROVEMENTS, Albuquerque, New Mexico
- New Mexico Department of Transportation On-Call Drainage Services and Scour Analysis, New Mexico
- NMDOT 2017 On-Call Drainage Services, New Mexico

Information Sharing Sys (Its)

- City of Albuquerque 2015 Regional Transportation Management Center Planning Services, Albuquerque, New Mexico

Infrastructure For Buildings

- Santa Clara City Center Program Management, Santa Clara, California

Intercity/High Speed Rail

- Amtrak Americans with Disabilities Act Stations Program, Philadelphia, Pennsylvania

Medium And Short Span Bridges

- CIBOLA COUNTY ROAD 5 BRIDGE REPLACEMENT, Moquino, New Mexico
- NMDOT CN6100838 - 1-40 MP 105.9-106.4 Bridge Rehab Phase 1, Cubero, New Mexico



ANDREW SUTLIFF, PE

Project Engineer

- Village or Ruidoso 2021 Bridge Replacement Final Design, Ruidoso, New Mexico
- New Mexico Department of Transportation 2020 Statewide On-Call Bridge Design and Inspection Services, New Mexico
- New Mexico Department of Transportation NM 566 Historical Bridge Replacement, Milan, New Mexico
- New Mexico Department of Transportation 2018 On-Call Statewide Bridge Services, New Mexico
- New Mexico Highway 6 Rio Grande Bridge Design Services, Los Lunas, New Mexico

Passenger Termin/Control Tower

- City of Albuquerque On-call Aviation Project Management Services, Albuquerque, New Mexico

Pedestrian Bridges

- New Mexico Department of Transportation Tramway Pedestrian Bridge Rehabilitation, Albuquerque, New Mexico

Surface Streets And Roads

- CIBOLA COUNTY TRAFFIC COUNTING - 202305300, Cibola County, New Mexico
- NMDOT NRD/SRD GEN ENG ON-CALL 2022-2025, New Mexico
- 98th and Benavides Intersection Improvement, Albuquerque, New Mexico
- City of Albuquerque 2021-2023 On-Call Citywide Transportation and Storm Drainage Services, Albuquerque, New Mexico
- Statewide General Engineering On-Call 2020, New Mexico
- CORR Standard Details and Drawings 2020, Rio Rancho, New Mexico
- City of Santa Fe 2020 On-Call Design Services, Santa Fe, New Mexico
- New Mexico Department of Transportation NM 128 and NM 31 Design-Build Project Management Services, Eddy & Lea County, New Mexico
- City of Albuquerque 2020 On-Call Transportation and Storm Drainage Services, Albuquerque, New Mexico
- New Mexico Department of Transportation Rio Bravo Boulevard Bridge Replacement, Albuquerque, New Mexico
- New Mexico Department of Transportation U.S. Route 380 Alignment Study, Roswell, New Mexico



ANDREW SUTLIFF, PE

Project Engineer

- New Mexico Department of Transportation Cerrillos Road Alignment Study, Santa Fe, New Mexico
- New Mexico Department of Transportation Statewide On-Call General Engineering Services, New Mexico
- New Mexico Department of Transportation U.S. Route 64 Phase A/B/C/D, Albuquerque, New Mexico
- City of Albuquerque On-Call Transportation and Storm Drain Design Services, Albuquerque, New Mexico
- NMDOT 2018 I-25/Rio Bravo Phase 2 Reconstruction Design, Albuquerque, New Mexico
- City of Albuquerque 2017 On-Call Transportation and Drainage Services, Albuquerque, New Mexico
- New Mexico Department of Transportation 2016 Roadway and Intersection Improvement Design Services, Albuquerque, New Mexico
- New Mexico Department of Transportation On-Call Traffic Engineering Services, New Mexico
- Ladera Drive Widening Design Services, Albuquerque, New Mexico
- Bernalillo County 2014 On-Call General Engineering Services, Bernalillo County, New Mexico
- Interstate 25/Rio Bravo Interchange Design Services, Albuquerque, New Mexico

Traffic Engineering

- City of Albuquerque West Central Avenue Complete Streets Improvements, Albuquerque, New Mexico
- Bernalillo County 2019 On-Call Engineering Services, Albuquerque, New Mexico

Underground Mining

- FMI-Tyrone/EMMA Permit Sppt/NM, Grant County, New Mexico



JAMES HEIMANN, PE, PTOE

Traffic Engineering And Planning



Years with firm

19

Years of experience

34

Professional registrations

Professional Engineer: NM,
1994 (12418)

Professional Traffic
Operations Engineer: US,
2001 (724)

Education

MS, Civil Engineering,
University Of Nebraska-
Lincoln, 1989

BS, Civil Engineering,
University Of Nebraska-
Lincoln, 1988

Professional memberships

Institute Of Transportation
Engineers

Publications and presentations

Heimann, James. "Effect of
Driveway Traffic on
Saturation Flow Rates at
Signalized Intersections"
ITE Journal, February, 1990

Heimann, James. "School
Speed Limits and Speeds
in School Zones"
Transportation Research
Record, 1990

CAREER SUMMARY

James "Jim" Heimann has diverse experience in the evaluation and development of transportation improvement projects, from the study phase through final design. He has provided his expertise to city, county, and state agencies. Jim has served as project manager on various types of projects and has the experience and knowledge to lead multi-disciplinary teams.

Jim has been involved in urban transportation projects, including corridor/alignment studies, scoping studies, traffic operations studies, safety studies, feasibility studies, subarea planning studies, regional planning studies, environmental assessments, bicycle planning studies, and design projects. His project experience has provided him with extensive knowledge of transportation systems and with an awareness of the important role stakeholder involvement plays in the development of transportation projects.

Jim's transportation design experience includes roles as a project engineer in traffic design aspects and as a project manager for the development of construction plans for urban street improvements. His conceptual design experience includes streets and intersections; complete streets, including bicycle, pedestrian, and transit; and interstate highways and interchanges. His preliminary and final design experience includes developing construction plans for signing and striping, roadway and intersection lighting, and traffic signals. Jim has prepared bid documents and provided construction phase services for City of Albuquerque projects.

SELECTED PROFESSIONAL EXPERIENCE

Access Controlled Highways

- NMDOT 2015-2017 Design Manual Development Services, New Mexico
- New Mexico Highway 528 Rio Rancho Phase 2 Final Design Services, Rio Rancho, New Mexico
- NMDOT 2014-2016 Long-Range Transportation Planning Services, New Mexico
- South Interstate 25 Corridor Study, Albuquerque, New Mexico
- Valencia County 2011-2013 Manzano Expressway Design Services, Albuquerque, New Mexico
- New Mexico Route 528 Rio Rancho Design Services, Albuquerque, New Mexico
- City of Albuquerque 2010-2014 On-Call Engineering Services, Albuquerque, New Mexico
- Interstate 25 North Corridor Study, Albuquerque, New Mexico
- NMDOT 2006-2010 On-Call Statewide Environmental Services, Santa Fe, New Mexico
- City of Santa Fe 2006 Railyard Offsite Signal Improvement Design, Santa Fe, New Mexico



JAMES HEIMANN, PE, PTOE

Traffic Engineering And Planning

- Cerrillos Road Phase 2 Reconstruction Design Services, Santa Fe, New Mexico
- Interstate 40 Reconstruction Design Services, Albuquerque, New Mexico
- NMDOT US 84/285 (Pojoaque to Española) Design Services, Pojoaque, New Mexico
- NMDOT US 285 Clines Corner Study, Albuquerque, New Mexico
- NMDOT Paseo Del Volcan Corridor ROW Services, Albuquerque, New Mexico

Bus Rapid Transit (Brt)

- RMRTD UNM/CNM/Sunport Transit Study, Albuquerque, New Mexico

Commuter Rail

- Rail Runner Consulting Services, Santa Fe, New Mexico

Drainage

- New Mexico Department of Transportation 2020 On-Call Traffic Engineering Services, Deming, New Mexico

Interchanges

- NMDOT I-25/Montgomery Blvd Interchange Reconstruction Design, Albuquerque, New Mexico
- Interstate 25 Canoncito Study Planning Services, Santa Fe, New Mexico
- Mesa del Sol Interchange Final Design Services, Albuquerque, New Mexico
- Interstate 25 Paseo Del Norte Interchange Reconstruction Design Services, Albuquerque, New Mexico
- Interstate 40/Coors Interchange Reconstruction Design Services, Albuquerque, New Mexico

Medium And Short Span Bridges

- NMDOT NM 574 La Plata River Design Services, Albuquerque, New Mexico
- New Mexico Department of Transportation 2018 On-Call Statewide Bridge Services, New Mexico
- NMDOT 2016 Bridge ROW Mapping Services, Albuquerque, New Mexico
- New Mexico Highway 6 Rio Grande Bridge Design Services, Los Lunas, New Mexico
- NMDOT 2014 Clines Corner Interchange Design Services, Albuquerque, New Mexico



JAMES HEIMANN, PE, PTOE

Traffic Engineering And Planning

Multimodal

- Mid-Region Council of Governments 2021-2023 On-Call Advisory Services, Albuquerque, New Mexico

Other

- High Capacity Transportation Study Alternatives Analysis, Albuquerque, New Mexico
- Main St. 2011-2014 General Engineering Services, Albuquerque, New Mexico
- LANL Planning and Engineering Services
- Ruidoso Area Transportation Network Study, Ruidoso, New Mexico
- Bernalillo County 2007-2011 On-Call Engineering Services, Albuquerque, New Mexico
- Bernalillo County Phase II Edith Boulevard Reconstruction Design, Albuquerque, New Mexico
- NMDOT Espanola Relief Route Study, Albuquerque, New Mexico
- Bernalillo County Edith Boulevard NE Reconstruction Design, Bernalillo County, New Mexico

Pedestrian Bridges

- Utah Valley University Pedestrian Bridge Over Interstate 15 Design Services, Orem, Utah

Roadside Aesthetics

- New Mexico Department of Transportation Statewide Engineering On-Call Projects, New Mexico

Streetcar/Trolley/Tramway

- ABQ Ride Daytona Design Services, Albuquerque, New Mexico

Surface Streets and Roads

- NMDOT D5 - CN5101174 - US 64, MP 0-20, PHASE II SERVICES, Shiprock, New Mexico
- City of Albuquerque 2021-2023 On-Call Citywide Transportation and Storm Drainage Services, Albuquerque, New Mexico
- Statewide General Engineering On-Call 2020, New Mexico
- STREETLIGHT DATA NM 31/128+, Albuquerque, New Mexico
- City of Santa Fe 2020 On-Call Design Services, Santa Fe, New Mexico



MOHIT ATHASNIYA, PE

Sr. Consultant, Structural Engineer



Years with the firm

4

Years total

4

Professional registrations

*Professional Engineer:
NM (25974)*

CAREER SUMMARY

Mohit Athasniya is an engineer located in WSP's Santa Fe, New Mexico office, with structural design experience including steel bridge design, analysis, and rating. He has worked on a variety of bridge replacements/rehabilitation projects. Prior to joining the firm, Mohit worked as a structural designer in Pennsylvania. He worked on a variety of bridge projects, which consisted of bridge rehabilitation contracts, temporary bridge design contract, a new bridge construction contract, and miscellaneous other structural repairs. Working as a design consultant for contractors required frequent and prompt modification to the design and drawings in order to expedite the construction process and meet the deadlines. Apart from frequent changes, due to heavy volume of traffic across Pennsylvania, most of the rehabilitation project Mohit worked on had to be designed in multiple construction stages without affecting the traffic flow. Throughout his career, Mohit has gained proficiency in several engineering software programs, including BRASS Girder, AutoCAD, ABLRFD, SAP, BAR7, PSLRFD, spColumn, STAAD, SupportIT, MicroStation, CANDE, CSI Bridge, MathCAD, MTS, Instron, ProjectWise, and Bluebeam.

OTHER WSP EXPERIENCE

- **Bridge over Cooks Creek Replacement, Bucks, Pennsylvania:** responsible for designing the excavation support system using sheet piles, compression struts, and soil anchors for construction of the footing and abutment of new bridge using SupportIT software. Mohit also monitored masonry walls adjacent to excavation shoring system during pile driving and construction of bridge abutments.
- **Maryland Department of Transportation - Purple Line Light Rail Project, Maryland:** as the structural reviewer on this project, Mohit was responsible for reviewing design and drawings of concrete abutments for a temporary bridge on deep foundation.
- **Nevada Department of Transportation - Bridge Load Rating (Task II), Nevada:** as structural designer, Mohit responsible for performing bridge load ratings for various multi-span steel, reinforced concrete, prestressed concrete, prestressed box girders, and reinforced arch culverts for emergency vehicles. He assisted the senior bridge engineer in inspection of bridge deck panels. Mohit also verified reinforcement, cover, bar size, and location of the bridge rail post in accordance with the contract plans.
- **New Mexico Department of Transportation - Interstate 40 Bridge Pier Protection, Newkirk, New Mexico:** responsible for reviewing 54-inch concrete wall barrier for conformance with contract. Mohit also developed reinforcement and schedule for 54-inch concrete wall barrier.
- **New Mexico Department of Transportation - New Mexico Highway 93 over Interstate 40 Bridge Rehabilitation, Glenrio, New Mexico:** responsible for inspecting multiple precast bridge deck panels. Mohit also verified reinforcement, bar size, and locations of the bridge rail post in accordance with the contract drawings.
- **Pennsylvania Department of Transportation - Chester Valley Trail Project (Phase IV), Chester, Pennsylvania:** as the structural designer, Mohit was responsible for designing and detailed drawings of reinforced cement concrete abutments on pile and open foundations for a steel truss bridge using the Pennsylvania Department of Transportation's Abutment and Retaining Wall Analysis and Design Program. He also designed a 180-foot-long cantilever retaining wall, performed site inspections of an existing three-cell box culvert, and prepared a structural assessment report determining structural stability of culvert.
- **Pennsylvania Department of Transportation - Chestnut Street at 30th Street Rehabilitation, Philadelphia, Pennsylvania:** responsible for designing and detailing the temporary shoring support system using wooden columns for supporting the three-span



MOHIT ATHASNIYA, PE

Sr. Consultant, Structural Engineer

arch bridge. Mohit proposed the demolition plan of the Schuylkill River Bridge Deck, as well as design of temporary steel and wooden brackets to support the new bridge deck and sidewalk. He also designed the temporary walkway for emergency exit using steel beams, existing corbels, and providing installation methodology. Mohit was also responsible for designing and providing drawings of temporary shoring support system using wooden columns for supporting two-span arch bridge per the National Design Specification Wood Design Manual.

- **Pennsylvania Department of Transportation - Rapid Bridge Replacement Public Private Partnership, Pennsylvania:** this project was designed to bolster the Pennsylvania Department of Transportation's on-going effort to address the state's nearly 4,200 structurally deficient bridges. Mohit was responsible for performing detailed structural calculations and reviewing 20 precast concrete box culverts from different contractors using the Pennsylvania Department of Transportation's Box Culvert Design and Rating Program. He also confirmed the type, size, and location plans using AutoCAD 2016 and reviewed the structural reinforcement provided. Mohit's additional responsibilities included performing detailed review of construction drawings of abutment panels, performing detailed segmental post-tensioning calculations and methodology, and lifting and installing precast box culverts as per Pennsylvania Design Manual Part 4-2015 Edition and American Association of State Highway and Transportation Officials Load and Resistance Factor Design-2014 Edition.



CHRIS NAIDU, PE
NM Water Team Lead



CAREER SUMMARY

Chris Naidu has 13 years of experience in drainage and flood control projects throughout New Mexico. Over the last 13 years, he has worked on drainage and flood control projects that include analysis and design of complex drainage systems, preparation of drainage master plans, preliminary and final design, and construction plans for small dams, open channels, grade control structures, erosion and energy dissipators, storm drains and miscellaneous drainage structures. Chris excels in developing hydrologic numerical models for watersheds both rural and urban using advanced geospatial analysis techniques which not only produce cutting edge models, but also reports and maps that provide an innovative resource for funding acquisition and planning. In addition to hydrologic modeling, he has extensive experience in hydraulic analysis of natural riverine systems, manmade channels, storm drain networks and various other conveyance systems.

Years with the firm

<1

Years total

13

Education

*BSc in Civil Engineering,
University of New
Mexico, 2010*

Professional Memberships

*New Mexico Watershed
& Dam Owners
Coalition*

*New Mexico Floodplain
Managers*

Chris has analyzed scour criticality for large culvert crossings, bridges, and sediment transport capacity of arroyos. He is proficient in construction of two-dimensional (2D) surface water models that predict flow paths of complex stream networks using advanced GIS based tools. Using the animations and interactive animations from the various models, Chris has successfully communicated and coordinated critical planning and design project elements with clients, review agencies and local communities. His projects often require public engagement and interacting with communities to help them understand not only the technical analysis involved with drainage projects but also the importance and need for flood control projects for the safety of various local communities throughout New Mexico.

EXPERIENCE PRIOR TO WSP

Alameda Drain Study, Albuquerque, New Mexico

The Alameda Drain Study was a drainage master plan that covered 17 square miles in the City of Albuquerque and extended incorporated areas of the Bernalillo County area. The purpose of the study was to determine the hydraulic capacity of the Alameda Drain, which is a waste way for irrigation water. The drain also receives storm water runoff from the adjoining watershed. The study developed a composite hydrologic and hydraulic model in PCSWMM that modeled over 20 miles of storm drain, detention facilities amounting to over 600-acre feet of storage, and 5 pump stations within the watershed. Specific modeling parameters for valley conditions were developed for areas that were depressed in valley areas. The project provided the Bernalillo County a good estimate of capacity in the drain, structures and channel areas that were under capacity and recommendations on next steps for improvement in areas identified as highest priority. Total project budget was \$530,000.

San Mateo to Moon Mini Drainage Master Plan, Albuquerque, New Mexico

This urban drainage master plan was developed for Albuquerque Metropolitan Arroyo Flood Control Authority (AMAFCA). This study covered 4.6 square miles in the highly urbanized northeast part of Albuquerque that has historically flooded severely. The study developed a hydrologic model using HEC-HMS to compute runoff rates and volumes. Once problematic areas were identified, several public meetings were held to correlate modeling results to actual events based on public input. Proposed improvements were then developed to mitigate the flooding issues. The study has become the master planning document to guide future drainage improvements in the watershed. Project cost was approximately \$225,000.

Mid Valley Drainage Master Plan, Albuquerque, New Mexico

The Mid Valley Drainage Master Plan was developed for the City of Albuquerque to study the downtown Albuquerque area. The study area covering 4.1 square miles, relies on stormwater pump stations to drain the watershed as the area is lower in elevation than the Rio Grande. Significant flooding problems have occurred due to old infrastructure, and the study identified improvements



CHRIS NAIDU, PE

NM Water Team Lead

for the most critical areas. All analysis was developed in EPA SWMM since the area was very flat and valley hydrology methods needed to be applied to account for higher initial abstractions than that of a typical watershed. Project cost was approximately \$300,000.

Marble Arno Storm Drainage Improvements, Albuquerque, New Mexico

This project was developed in the Mid Valley Drainage Master Plan and is a great example of good planning and well documented drainage studies. Construction for this jointly funded project by City of Albuquerque and AMAFCA, was completed at the final cost of 17 million dollars in 2022. The project involved design and construction of a new 47,000 gallons per minute storm water pump station, installation of large diameter storm drains ranging from 42–66-inch diameter storm drain, roadway improvements, and installation of new inlets to improve capture capacity of surface runoff.



1. STAFF ALLOCATION FOR LABOR

Staff	Hourly Rate
Dan Baer	\$529
Manjeet Ranu	\$430
Aron Kirsch	\$428
Peter Waldt	\$347
Ronald Roberts	\$292
Jenifer Ross-Amato	\$292
Mark Montgomery	\$282
Judah Gluckman	\$253
John Loughran	\$252
Chris Naidu	\$247
Sam Spencer	\$241
Jim Heimann	\$231
Ray Trujillo	\$233
Tim Thornton	\$231
Charles Warrant	\$228
Adnrew Piana	\$209
Amy DiCarlantonio	\$199
Jennifer Hyre	\$196
Andrew Sutliff	\$184
Heather Martin	\$179
Todd Teuscher	\$165
Dustin Davidson	\$159
Miranda Braatz	\$152
Nick Fazio	\$131
Mohit Athasniya	\$127

Subject to annual adjustments

Pursuant to Cooperative Educational Services terms, a 1.25% administrative fee must be added to the above rates and fee.

Services provided are billed time and materials, not to exceed authorized amount.

2. SUBCONSULTANTS

Billed at Cost

3. DIRECT EXPENSES (At Cost)

Mileage (Federal Funding)	\$0.655 per mile (or current IRS rate)
Per Diem	\$85 per diem (\$135 high cost area - Santa Fe)
Printing and other direct expenses	Billed at Cost



CITY OF ALBUQUERQUE ABQ RIDE UPTOWN TRANSIT CENTER

LOCATION

Albuquerque, NM

CLIENT

City of Albuquerque's Transit Department (ABQ Ride)

PROJECT DESCRIPTION

WSP led the effort in assisting the City of Albuquerque's Transit Department (ABQ Ride) in obtaining a \$25 million federal RAISE grant for a Joint Development of the Uptown Transit Center. This is an exciting joint development project set to transform a 3-acre parcel in the city's busiest employment, shopping, and entertainment district. This innovative project will breathe new life into the current park-and-ride lot, transit transfer platform, and private credit union, creating a vibrant mixed-use development that's a perfect blend of affordable and market-rate apartments, retail spaces, and a reimagined transit plaza at its heart.

Phase I, made possible by the RAISE award, focuses on transforming the transit center into a dynamic plaza. With a 100-foot width, it will feature 6 bus docks, covered waiting areas, benches, lighting, and pedestrian amenities. Additionally, there will be 22,000 sq. ft. of commercial space and two underground parking levels with 402 spaces. Rest assured, existing bus services will continue uninterrupted during this phase. Phase II elevates the project even further, with a striking seven-story tower housing 215 affordable housing units, alongside 19 apartments on the transit plaza, catering to market-rate housing or short-term rentals. This phase seamlessly integrates with the transit plaza, fostering a vibrant community experience. Finally, Phase III marks the completion of the development with a private 1-acre expansion, featuring 194 market-rate dwelling units and over 6,000 square feet of commercial space. The start of this phase awaits the successful completion of Phases I and II, due to the necessary demolition of the existing credit union.

WSP assisted ABQ Ride in developing its vision rooted in innovation, convenience, and community-building, that will culminate in a bustling hub that enriches the local area and creates a compelling destination for residents and visitors alike.



Before



After (Conceptual)



MOYNIHAN TRAIN HALL & FARLEY BUILDING REDEVELOPMENT



LOCATION

Manhattan, NY

CLIENT

New York State Empire State Development (ESD)

PROJECT VALUE

\$1.6 Billion

SIZE

1.1 Million SF (Train Hall & Retail/Office)



PROJECT DESCRIPTION

Set below Madison Square Garden and Penn Plaza, today's New York Penn Station welcomes close to 75 million Amtrak, and Long Island Rail Road (LIRR) passengers to Manhattan each year into a confined, crowded, poorly lit environment. In an effort to recreate the grand entrance to the City lost when the original Penn Station was demolished, Empire State Development (ESD), New York State's economic development authority, is dramatically reconfiguring the James A. Farley Post Office Building, which sits 50 feet above Penn Station's train platforms, to create the Moynihan Train Hall.

Since 1991, WSP has worked with ESD, Amtrak, the U.S. Post Office, developers Related and Vornado, and countless other stakeholders to develop plans for and achieve consensus on key issues like station operations and pedestrian circulation. And our work has touched almost every piece of this program. We've analyzed the tradeoff of transportation service and revenue objectives and have provided funding and financing advisory services. We've also served as a technical liaison on rail operations issues and have designed some of the station elements, including the platform ventilation systems.

Work on Phase 2 of the project, which will transform the Farley Building into a grand transit hall for LIRR and Amtrak passengers and provide 750,000 sq. ft. of retail and office space, began in the spring of 2017. WSP continues its involvement in the project by providing program management services during Phase 2 construction.



HUDSON YARDS REDEVELOPMENT



LOCATION

Manhattan, NY

CLIENT

Hudson Yards Development Corporation

PROJECT VALUE

\$23 Billion

SIZE

40,000,000 SF (Residential/Office/Commercial)

PROJECT DESCRIPTION

The West Side of midtown Manhattan has long been defined by the Hudson Yards: a rail storage and layover facility for New Jersey Transit and Long Island Rail Road. Various initiatives focused on overbuild of the 28-acre Hudson Yards came and went, with no appreciable results... until now.

As WSP developed environmental documentation and preliminary and final engineering for an ambitious extension of the No. 7 line subway that would connect the Midtown West Side to the City's subway system, the prospects for development dramatically improved. Transit connectivity provided the foundation for the largest private development in the history of the United States - the addition of more than 40 million square feet of residential, office, and commercial space.

WSP's environmental and planning studies helped to advance the rezoning of the Yards that would underpin the value capture financing strategy used to fund the construction of the deck above the rail yard. WSP also developed the construction plan, performed utility surveys, conducted intensive geotechnical explorations, and coordinated with myriad utilities and stakeholders (including Amtrak) and the public. Above the deck, we served as structural and building systems engineers for many of the skyscrapers towering over the site, including a 41-story office building, a 66-story mixed-use building, and a 70-story residential high rise.



BURNHAM YARD REDEVELOPMENT

LOCATION

Denver, CO

CLIENT

State of Colorado Department of Personnel & Administration (P3 Unit)

PROJECT DESCRIPTION

The Burnham Yard Redevelopment project presents a significant opportunity to realize Burnham Yard’s mobility and development potential—to take it from an underutilized parcel to a centrally located asset with far-reaching benefits. This development will be advanced in concert with the proposed existing rail realignments, planning to accommodate future rail, and the National Environmental Policy Act (NEPA) process that will provide improved operational efficiencies and opportunities for increased passenger connectivity. These actions will be developed and refined through an extensive outreach process that engages the full range of partners, stakeholders and public groups.





POTOMAC YARD

METRO RAIL STATION VALUE CAPTURE ANALYSIS

LOCATION

City of Alexandria, VA

PROJECT DESCRIPTION

For over 10 years, WSP assisted the City of Alexandria, Virginia, with developing and implementing a strategy to pay for a new Metrorail station adjacent to a rapidly developing former rail yard. The city did not have the funds necessary to pay for a new station. However, the planned redevelopment of the Potomac Yard area represented a rare opportunity for large-scale, mixed-use, infill development within close proximity to the core of the Washington, DC region. As such, there was potential to tap into the value created by this development, but the city needed to know how best to do that.

Our analysis demonstrated that the right mix of value capture techniques, which included development impact fees, tax increment financing, and special assessments, could provide an effective means of harnessing the benefits of future development at Potomac Yard. We worked with numerous stakeholders, including the city's planning department and tax assessor's office, Washington Metropolitan Area Transit Authority (WMATA), and private sector developers and landowners in the surrounding area to ensure assumptions and inputs to the financial analysis facilitated realistic forecasts of land use and development planning and the resulting revenue-generating potential that could be used to help pay for the station.

The analysis included revenue from residential, office, retail, and hospitality land uses, incorporating the city's applicable taxes and fees. We also structured our financial model to provide results for four different station locations, incorporating varying station costs and development scenarios in each. Through a combination of two tiers of special district taxes, net new tax revenues from development, and developer contributions from construction within a quarter-mile from the station, our analysis showed the \$320 million station could be financed solely on the revenue generated by the nearby development without any impact on the city's existing tax base.

This analysis was used to support negotiations of a memorandum of understanding with the landowner that resulted in an agreement by the developer for a \$50 million contribution to the project. Both the financial plan and developer agreement were approved by the City of Alexandria Planning Commission and City Council, laying the groundwork for the redevelopment of this former rail yard into a modern, mixed-use urban center. Since then, WSP has provided the city with ongoing support, including revised financial forecasts based on more defined development plans in the area, factoring in ongoing changes in market values and new development. We also provided support for specific city tasks upon request, including assistance with a Transportation Investment Generating Economic Recovery (TIGER) grant application and analysis to support an application for a \$50 million loan from the Virginia Transportation Infrastructure Bank (VTIB), which the city successfully obtained.



The City held a groundbreaking ceremony in December 2019, and City Manager Mark Jinks thanked WSP specifically in his presentation: "The challenge was, when you build a station, you write the check up front; but you don't get that money from the tax revenues until 10, 20, 30 years from now. That created a cash flow problem. We had expert assistance from WSP. They developed the financial model and kept with us for a decade while we worked through each of the challenges as the station became more expensive, and as we tackled how we can put the pieces together."



WSP Helps Clients Achieve More

Through a combination of innovative thinking, leveraging best-practices in the industry, and reaching across the full spectrum of project development services, WSP delivers planning that adds value for our partner agencies and developers. WSP is a multidisciplinary strategy, planning, design, delivery and management consultancy that develops creative, comprehensive and sustainable solutions for a future in which society and our planet can thrive. Equipped with an intimate understanding of local intricacies, world-class talent and proactive leadership, we enable long-lasting and impactful solutions to uniquely complex opportunities and problems. *We are here to support your success.*



City of Santa Fe

Summary of Contract, Agreement, Amendment & Lease

All applicable fields to be completed by department (complete 1.b only if you are processing an amendment):

1.a Munis Contract: 3204300 Procurement # (RFP/ITB# If any):

Contractor: WSP USA, Inc.

Procurement Method/Vehicle: Small Purchase RFP ITB Sole Source GSA Cooperative Exempt SWPA/Existing

Description/Title: Provide the City with Owner's Representative Services to Implement the Infrastructure of the Redevelopment of Midtown Campus.

Contract: Agreement: Lease/Rent: Amendment:

Term Start Date: TBD Term End Date: 12/31/2028 Total Contract Amount: \$4,000,000.00

Approved by Council (If over the City Manager's approval threshold, you must go through GB) _____

Contract / Lease:

1.b Amendment #: 1 to the Original Contract/Lease # 3204433

Increase/(Decrease) Amount \$: 3,910,000.00

Extend Expiration Date to: 12/31/2028

Approved by Council (If the original went through GB, all amendments must go through GB regardless of the amendment reason) Date: _____

Amendment is for:

2. HISTORY of Contract, Amendments & Lease / Rent - Please Elaborate (option: attach spreadsheet if multiple amendments)

3. Procurement History: CES 2023-01-C211-ALL

Purchasing Officer Review: _____ Date: Apr 9, 2024
 Comment & Exceptions: _____

4. Funding Source: Midtown CIP MTC245250D-Design Org / Object: 5250610/572960

Andy Hopkins Budget Officer Approval: _____ Date: Apr 8, 2024
 Comment & Exceptions: _____

5. Grant History (if applicable): _____

Grants Administrator Approval: _____ Date: _____

Staff Contact who Completed This Form: Tim Farrell Phone #: 505-490-1659

To be recorded by City Clerk: _____ Email: tgfarrell@santafenm.gov

Clerk # _____
 Date of Execution: _____

ITT Representative (attesting that all information is reviewed)	Title	Date
---	-------	------

CITY OF SANTA FE PROCUREMENT CHECKLIST



Contractor Name: WSP USA, Inc

Procurement/contract Title: Owner's Representative Services for Midtown

Procurement Method/Vehicle: Sole Source State Price Agreement/Existing Cooperative Request For Proposals(RFP) Invitation To Bid (ITB) Exempt: 13-1-98
 Small Purchase (Contract Under \$60,000) Other: _____

Requesting Department: Public Works/ Facilities Div Staff Name: Tim Farrell

Procurement Requirements:

Procurement files shall be maintained for all purchases and contracts, regardless of the method of procurement. The procurement files shall contain the basis on which the awards are made, all submitted bids/proposals, all evaluation materials (bid tabs or Evaluation Committee Reports), scoresheets, quotations, and all other documentation related to or prepared in conjunction with evaluations, negotiations, and the award processes. The procurements shall contain written determinations from the Requesting Departments, signed by the Chief Procurement Officers (this document), setting forth the reasoning for the contract award decisions before submitting them to the Committees.

REQUIRED DOCUMENTS FOR APPROVAL BY PURCHASING (CPD)

YES	N/A		YES	N/A	
<input checked="" type="checkbox"/>	<input type="checkbox"/>	Written Determination (srvs)	<input type="checkbox"/>	<input checked="" type="checkbox"/>	Quote(s) (3 Valid & Current for Over 20k)
<input type="checkbox"/>	<input checked="" type="checkbox"/>	RFP - Confidential info to be provided to GB by CPD Buyer	<input type="checkbox"/>	<input checked="" type="checkbox"/>	BAR
<input type="checkbox"/>	<input checked="" type="checkbox"/>	ITB (include bid tab)	<input type="checkbox"/>	<input checked="" type="checkbox"/>	FIR
<input type="checkbox"/>	<input checked="" type="checkbox"/>	Other: _____	<input type="checkbox"/>	<input checked="" type="checkbox"/>	Certificate of Insurance (srvs)
<input checked="" type="checkbox"/>	<input type="checkbox"/>	Cooperative Agreements and GSAs and Statewide Price Agreements (include the cover page to show valid date, s page, and items to be purchased)			
<input checked="" type="checkbox"/>	<input checked="" type="checkbox"/>	Horizon Declination or Screenshot of horizonsofnewmexico.org/services.html (srvs)			
<input checked="" type="checkbox"/>	<input type="checkbox"/>	Summary of Contract (only on contracts)			
<input checked="" type="checkbox"/>	<input type="checkbox"/>	Current Santa Fe Business Registration (or Exemption if no tax)			
<input checked="" type="checkbox"/>	<input type="checkbox"/>	Executed Contract or Price Agreement (legal and contractor must sign before purchasing approves)			
<input type="checkbox"/>	<input checked="" type="checkbox"/>	Chief Procurement Officer (or designee) Approval for Exempt from Procurement (use memo on our site)			
<input type="checkbox"/>	<input checked="" type="checkbox"/>	Evaluation Committee Report (RFPs only)			
<input type="checkbox"/>	<input checked="" type="checkbox"/>	Signed Sole Source Determination, Vendor Written Quote, SS Letter from Contractors, and 30 Days Email			
<input type="checkbox"/>	<input checked="" type="checkbox"/>	>20k = Memo addressed to City Manager (Under 150K) Committees/City Council (Over 150K)			

Tim Farrell

Department Point of Contact

Regina Wheeler
Regina Wheeler (Apr 8, 2024 09:54 MDT)

Department Director

[Signature]

Chief Procurement Officer

ITT Representative

Property Development Manager

Title _____

Date _____

Date _____

Apr 9, 2024

Date _____

Title _____

Date _____

Item #: 24-0112

Munis Contract #: ~~3204433~~
3204300

CES Contact#: 2023-01-C211-ALL

CITY OF SANTA FE

PROFESSIONAL SERVICES CONTRACT

THIS CONTRACT is made and entered into by and between the City of Santa Fe, New Mexico, hereinafter referred to as the “City,” and **WSP USA, Inc.**, hereinafter referred to as the “Contractor,” and is effective as of the date set forth below upon which it is executed by the Parties.

RECITALS

WHEREAS, the Chief Procurement Officer of the City has made the determination that this Agreement is in accordance with the provisions of the New Mexico Procurement Code (NMSA 1978, 13-1-28 et seq.) pursuant to NMSA 1978, section 13-1-135; and

WHEREAS, the Contractor is one of such requisite and qualifications and is willing to engage with the City for professional services, in accordance with the terms and conditions hereinafter set out, and the Contractor understanding and consenting to the foregoing is willing to render such professional services as outlined in the Agreement.

The City and the Contractor hereby agree as follows:

1. Definitions

Infrastructure: The services and facilities that support a built environment, including but not limited to: utilities including water, waste water/sewer, surface and stormwater management and drainage, electricity, natural gas, and telecommunications including Internet access; all components of public rights of way including roads, bicycle and pedestrian paths, sidewalks, trails, parking, lighting, traffic signals, and property entrances; parks, open spaces, civic spaces, and fixtures therein (e.g., child play structures, public seating).

Predevelopment: Phase of project between establishing the Master Plan and Development Plan and entering into development agreements and initiating design of infrastructure. Considers various aspects and risks and focuses on financing and identifying steps to prepare for development activities.

2. Scope of Work

The purpose of the Owner’s Representative services described in this scope of work is to assist

and represent the City of Santa Fe to establish and oversee an ongoing programmatic approach to implement the Infrastructure of the Midtown Master Plan and Community Development Plan (“Project”).

The redevelopment of the Santa Fe Midtown Site (“Site”) includes a goal of advancing sustainable, resilient, and regenerative development, while creating green infrastructure that serves as interactive public amenities and learning experiences. The Master and Community Development Plans support the development of a mixed-use district with block, street, open spaces, parcel, and density patterns and designs that create a walkable, health-oriented, connected, multi-modal urban place. The approaches to and outcomes of this scope of work shall be guided by and support that goal.

WSP shall provide on-call services to the City for pre-development through development activities. Work shall be phased in alignment with private and City development plans at the Site.

WSP shall report to the Director of the Office of Metropolitan Redevelopment Agency (“MRA”), Director of Public Works, in the Public Works Department (“PWD”) or designee. All work performed must be approved in advance by the Director of Public Works, MRA Director or designee. Requests for assistance relating to Infrastructure made directly by Director of the Department of Community and Economic Development, the Office of Economic Development, and/or the MRA should be referred to the Director of Public Works for approval prior to any work being done to ensure availability of funds.

WSP made the following assumptions in making its offer that limit the scope of its work in this contract:

- WSP shall not provide design services
- The engineer of record (EOR) shall be responsible for performing QC/QA on all deliverables prior to review by WSP.

PHASE 1

Phase 1 is substantially complete and consists of the following tasks. Work on Phase 1 was commenced under a purchase order and will be completed pursuant to this Agreement.

TASK 1.1 – INITIAL PROJECT ESTABLISHMENT

WSP shall support development of preliminary and general Project Infrastructure development as follows:

- Prepare an initial Critical Path Schedule for Infrastructure and Disposition and Development Agreement (“DDA”) support.
- Organize a regular meeting schedule and process focused specifically on Project Infrastructure.

TASK 1.2 – INFRASTRUCTURE PREDEVELOPMENT, ENGINEERING, AND TECHNICAL REVIEW SERVICES

WSP shall identify the immediate needs to organize the predevelopment and engineering for Infrastructure.

- Assist MRA Director, PWD Director or designee in writing or reviewing the initial infrastructure scope(s) and/or RFPs which are for or include Infrastructure development.
- Assist in the review and selection of the predevelopment, engineering and design team(s) relating to Infrastructure. Note: the firm Opticos is the master plan consultant to the Office of Economic Development. Coordination with Opticos may be required.

TASK 1.3 – FILM STUDIO PRODUCTION LOT DEVELOPER NEGOTIATIONS SUPPORT

WSP shall provide Infrastructure predevelopment and engineering support to the PWD, MRA, and the City's chosen developer(s) in predevelopment and finalizing terms pertaining to Infrastructure and public improvements in a Disposition and Development Agreement for the redevelopment and expansion of the Midtown Studio Production Lot.

PHASE 2 OVERALL AND ONGOING SCOPE OF WORK

TASK 2.1 – PROJECT ESTABLISHMENT

WSP shall provide feedback to MRA Director, PWD Director or designee upon request relating to Infrastructure engineering and project management during predevelopment and development .

1. WSP shall provide input to prepare and/or feedback on Infrastructure components of drafts of Project Management Plans, Critical Path Schedules, and other key activities of the Project upon request by PWD or the MRA.
2. Continue development of the Critical Path Schedule

WSP shall refine the initial Critical Path Schedule for Infrastructure in coordination with the MRA to ensure coordination of the Project development process. WSP shall prepare and submit:

Initial schedule to focus on the first two (2) years;

- Phasing plan for Infrastructure in anticipation of MRA's redevelopment schedule and disposition of parcels, as well as Project readiness in alignment with the funding plan and PMP
 - Milestones for developers, the City and other entities related to Infrastructure
3. Development of a Risk Management Plan for Infrastructure engineering
 - Identify potential schedule risks relating to Infrastructure development.
 - Create a risk register relating to Infrastructure development.

4. Work in coordination with the MRA to prioritize risks and identify mitigation and allocation strategies to manage schedule and other Project risks with emphasis on addressing the Critical Path Schedule and appropriate risk allocation to promote implementation
5. WSP shall assist the MRA in preparing a Funding Plan for Project Infrastructure based on the preliminary time-based financial plan for the needs analysis By providing:
 - Expected costs for infrastructure and developer incentives, including timing for the outlay of those costs;
 - Available funding and financing sources including grants (state legislative grants, federal grants, NMDOT grants, environment department grants); value capture mechanisms (TID, PID); bond revenue; private and public financing.
 - Timelines for when the funding/financing will be needed.

TASK 2.2 – PROJECT IMPLEMENTATION

Provide expertise to support the implementation of the Project once the initial Project is established, as follows:

1. Assessment of Public Infrastructure Improvements and Plans
 - Upon request of the MRA or Director of Public Works, WSP shall provide the following services:
 - Drafting or reviewing and advising on scope(s) of work for technical and engineering team developing and/or impacting Infrastructure;
 - Reviewing and advising on RFP responses and selection of most qualified technical team(s);
 - Reviewing and advising on predevelopment and design work, scope, budget, invoicing, and schedule;
 - Advising on phasing of predevelopment, design and construction schedules and solicitation process relating to infrastructure;
 - Advising regarding RFP responses and selection of construction teams;
 - Advise on construction, scope, budget, invoicing, and schedule; and
 - Reviewing and advising on change orders, requests for clarifications, and other administrative issues typically arising in the bid, construction, and close-out phases of construction.
2. Assessment of Development Proposals and Plans for Infrastructure

- Upon request by the MRA or Director of Public Works, WSP shall:
 - Review and advise on Developer pro formas and other financial information for Infrastructure to assess the financial viability and responsiveness of the proposal;
 - Review and advise on concept plans and other designs to assess the engineering and design feasibility and responsiveness of the proposal with respect to Infrastructure;
 - Assist in preparing requests for additional information directed to bidders or offerors;
 - Assist with drafting responses to developer due diligence requests, such as requests to access the property
 - Participate in pre-submission meetings for RFPs related to development.
3. Coordination with Third Party Stakeholders when requested by the Director of Public Works or MRA:
- Engage adjacent property owners, utilities, and other third parties to assess potential impacts and risks to Project implementation.
 - Develop and negotiate agreements with such third parties.

TASK 2.4 – INFRASTRUCTURE ENGINEERING/TECHNICAL REVIEW SERVICES

WSP shall provide technical review services in collaboration with the PWD related to Infrastructure at the Site. This contract does not include WSP acting as the Engineer of Record (EOR) for the project. Upon request by the Director of Public Works or MRA, WSP shall help to write or review the initial infrastructure scope(s) of work, review and select the most qualified firms, and review the deliverables developed by the EOR and provide comments and recommendations.

Technical reviews and services shall include but not be limited to:

- Review of Plans and Plats
- Design Analysis Reports (DARs)
- Drainage Reports
- Design Plans at all phases
- Conformance to standards and specifications
- Construction Contract Book, including but not limited to special provisions, Notices to Contractors, and/or other supplemental contract documents
- A/E Contract Exhibit Review

- Safety Studies
- Traffic Impact Analysis
- Lighting and Signalization Reports
- Engineering Estimates Opinions of Probable Cost
- Value Engineering

Reviews shall be conducted utilizing Bluebeam software to track comments, verify changes and document design decisions. The EOR shall be responsible for providing QC/QA on all deliverables prior to submittal to the City and review by WSP.

- Meetings and Field Visits: WSP attend project development and review meetings in person or virtual depending on project needs.
- Deliverable Items: Technical review of design plans, studies, and other relevant data provided by engineering consultant at each design milestone (Bluebeam markup)
- Schedule: Dependent on project timeline determined by project needs and phasing.

TASK 2.5 – STAKEHOLDER MEETINGS

1. Internal Stakeholder Meetings

WSP shall attend meetings of the City’s Midtown Leadership Team to participate in and contribute to the advancement of the Midtown Project as directed by PWD. WSP shall also attend Infrastructure Team meetings as directed by the Director of Public Works. WSP will also support presentations to the Governing Body and Council Committees.

2. External Key Stakeholder Meetings

Upon request by the MRA Director, WSP shall support briefing external stakeholders such as developers, community groups, state regulators, at regular intervals on the progress of the Project.

TASK 2.6 – ONGOING PROJECT SUPPORT

WSP shall provide:

1. Schedule and document management, funding plans, reporting, communications, and phasing of public infrastructure and its intersection with private development
2. Representation of the City for purposes of Project Infrastructure as described in this Agreement.
3. Coordination with other City consultants working on Project as directed by the Director

of Public Works.

TASK 2.7 – TASK ADMINISTRATION

WSP shall:

1. Submit monthly invoices and monthly reports.
2. Attend project meetings and stay The purpose of the Owner’s Representative services described in this scope of work is to assist and represent the City of Santa Fe to establish and oversee an ongoing programmatic approach to implement the Infrastructure of the Midtown Master Plan and Community Development Plan (“Project”).

The redevelopment of the Santa Fe Midtown Site (“Site”) includes a goal of advancing sustainable, resilient, and regenerative development, while creating green infrastructure that serves as interactive public amenities and learning experiences. The Master and Community Development Plans support the development of a mixed-use district with block, street, open spaces, parcel, and density patterns and designs that create a walkable, health-oriented, connected, multi-modal urban place. The approaches to and outcomes of this scope of work shall be guided by and support that goal.

WSP shall provide on-call services to the City for pre-development through development activities. Work shall be phased in alignment with private and City development plans at the Site.

WSP shall report to the Director of the Office of Metropolitan Redevelopment Agency (“MRA”), Director of Public Works, in the Public Works Department (“PWD”) or designee. All work performed must be approved in advance by the Director of Public Works, MRA Director or designee . Requests for assistance relating to Infrastructure made directly by Director of the Department of Community and Economic Development, the Office of Economic Development, and/or the MRA should be referred to the Director of Public Works for approval prior to any work being done to ensure availability of funds.

WSP made the following assumptions in making its offer that limit the scope of its work in this contract:

- WSP shall not provide design services.
- The engineer of record (EOR) shall be responsible for performing QC/QA on all deliverables prior to review by WSP.

PHASE 1

Phase 1 is substantially complete and consists of the following tasks. Work on Phase 1 was commenced under a purchase order and will be completed pursuant to this Agreement.

TASK 1.1 – INITIAL PROJECT ESTABLISHMENT

WSP shall support development of preliminary and general Project Infrastructure development as follows:

- Prepare an initial Critical Path Schedule for Infrastructure and Disposition and Development Agreement (“DDA”) support.
- Organize a regular meeting schedule and process focused specifically on Project Infrastructure.

TASK 1.2 – INFRASTRUCTURE PREDEVELOPMENT, ENGINEERING, AND TECHNICAL REVIEW SERVICES

WSP shall identify the immediate needs to organize the predevelopment and engineering for Infrastructure.

- Assist MRA Director, PWD Director or designee in writing or reviewing the initial infrastructure scope(s) and/or RFPs which are for or include Infrastructure development.
- Assist in the review and selection of the predevelopment, engineering and design team(s) relating to Infrastructure. Note: the firm Opticos is the master plan consultant to the Office of Economic Development. Coordination with Opticos may be required.

TASK 1.3 – FILM STUDIO PRODUCTION LOT DEVELOPER NEGOTIATIONS SUPPORT

WSP shall provide Infrastructure predevelopment and engineering support to the PWD, MRA, and the City’s chosen developer(s) in predevelopment and finalizing terms pertaining to Infrastructure and public improvements in a Disposition and Development Agreement for the redevelopment and expansion of the Midtown Studio Production Lot.

PHASE 2 OVERALL AND ONGOING SCOPE OF WORK

TASK 2.1 – PROJECT ESTABLISHMENT

WSP shall provide feedback to MRA Director, PWD Director or designee upon request relating to Infrastructure engineering and project management during predevelopment and development .

1. WSP shall provide input to prepare and/or feedback on Infrastructure components of drafts of Project Management Plans, Critical Path Schedules, and other key activities of the Project upon request by PWD or the MRA.
2. Continue development of the Critical Path Schedule

WSP shall refine the initial Critical Path Schedule for Infrastructure in coordination with the MRA to ensure coordination of the Project development process. WSP shall prepare and submit:

Initial schedule to focus on the first two (2) years;

- Phasing plan for Infrastructure in anticipation of MRA’s redevelopment schedule and disposition of parcels, as well as Project readiness in alignment with the funding plan and PMP.
 - Milestones for developers, the City and other entities related to Infrastructure.
3. Development of a Risk Management Plan for Infrastructure engineering
 - Identify potential schedule risks relating to Infrastructure development.
 - Create a risk register relating to Infrastructure development.
 4. Work in coordination with the MRA to prioritize risks and identify mitigation and allocation strategies to manage schedule and other Project risks with emphasis on addressing the Critical Path Schedule and appropriate risk allocation to promote implementation.
 5. WSP shall assist the MRA in preparing a Funding Plan for Project Infrastructure based on the preliminary time-based financial plan for the needs analysis By providing:
 - Expected costs for infrastructure and developer incentives, including timing for the outlay of those costs;
 - Available funding and financing sources including grants (state legislative grants, federal grants, NMDOT grants, environment department grants); value capture mechanisms (TID, PID); bond revenue; private and public financing.
 - Timelines for when the funding/financing will be needed.

TASK 2.2 – PROJECT IMPLEMENTATION

Provide expertise to support the implementation of the Project once the initial Project is established, as follows:

1. Assessment of Public Infrastructure Improvements and Plans
 - Upon request of the MRA or Director of Public Works, WSP shall provide the following services:
 - Drafting or reviewing and advising on scope(s) of work for technical and engineering team developing and/or impacting Infrastructure;
 - Reviewing and advising on RFP responses and selection of most qualified technical team(s);
 - Reviewing and advising on predevelopment and design work, scope, budget, invoicing, and schedule;

- Advising on phasing of predevelopment, design and construction schedules and solicitation process relating to infrastructure;
- Advising regarding RFP responses and selection of construction teams;
- Advise on construction, scope, budget, invoicing, and schedule; and
- Reviewing and advising on change orders, requests for clarifications, and other administrative issues typically arising in the bid, construction, and close-out phases of construction.

2. Assessment of Development Proposals and Plans for Infrastructure

- Upon request by the MRA or Director of Public Works, WSP shall:
- Review and advise on Developer pro formas and other financial information for Infrastructure to assess the financial viability and responsiveness of the proposal.
- Review and advise on concept plans and other designs to assess the engineering and design feasibility and responsiveness of the proposal with respect to Infrastructure.
- Assist in preparing requests for additional information directed to bidders or offerors.
- Assist with drafting responses to developer due diligence requests, such as requests to access the property.
- Participate in pre-submission meetings for RFPs related to development.

3. Coordination with Third Party Stakeholders when requested by the Director of Public Works or MRA:

- Engage adjacent property owners, utilities, and other third parties to assess potential impacts and risks to Project implementation.
- Develop and negotiate agreements with such third parties.

TASK 2.4 – INFRASTRUCTURE ENGINEERING/TECHNICAL REVIEW SERVICES

WSP shall provide technical review services in collaboration with the PWD related to Infrastructure at the Site. This contract does not include WSP acting as the Engineer of Record (EOR) for the project. Upon request by the Director of Public Works or MRA, WSP shall help to write or review the initial infrastructure scope(s) of work, review and select the most qualified firms, and review the deliverables developed by the EOR and provide comments and recommendations.

Technical reviews and services shall include but not be limited to:

- Review of Plans and Plats
- Design Analysis Reports (DARs)
- Drainage Reports
- Design Plans at all phases
- Conformance to standards and specifications
- Construction Contract Book, including but not limited to special provisions, Notices to Contractors, and/or other supplemental contract documents
- A/E Contract Exhibit Review
- Safety Studies
- Traffic Impact Analysis
- Lighting and Signalization Reports
- Engineering Estimates Opinions of Probable Cost
- Value Engineering

Reviews shall be conducted utilizing Bluebeam software to track comments, verify changes and document design decisions. The EOR shall be responsible for providing QC/QA on all deliverables prior to submittal to the City and review by WSP.

- Meetings and Field Visits: WSP attend project development and review meetings in person or virtual depending on project needs.
- Deliverable Items: Technical review of design plans, studies, and other relevant data provided by engineering consultant at each design milestone (Bluebeam markup)
- Schedule: Dependent on project timeline determined by project needs and phasing.

TASK 2.5 – STAKEHOLDER MEETINGS

1. Internal Stakeholder Meetings

WSP shall attend meetings of the City’s Midtown Leadership Team to participate in and contribute to the advancement of the Midtown Project as directed by PWD. WSP shall also attend Infrastructure Team meetings as directed by the Director of Public Works. WSP will also support presentations to the Governing Body and Council Committees.

2. External Key Stakeholder Meetings

Upon request by the MRA Director, WSP shall support briefing external stakeholders such as developers, community groups, state regulators, at regular intervals on the progress of the Project.

TASK 2.6 – ONGOING PROJECT SUPPORT

WSP shall provide:

1. Schedule and document management, funding plans, reporting, communications, and phasing of public infrastructure and its intersection with private development.
2. Representation of the City for purposes of Project Infrastructure as described in this Agreement.
3. Coordination with other City consultants working on Project as directed by the Director of Public Works.

TASK 2.7 – TASK ADMINISTRATION

WSP shall:

1. Submit monthly invoices and monthly report.
2. Attend project meetings and stay in communication with the City’s Midtown Leadership Team.
3. Maintenance of project site and document management
 - All pertinent project records shall be tracked and stored in good order, all documents and presentations shall be professional, all invoices shall include a progress report and be timely.
 - Ensure that all work products and supporting documents are maintained in a repository readily accessible to all team members.

All documents and work products are the property of the City of Santa Fe and will be provided to the MRA Director by WSP upon termination of this agreement.in communication with the City’s Midtown Leadership Team.

3. Maintenance of project site and document management
 - All pertinent project records shall be tracked and stored in good order, all documents and presentations shall be professional, all invoices shall include a progress report and be timely.
 - Ensure that all work products and supporting documents are maintained in a repository readily accessible to all team members.

All documents and work products are the property of the City of Santa Fe and will be provided to the MRA Director by WSP upon termination of this agreement.

3. Standard of Performance; Licenses

A. The Contractor does hereby accept its designation as a professional service, rendering services related to Owner's Representation and Project Management Services for the City, as set forth in this Agreement. The Contractor represents that Contractor possesses the personnel, experience, and knowledge necessary to perform the services described under this Contract.

B. The Contractor agrees to obtain and maintain throughout the term of this Contract, all applicable professional and business licenses required by law, for itself, its employees, agents, representatives, and subcontractors.

4. Compensation

A. The City shall pay to the Contractor in full payment for services satisfactorily performed based upon milestones, such compensation not to exceed Ninety-thousand dollars, including gross receipts tax. The New Mexico gross receipts tax levied on the amounts payable under this Contract totaling Seven thousand Three-hundred Sixty-eight dollars and seventy-five cents (\$7,368.75) shall be paid by the City to the Contractor. **The total amount payable to the Contractor under this Agreement, including gross receipts tax and expenses, shall not exceed Ninety-thousand dollars (\$90,000). This amount is a maximum and not a guarantee that the work assigned to be performed by Contractor under this Contract shall equal the amount stated herein. The parties do not intend for the Contractor to continue to provide services without compensation when the total compensation amount is reached. Contractor is responsible for notifying the City when the services provided under this Contract reach the total compensation amount. In no event will the Contractor be paid for services provided in excess of the total compensation amount without this Contract being amended in writing prior to those services in excess of the total compensation amount being provided.**

B. Payment is subject to availability of funds pursuant to the Appropriations Paragraph set forth below and to any negotiations between the parties from year to year pursuant to Paragraph 1, Scope of Work, and to approval by the City. All invoices **MUST BE** received by the City no later than thirty (30) days after the termination of the Fiscal Year in which the services were delivered. Invoices received after such date **WILL NOT BE PAID.**

C. Payment in future fiscal years is subject to availability of funds pursuant to the Appropriations Paragraph set forth below and to any negotiations between the parties from year to year pursuant to Paragraph 1, Scope of Work, and to approval by the City. All invoices **MUST BE** received by the City no later than fifteen (15) days after the termination of the Fiscal Year in which the services were delivered. Invoices received after such date **WILL NOT BE PAID.**)

D. Contractor must submit a detailed statement accounting for all services performed and expenses incurred. If the City finds that the services are not acceptable, within thirty days after the date of receipt of written notice from the Contractor that payment is requested, it shall provide the Contractor a letter of exception explaining the defect or objection to the services, and outlining steps the Contractor may take to provide remedial action. Upon certification by the City that the services have been received and

accepted, payment shall be tendered to the Contractor within thirty days after the date of acceptance. If payment is made by mail, the payment shall be deemed tendered on the date it is postmarked. However, the City shall not incur late charges, interest, or penalties for failure to make payment within the time specified herein.

5. Term

THIS CONTRACT SHALL NOT BECOME EFFECTIVE UNTIL APPROVED BY THE CITY. This Contract shall terminate **December 31, 2027**, unless terminated pursuant to paragraph 4 (Termination), or paragraph 5 (Appropriations). The City reserves the right to renew this contract on an annual basis by mutual agreement not to exceed a total of four (4) years in accordance with NMSA 1978, Sections 13-1-150 through 152.

6. Termination

A. Grounds. The City may terminate this Agreement for convenience or cause. For contracts within their authority, the City Manager or their designee is authorized to provide the notice of termination, otherwise such notice of termination shall be provided by the Mayor, or their designee as authorized by the Governing Body. The Contractor may only terminate this Agreement based upon the City's uncured, material breach of this Agreement.

B. Notice; City Opportunity to Cure.

- 1) Except as otherwise provided in Paragraphs 7.A and 17, the City shall give Contractor written notice of termination at least thirty (30) days prior to the intended date of termination.
- 2) Contractor shall give City written notice of termination at least thirty (30) days prior to the intended date of termination, which notice shall (i) identify all the City's material breaches of this Agreement upon which the termination is based and (ii) state what the City must do to cure such material breaches. Contractor's notice of termination shall only be effective (i) if the City does not cure all material breaches within the thirty (30) day notice period or (ii) in the case of material breaches that cannot be cured within thirty (30) days, the City does not, within the thirty (30) day notice period, notify the Contractor of its intent to cure and begin with due diligence to cure the material breach.
- 3) Notwithstanding the foregoing, this Agreement may be terminated immediately upon written notice to the Contractor (i) if the Contractor becomes unable to perform the services contracted for, as determined by the City; (ii) if, during the term of this Agreement, the Contractor is suspended or debarred by the City; or (iii) the Agreement is terminated pursuant to Paragraph 6, "Appropriations", of this Agreement.

C. Liability. Except as otherwise expressly allowed or provided under this Agreement, the City's sole liability upon termination shall be to pay for acceptable work performed prior to the Contractor's receipt or issuance of a notice of termination; provided, however, that a notice of termination shall not nullify or otherwise affect either party's liability for pre-termination defaults under or breaches of this Agreement. The Contractor shall submit an invoice for such work within thirty (30) days of receiving or sending the notice of termination. THIS PROVISION IS NOT EXCLUSIVE AND DOES NOT WAIVE

THE CITY'S OTHER LEGAL RIGHTS AND REMEDIES CAUSED BY THE CONTRACTOR'S DEFAULT/BREACH OF THIS AGREEMENT.

7. Appropriations

The terms of this Contract are contingent upon sufficient appropriations and authorization being made by the City Council for the performance of this Contract. If sufficient appropriations and authorization are not made by the Governing Body, this Contract shall terminate immediately upon written notice being given by the City to the Contractor. The City's decision as to whether sufficient appropriations are available shall be accepted by the Contractor and shall be final. If the City proposes an amendment to the Contract to unilaterally reduce funding, the Contractor shall have the option to terminate the Contract or to agree to the reduced funding, within thirty (30) days of receipt of the proposed amendment.

8. Status of Contractor

The Contractor and its agents and employees are independent contractors performing construction services for the City and are not employees of the City. The Contractor and its agents and employees shall not accrue leave, retirement, insurance, bonding, use of City vehicles, or any other benefits afforded to employees of the City as a result of this Contract. The Contractor acknowledges that all sums received hereunder are reportable by the Contractor for tax purposes, including without limitation, self-employment and business income tax. The Contractor agrees not to purport to bind the City unless the Contractor has express written authority to do so, and then only within the strict limits of that authority.

9. Assignment

The Contractor shall not assign or transfer any interest in this Contract or assign any claims for money due or to become due under this Contract without the prior written approval of the City.

10. Subcontracting

The Contractor shall not subcontract any portion of the services to be performed under this Contract without the prior written approval of the City. No such subcontract shall relieve the primary Contractor from its obligations and liabilities under this Contract, nor shall any subcontract obligate direct payment from the City.

11. Release

Final payment of the amounts due under this Contract shall operate as a release of the City, its officers and employees from all payment liabilities, claims and obligations whatsoever arising from or under this Contract.

12. Confidentiality

Any confidential information provided to or developed by the Contractor in the performance of this Contract shall be kept confidential and shall not be made available to any individual or

organization by the Contractor without the prior written approval of the City.

13. Product of Service -- Copyright

All materials developed or acquired by the Contractor under this Contract shall become the property of the City and shall be delivered to the City no later than the termination date of this Contract. Nothing developed or produced, in whole or in part, by the Contractor under this Contract shall be the subject of an application for copyright or other claim of ownership by or on behalf of the Contractor.

14. Conflict of Interest; Governmental Conduct Act

A. The Contractor represents and warrants that it presently has no interest and, during the term of this Contract, shall not acquire any interest, direct or indirect, which would conflict in any manner or degree with the performance or services required under the Contract.

B. The Contractor further represents and warrants that it has complied with, and, during the term of this Contract, will continue to comply with, and that this Contract complies with all applicable provisions of the Governmental Conduct Act, Chapter 10, Article 16 NMSA 1978.

C. Contractor's representations and warranties in Paragraphs A and B of this Article 12 are material representations of fact upon which the City relied when this Contract was entered into by the parties. Contractor shall provide immediate written notice to the City if, at any time during the term of this Contract, Contractor learns that Contractor's representations and warranties in Paragraphs A and B of this Article 12 were erroneous on the effective date of this Contract or have become erroneous by reason of new or changed circumstances. If it is later determined that Contractor's representations and warranties in Paragraphs A and B of this Article 12 were erroneous on the effective date of this Contract or have become erroneous by reason of new or changed circumstances, in addition to other remedies available to the City and notwithstanding anything in the Contract to the contrary, the City may immediately terminate the Contract.

D. All terms defined in the Governmental Conduct Act have the same meaning in this section.

15. Amendment

A. This Agreement shall not be altered, changed, or amended except by instrument in writing executed by the parties hereto and all other required signatories.

B. If the City proposes an amendment to the Contract to unilaterally reduce funding due to budget or other considerations, the Contractor shall, within thirty (30) days of receipt of the proposed Amendment, have the option to terminate the Contract, pursuant to the termination provisions as set forth in Article 4 herein, or to agree to the reduced funding.

16. Entire Agreement.

This Agreement, together with any other documents incorporated herein by reference and all related Exhibits and Schedules constitutes the sole and entire agreement of the Parties with

respect to the subject matter of this Agreement, and supersedes all prior and contemporaneous understandings, agreements, representations, and warranties, both written and oral, with respect to the subject matter. In the event of any inconsistency between the statements in the body of this Agreement, and the related Exhibits and Schedules, the statements in the body of this Agreement shall control.

17. Merger

This Contract incorporates all the Agreements, covenants and understandings between the parties hereto concerning the subject matter hereof, and all such covenants, agreements, and understandings have been merged into this written contract.

Cooperative 13-1-135

This Contract is issued against the Cooperative Educational Services Master Agreement 2023-01-C211-ALL Design and Professional Services, Category 2 – Lot 1, Engineering and Consulting Services, established and maintained by Contractor, and through this language hereby incorporates this agreement by reference and is included in the order of precedence.

No prior Agreement or understanding, oral or otherwise, of the parties or their agents shall be valid or enforceable unless embodied in this Contract.

18. Penalties for violation of law

NMSA 1978, sections 13-1-28 through 13-1-199, imposes civil and criminal penalties for its violation. In addition, the New Mexico criminal statutes impose felony penalties for illegal bribes, gratuities, and kickbacks.

19. Equal Opportunity Compliance

The Contractor agrees to abide by all federal and state laws and rules and regulations, and Santa Fe City Code, pertaining to equal employment opportunity. In accordance with all such laws of the State of New Mexico, the Contractor assures that no person in the United States shall, on the grounds of race, religion, color, national origin, ancestry, sex, age, physical or mental handicap, or serious medical condition, spousal affiliation, sexual orientation or gender identity, be excluded from employment with or participation in, be denied the benefits of, or be otherwise subjected to discrimination under any program or activity performed under this Contract. If Contractor is found not to be in compliance with these requirements during the life of this Contract, Contractor agrees to take appropriate steps to correct these deficiencies.

20. Applicable Law

The laws of the State of New Mexico shall govern this Contract, without giving effect to its choice of law provisions. Venue shall be proper only in a New Mexico court of competent jurisdiction in accordance with NMSA 1978, section 38-3-2. By execution of this Contract, Contractor acknowledges and agrees to the jurisdiction of the courts of the State of New Mexico over any and all lawsuits arising under or out of any term of this Contract.

21. Workers Compensation

The Contractor agrees to comply with state laws and rules applicable to workers compensation benefits for its employees. If the Contractor fails to comply with the Workers Compensation Act and applicable rules when required to do so, this Contract may be terminated by the City.

22. Professional Liability Insurance

Contractor shall maintain professional liability insurance throughout the term of this Contract providing a minimum coverage in the amount required under the New Mexico Tort Claims Act. The Contractor shall furnish the City with proof of insurance of Contractor's compliance with the provisions of this section as a condition prior to performing services under this Contract.

23. Other Insurance

If the services contemplated under this Contract will be performed on or in City facilities or property, Contractor shall maintain in force during the entire term of this Contract, the following insurance coverage(s), naming the City as additional insured.

A. **Commercial General Liability** insurance shall be written on an occurrence basis and be as broad as ISO Form CG 00 01 with limits not less than \$2,000,000 per occurrence and \$2,000,000 in the aggregate for claims against bodily injury, personal and advertising injury, and property damage. Said policy shall include broad form Contractual Liability coverage and be endorsed to name the City of Santa Fe their officials, officers, employees, and agents as additional insureds.

B. **Broader Coverage and Limits.** The insurance requirements under this Contract shall be the greater of (1) the minimum coverage and limits specified in this Contract, or (2) the broader coverage and maximum limits of coverage of any insurance policy or proceeds available to the Named Insured. It is agreed that these insurance requirements shall not in any way act to reduce coverage that is broader or that includes higher limits than the minimums required herein. No representation is made that the minimum insurance requirements of this Contract are sufficient to cover the obligations of Contractor hereunder.

C. Contractor shall maintain the above insurance for the term of this Contract and name the City as an additional insured and provide for 30 days cancellation notice on any Certificate of Insurance form furnished by Contractor. Such certificate shall also specifically state the coverage provided under the policy is primary over any other valid and collectible insurance and provide a waiver of subrogation.

24. Records and Financial Audit

The Contractor shall maintain detailed time and expenditure records that indicate the date; time, nature and cost of services rendered during the Contract's term and effect and retain them for a period of three (3) years from the date of final payment under this Contract. The records shall be

subject to inspection by the City. The City shall have the right to audit billings both before and after payment. Payment under this Contract shall not foreclose the right of the City to recover excessive or illegal payments.

25. Indemnification

The Contractor shall indemnify and hold harmless the City from all actions, proceeding, claims, demands, costs, damages, attorneys' fees and all other liabilities and expenses of any kind from any source which may arise out of the performance of this Contract, caused by the negligent act or failure to act of the Contractor, its officers, employees, servants, subcontractors or agents, or if caused by the actions of any client of the Contractor resulting in injury or damage to persons or property during the time when the Contractor or any officer, agent, employee, servant or subcontractor thereof has or is performing services pursuant to this Contract. If any action, suit or proceeding related to the services performed by the Contractor or any officer, agent, employee, servant or subcontractor under this Contract is brought against the Contractor, the Contractor shall, as soon as practicable but no later than two (2) days after it receives notice thereof, notify the legal counsel of the City.

26. New Mexico Tort Claims Act

Any liability incurred by the City of Santa Fe in connection with this Contract is subject to the immunities and limitations of the New Mexico Tort Claims Act, Section 41-4-1, et. seq. NMSA 1978, as amended. The City and its "public employees" as defined in the New Mexico Tort Claims Act, do not waive sovereign immunity, do not waive any defense and do not waive any limitation of liability pursuant to law. No provision in this Contract modifies or waives any provision of the New Mexico Tort Claims Act.

27. Invalid Term or Condition

If any term or condition of this Contract shall be held invalid or unenforceable, the remainder of this Contract shall not be affected and shall be valid and enforceable.

28. Enforcement of Contract

A party's failure to require strict performance of any provision of this Contract shall not waive or diminish that party's right thereafter to demand strict compliance with that or any other provision. No waiver by a party of any of its rights under this Contract shall be effective unless express and in writing, and no effective waiver by a party of any of its rights shall be effective to waive any other rights.

29. Notices

Any notice required to be given to either party by this Contract shall be in writing and shall be delivered in person, by courier service or by U.S. mail, either first class or certified, return receipt requested, postage prepaid, as follows:

To the City:

Tim Farrell
Property Development Manager
City of Santa Fe Public Works
2651 Siringo Road, Building E
Santa Fe, NM 87504
tgfarrell@santafenm.gov
505-490-1659

To the Contractor:

Daniel Sims

Senior Vice President
WSP USA Inc
5411 Sky Center Drive, Building 650
Tampa, FL 33607
Dan.sims@wsp.com

30. Authority

If Contractor is other than a natural person, the individual(s) signing this Contract on behalf of Contractor represents and warrants that he or she has the power and authority to bind Contractor, and that no further action, resolution, or approval from Contractor is necessary to enter a binding contract.

31. Non-Collusion

In signing this Agreement, the Contractor certifies the Contractor has not, either directly or indirectly, entered into action in restraint of free competitive bidding in connection with this offer submitted to the City's Chief Procurement Officer.

32. Default/Breach

In case of Default and/or Breach by the Contractor, for any reason whatsoever, the City may procure the goods or services from another source and hold the Contractor responsible for any resulting excess costs and/or damages, including but not limited to, direct damages, indirect damages, consequential damages, special damages, and the City may also seek all other remedies under the terms of this Agreement and under law or equity.

33. Equitable Remedies

The Contractor acknowledges that its failure to comply with any provision of this Agreement will cause the City irrevocable harm and that a remedy at law for such a failure would be an inadequate remedy for the City, and the Contractor consents to the City's obtaining from a court of competent jurisdiction, specific performance, or injunction, or any other equitable relief in order to enforce such compliance. The City's rights to obtain equitable relief pursuant to this Agreement shall be in addition to, and not in lieu of, any other remedy that the City may have under applicable law, including, but not limited to, monetary damages.

34. Default and Force Majeure

The City reserves the right to cancel all, or any part of any orders placed under this Agreement without cost to the City, if the Contractor fails to meet the provisions of this Agreement and, except as otherwise provided herein, to hold the Contractor liable for any excess cost occasioned by the City due to the Contractor's default. The Contractor shall not be liable for any excess costs if failure to perform the order arises out of causes beyond the control and without the fault or negligence of the Contractor; such causes include, but are not restricted to, acts of God or the public enemy, acts of the State or Federal Government, fires, floods, epidemics, quarantine restrictions, strikes, freight embargoes, unusually severe weather and defaults of subcontractors due to any of the above, unless the City shall determine that the supplies or services to be furnished by the subcontractor were obtainable from other sources in sufficient time to permit the Contractor to meet the required delivery scheduled. The rights and remedies of the City provided in this Clause shall not be exclusive and are in addition to any other rights now being provided by law or under this Agreement.

[THIS SPACE INTENTIONALLY LEFT BLANK]

IN WITNESS WHEREOF, the Parties have executed this Contract as of the date of the signature by the required approval authorities below.

CITY OF SANTA FE:

John Blair
John Blair (Feb 20, 2024 14:19 MST)

JOHN BLAIR,
CITY MANAGER

DATE: Feb 20, 2024

CONTRACTOR

Daniel Sims

DANIEL SIMS,
SENIOR VICE PRESIDENT

DATE: 1/18/24

CRS#: 01195458002

Registration #: 230689

ATTEST:

Gerilyn Cardenas
Gerilyn Cardenas (Feb 21, 2024 09:31 MST)

GERALYN CARDENAS, INTERIM CITY CLERK
XIV

CITY ATTORNEY'S OFFICE:

Kevin L. Nault
Kevin L. Nault (Feb 1, 2024 14:32 MST)

ASSISTANT CITY ATTORNEY

APPROVED FOR FINANCES:

Emily K. Oster
Emily K. Oster (Feb 19, 2024 18:11 MST)

EMILY OSTER, FINANCE DIRECTOR

5250610/572960 AH
Org. Name/Org#: AH



City of Santa Fe
Treasury Department
200 Lincoln Ave.
Santa Fe, New Mexico 87504-0909
505-955-6551

BUSINESS REGISTRATION

Business Name: WSP USA INC.
DBA: WSP USA INC.

Business Location: 2440 LOUISIANA BLVD STE. 400
ALBUQUERQUE, NM 87110

Owner: Jodi Miller

License Number: 230689

Issued Date: August 16, 2023

Expiration Date: August 16, 2024

CRS Number: 01195458002

License Type: Business License - Renewable

Classification: Out of Jurisdiction Business License

Fees Paid: \$10.00

WSP USA INC.
4139 Oregon Pike Oregon Pike
EPHRATA, PA 17522

THIS IS NOT A CONSTRUCTION PERMIT OR SIGN PERMIT.
APPROPRIATE PERMITS MUST BE OBTAINED FROM THE CITY
OF SANTA FE BUILDING PERMIT DIVISION PRIOR TO
COMMENCEMENT OF ANY CONSTRUCTION OR THE
INSTALLATION OF ANY EXTERIOR SIGN.

THIS REGISTRATION/LICENSE IS NOT TRANSFERRABLE TO
OTHER BUSINESSES OR PREMISES.

TO BE POSTED IN A CONSPICUOUS PLACE



CERTIFICATE OF LIABILITY INSURANCE

DATE (MM/DD/YYYY)

11/8/2023

THIS CERTIFICATE IS ISSUED AS A MATTER OF INFORMATION ONLY AND CONFERS NO RIGHTS UPON THE CERTIFICATE HOLDER. THIS CERTIFICATE DOES NOT AFFIRMATIVELY OR NEGATIVELY AMEND, EXTEND OR ALTER THE COVERAGE AFFORDED BY THE POLICIES BELOW. THIS CERTIFICATE OF INSURANCE DOES NOT CONSTITUTE A CONTRACT BETWEEN THE ISSUING INSURER(S), AUTHORIZED REPRESENTATIVE OR PRODUCER, AND THE CERTIFICATE HOLDER.

IMPORTANT: If the certificate holder is an ADDITIONAL INSURED, the policy(ies) must have ADDITIONAL INSURED provisions or be endorsed. If SUBROGATION IS WAIVED, subject to the terms and conditions of the policy, certain policies may require an endorsement. A statement on this certificate does not confer rights to the certificate holder in lieu of such endorsement(s).

PRODUCER Arthur J. Gallagher Risk Management Services, LLC 300 Madison Avenue, 28th Floor New York NY 10017	CONTACT NAME: AJG Service Team	
	PHONE (A/C, No. Ext): 212-994-7020	FAX (A/C, No): 212-994-7074
E-MAIL ADDRESS: GGB.WSPUS.CertRequest@ajg.com		
INSURER(S) AFFORDING COVERAGE		NAIC #
INSURER A: QBE Specialty Insurance Company		11515
INSURER B:		
INSURER C:		
INSURER D:		
INSURER E:		
INSURER F:		

INSURED WSPGL08-01
 WSP USA Inc.
 One Penn Plaza
 New York, NY 10119

COVERAGES

CERTIFICATE NUMBER: 1318051649

REVISION NUMBER:

THIS IS TO CERTIFY THAT THE POLICIES OF INSURANCE LISTED BELOW HAVE BEEN ISSUED TO THE INSURED NAMED ABOVE FOR THE POLICY PERIOD INDICATED. NOTWITHSTANDING ANY REQUIREMENT, TERM OR CONDITION OF ANY CONTRACT OR OTHER DOCUMENT WITH RESPECT TO WHICH THIS CERTIFICATE MAY BE ISSUED OR MAY PERTAIN, THE INSURANCE AFFORDED BY THE POLICIES DESCRIBED HEREIN IS SUBJECT TO ALL THE TERMS, EXCLUSIONS AND CONDITIONS OF SUCH POLICIES. LIMITS SHOWN MAY HAVE BEEN REDUCED BY PAID CLAIMS.

INSR LTR	TYPE OF INSURANCE	ADDL INSD	SUBR WVD	POLICY NUMBER	POLICY EFF (MM/DD/YYYY)	POLICY EXP (MM/DD/YYYY)	LIMITS
	COMMERCIAL GENERAL LIABILITY <input type="checkbox"/> CLAIMS-MADE <input type="checkbox"/> OCCUR GEN'L AGGREGATE LIMIT APPLIES PER: <input type="checkbox"/> POLICY <input type="checkbox"/> PRO-JECT <input type="checkbox"/> LOC OTHER:						EACH OCCURRENCE \$ DAMAGE TO RENTED PREMISES (Ea occurrence) \$ MED EXP (Any one person) \$ PERSONAL & ADV INJURY \$ GENERAL AGGREGATE \$ PRODUCTS - COMP/OP AGG \$ \$
	AUTOMOBILE LIABILITY <input type="checkbox"/> ANY AUTO <input type="checkbox"/> OWNED AUTOS ONLY <input type="checkbox"/> SCHEDULED AUTOS <input type="checkbox"/> HIRED AUTOS ONLY <input type="checkbox"/> NON-OWNED AUTOS ONLY						COMBINED SINGLE LIMIT (Ea accident) \$ BODILY INJURY (Per person) \$ BODILY INJURY (Per accident) \$ PROPERTY DAMAGE (Per accident) \$ \$
	UMBRELLA LIAB <input type="checkbox"/> OCCUR EXCESS LIAB <input type="checkbox"/> CLAIMS-MADE DED RETENTION \$						EACH OCCURRENCE \$ AGGREGATE \$ \$
	WORKERS COMPENSATION AND EMPLOYERS' LIABILITY ANY PROPRIETOR/PARTNER/EXECUTIVE OFFICER/MEMBER EXCLUDED? <input type="checkbox"/> Y / N <input checked="" type="checkbox"/> N / A (Mandatory in NH) If yes, describe under DESCRIPTION OF OPERATIONS below						PER STATUTE OTH-ER E.L. EACH ACCIDENT \$ E.L. DISEASE - EA EMPLOYEE \$ E.L. DISEASE - POLICY LIMIT \$
A	Professional Liability CLAIMS-MADE			QPL0022630	11/1/2023	10/31/2024	Per Claim Aggregate \$2,000,000 \$2,000,000

DESCRIPTION OF OPERATIONS / LOCATIONS / VEHICLES (ACORD 101, Additional Remarks Schedule, may be attached if more space is required)

THIRTY (30) DAYS NOTICE OF CANCELLATION

RE: Project Number: 31000712.000. Project Description: Owner's Representative and Project Management Services for Midtown Redevelopment.

CERTIFICATE HOLDER**CANCELLATION**

City of Santa Fe
 PO Box 909
 Santa Fe NM 87504

SHOULD ANY OF THE ABOVE DESCRIBED POLICIES BE CANCELLED BEFORE THE EXPIRATION DATE THEREOF, NOTICE WILL BE DELIVERED IN ACCORDANCE WITH THE POLICY PROVISIONS.

AUTHORIZED REPRESENTATIVE

© 1988-2015 ACORD CORPORATION. All rights reserved.







24-0311 WSP USA, Inc.

Final Audit Report

2024-04-30

Created:	2024-04-30
By:	Xavier Vigil (xivigil@ci.santa-fe.nm.us)
Status:	Signed
Transaction ID:	CBJCHBCAABAAu_9xEH4UC-FZsOVAZ8CiWUQ7agFbJutR

"24-0311 WSP USA, Inc." History

-  Document created by Xavier Vigil (xivigil@ci.santa-fe.nm.us)
2024-04-30 - 5:45:48 PM GMT- IP address: 63.232.20.2
-  Document emailed to Alan Webber (amwebber@santafenm.gov) for signature
2024-04-30 - 5:47:46 PM GMT
-  Email viewed by Alan Webber (amwebber@santafenm.gov)
2024-04-30 - 6:03:48 PM GMT- IP address: 146.75.175.1
-  Document e-signed by Alan Webber (amwebber@santafenm.gov)
Signature Date: 2024-04-30 - 8:55:53 PM GMT - Time Source: server- IP address: 63.232.20.2
-  Document emailed to GERALYN CARDENAS (gfcardenas@santafenm.gov) for signature
2024-04-30 - 8:56:00 PM GMT
-  Email viewed by GERALYN CARDENAS (gfcardenas@santafenm.gov)
2024-04-30 - 10:00:29 PM GMT- IP address: 104.47.64.254
-  Document e-signed by GERALYN CARDENAS (gfcardenas@santafenm.gov)
Signature Date: 2024-04-30 - 10:00:41 PM GMT - Time Source: server- IP address: 63.232.20.2
-  Agreement completed.
2024-04-30 - 10:00:41 PM GMT



City of Santa Fe, New Mexico

Memorandum



DATE: February 15, 2024

TO: John Blair, City Manager *John Blair*
John Blair (Feb 20, 2024 14:19 MST)

VIA: Regina Wheeler, Public Works Department Director *Regina Wheeler*
Regina Wheeler (Feb 15, 2024 14:22:36PT)
Rich Brown, Community Development Director *Richard Brown*

FROM: Tim Farrell, Facilities Division, Property Development Manager *Timothy Farrell*

ACTION:

Request for the Approval of a Professional Services Contract in the Total Amount of \$150,000, Including GRT, with WSP USA, Inc. for Owner’s Representative Project Manager Services to Support Redevelopment at Midtown. (Tim Farrell, Facilities Division Property Development Manager, tgfarrell@santafenm.gov, 505-490-1659)

BACKGROUND AND SUMMARY:

Pursuant to Resolution #2022-12, the Midtown Master Plan was adopted by the Governing Body on November 30, 2022 (Resolution #2022-68), and the Midtown Community Development Plan was adopted on January 25, 2023 (Resolution #2023-5). Also pursuant to Resolution #2022-12, the City of Santa Fe released requests for proposals (RFPs) for the redevelopment of the Midtown Studios Production Lot, the Visual Arts Center, and Garson Theater in December 2022. An Early Negotiation Agreement (ENA) for the development of the Midtown Studios Production Lot was approved by the Governing Body on July 26, 2023.

To continue supporting the ENA process and early developments at Midtown beyond the previously approved \$60,000 Purchase order on 8/29/23, it is imperative the City continue to fund and advance the infrastructure planning and design. The Owner Representative/Project Manager role brings urban redevelopment expertise and experience to help manage the City’s Infrastructure project. The current phase includes the sitewide stormwater plan, complete streets, utilities, sidewalks, and other spine infrastructure. The Owner Representative Project Manager will begin to identify all the program elements and map out necessary infrastructure development actions in a critical path schedule to support successful redevelopment. They will also assist with parcellation and development negotiations as needed. WSP’s proposal demonstrates that the company has the capacity and expertise to perform this work.

Engineering and design services will be provided by separate firms via RFPs which are underway and CES as needed. The Owner Representative/Project Manager will help the City to ensure the successful planning and execution of the necessary scopes, processes, and deliverables for engineering and other services required for the Midtown redevelopment project.

Funding for the Owner Representative and Project Management Contract is from FY23 New Mexico Gross Receipts Tax earned in excess of budgeted revenues.

PROCUREMENT METHOD:

The procurement method is the Cooperative Educational Services Price Agreement (CES) CES Contract #'s 2023-01-C211-ALL which expires on October 5, 2026.

FUNDING SOURCE:

The funding source is NMGRT Prior Year Excess funds.

Project Name/Ledger ID: Midtown Improvements/MTC245250D-Design
Fund Name/Number: MIDTOWN CIP/525
Munis Org Name/Number: MTC CapPrj/5250610
Munis Object Name/Number: WIP Design/572960

ATTACHMENTS:

WSP Contract
WSP Proposal(s)
WSP Project Schedule
WSP Procurement Documents (CES)
WSP Certificate of Insurance
WSP Business License
Summary of Contracts
Procurement Checklist

Item #: 24-0112

Munis Contract #: ~~3204433~~
3204300

CES Contact#: 2023-01-C211-ALL

CITY OF SANTA FE

PROFESSIONAL SERVICES CONTRACT

THIS CONTRACT is made and entered into by and between the City of Santa Fe, New Mexico, hereinafter referred to as the “City,” and **WSP USA, Inc.**, hereinafter referred to as the “Contractor,” and is effective as of the date set forth below upon which it is executed by the Parties.

RECITALS

WHEREAS, the Chief Procurement Officer of the City has made the determination that this Agreement is in accordance with the provisions of the New Mexico Procurement Code (NMSA 1978, 13-1-28 et seq.) pursuant to NMSA 1978, section 13-1-135; and

WHEREAS, the Contractor is one of such requisite and qualifications and is willing to engage with the City for professional services, in accordance with the terms and conditions hereinafter set out, and the Contractor understanding and consenting to the foregoing is willing to render such professional services as outlined in the Agreement.

The City and the Contractor hereby agree as follows:

1. Definitions

Infrastructure: The services and facilities that support a built environment, including but not limited to: utilities including water, waste water/sewer, surface and stormwater management and drainage, electricity, natural gas, and telecommunications including Internet access; all components of public rights of way including roads, bicycle and pedestrian paths, sidewalks, trails, parking, lighting, traffic signals, and property entrances; parks, open spaces, civic spaces, and fixtures therein (e.g., child play structures, public seating).

Predevelopment: Phase of project between establishing the Master Plan and Development Plan and entering into development agreements and initiating design of infrastructure. Considers various aspects and risks and focuses on financing and identifying steps to prepare for development activities.

2. Scope of Work

The purpose of the Owner’s Representative services described in this scope of work is to assist

CoSF

Version 2 09.05.2023

and represent the City of Santa Fe to establish and oversee an ongoing programmatic approach to implement the Infrastructure of the Midtown Master Plan and Community Development Plan (“Project”).

The redevelopment of the Santa Fe Midtown Site (“Site”) includes a goal of advancing sustainable, resilient, and regenerative development, while creating green infrastructure that serves as interactive public amenities and learning experiences. The Master and Community Development Plans support the development of a mixed-use district with block, street, open spaces, parcel, and density patterns and designs that create a walkable, health-oriented, connected, multi-modal urban place. The approaches to and outcomes of this scope of work shall be guided by and support that goal.

WSP shall provide on-call services to the City for pre-development through development activities. Work shall be phased in alignment with private and City development plans at the Site.

WSP shall report to the Director of the Office of Metropolitan Redevelopment Agency (“MRA”), Director of Public Works, in the Public Works Department (“PWD”) or designee. All work performed must be approved in advance by the Director of Public Works, MRA Director or designee. Requests for assistance relating to Infrastructure made directly by Director of the Department of Community and Economic Development, the Office of Economic Development, and/or the MRA should be referred to the Director of Public Works for approval prior to any work being done to ensure availability of funds.

WSP made the following assumptions in making its offer that limit the scope of its work in this contract:

- WSP shall not provide design services
- The engineer of record (EOR) shall be responsible for performing QC/QA on all deliverables prior to review by WSP.

PHASE 1

Phase 1 is substantially complete and consists of the following tasks. Work on Phase 1 was commenced under a purchase order and will be completed pursuant to this Agreement.

TASK 1.1 – INITIAL PROJECT ESTABLISHMENT

WSP shall support development of preliminary and general Project Infrastructure development as follows:

- Prepare an initial Critical Path Schedule for Infrastructure and Disposition and Development Agreement (“DDA”) support.
- Organize a regular meeting schedule and process focused specifically on Project Infrastructure.

TASK 1.2 – INFRASTRUCTURE PREDEVELOPMENT, ENGINEERING, AND TECHNICAL REVIEW SERVICES

WSP shall identify the immediate needs to organize the predevelopment and engineering for Infrastructure.

- Assist MRA Director, PWD Director or designee in writing or reviewing the initial infrastructure scope(s) and/or RFPs which are for or include Infrastructure development.
- Assist in the review and selection of the predevelopment, engineering and design team(s) relating to Infrastructure. Note: the firm Opticos is the master plan consultant to the Office of Economic Development. Coordination with Opticos may be required.

TASK 1.3 – FILM STUDIO PRODUCTION LOT DEVELOPER NEGOTIATIONS SUPPORT

WSP shall provide Infrastructure predevelopment and engineering support to the PWD, MRA, and the City's chosen developer(s) in predevelopment and finalizing terms pertaining to Infrastructure and public improvements in a Disposition and Development Agreement for the redevelopment and expansion of the Midtown Studio Production Lot.

PHASE 2 OVERALL AND ONGOING SCOPE OF WORK

TASK 2.1 – PROJECT ESTABLISHMENT

WSP shall provide feedback to MRA Director, PWD Director or designee upon request relating to Infrastructure engineering and project management during predevelopment and development .

1. WSP shall provide input to prepare and/or feedback on Infrastructure components of drafts of Project Management Plans, Critical Path Schedules, and other key activities of the Project upon request by PWD or the MRA.
2. Continue development of the Critical Path Schedule

WSP shall refine the initial Critical Path Schedule for Infrastructure in coordination with the MRA to ensure coordination of the Project development process. WSP shall prepare and submit:

Initial schedule to focus on the first two (2) years;

- Phasing plan for Infrastructure in anticipation of MRA's redevelopment schedule and disposition of parcels, as well as Project readiness in alignment with the funding plan and PMP
 - Milestones for developers, the City and other entities related to Infrastructure
3. Development of a Risk Management Plan for Infrastructure engineering
 - Identify potential schedule risks relating to Infrastructure development.
 - Create a risk register relating to Infrastructure development.

4. Work in coordination with the MRA to prioritize risks and identify mitigation and allocation strategies to manage schedule and other Project risks with emphasis on addressing the Critical Path Schedule and appropriate risk allocation to promote implementation
5. WSP shall assist the MRA in preparing a Funding Plan for Project Infrastructure based on the preliminary time-based financial plan for the needs analysis By providing:
 - Expected costs for infrastructure and developer incentives, including timing for the outlay of those costs;
 - Available funding and financing sources including grants (state legislative grants, federal grants, NMDOT grants, environment department grants); value capture mechanisms (TID, PID); bond revenue; private and public financing.
 - Timelines for when the funding/financing will be needed.

TASK 2.2 – PROJECT IMPLEMENTATION

Provide expertise to support the implementation of the Project once the initial Project is established, as follows:

1. Assessment of Public Infrastructure Improvements and Plans
 - Upon request of the MRA or Director of Public Works, WSP shall provide the following services:
 - Drafting or reviewing and advising on scope(s) of work for technical and engineering team developing and/or impacting Infrastructure;
 - Reviewing and advising on RFP responses and selection of most qualified technical team(s);
 - Reviewing and advising on predevelopment and design work, scope, budget, invoicing, and schedule;
 - Advising on phasing of predevelopment, design and construction schedules and solicitation process relating to infrastructure;
 - Advising regarding RFP responses and selection of construction teams;
 - Advise on construction, scope, budget, invoicing, and schedule; and
 - Reviewing and advising on change orders, requests for clarifications, and other administrative issues typically arising in the bid, construction, and close-out phases of construction.
2. Assessment of Development Proposals and Plans for Infrastructure

- Upon request by the MRA or Director of Public Works, WSP shall:
 - Review and advise on Developer pro formas and other financial information for Infrastructure to assess the financial viability and responsiveness of the proposal;
 - Review and advise on concept plans and other designs to assess the engineering and design feasibility and responsiveness of the proposal with respect to Infrastructure;
 - Assist in preparing requests for additional information directed to bidders or offerors;
 - Assist with drafting responses to developer due diligence requests, such as requests to access the property
 - Participate in pre-submission meetings for RFPs related to development.
3. Coordination with Third Party Stakeholders when requested by the Director of Public Works or MRA:
- Engage adjacent property owners, utilities, and other third parties to assess potential impacts and risks to Project implementation.
 - Develop and negotiate agreements with such third parties.

TASK 2.4 – INFRASTRUCTURE ENGINEERING/TECHNICAL REVIEW SERVICES

WSP shall provide technical review services in collaboration with the PWD related to Infrastructure at the Site. This contract does not include WSP acting as the Engineer of Record (EOR) for the project. Upon request by the Director of Public Works or MRA, WSP shall help to write or review the initial infrastructure scope(s) of work, review and select the most qualified firms, and review the deliverables developed by the EOR and provide comments and recommendations.

Technical reviews and services shall include but not be limited to:

- Review of Plans and Plats
- Design Analysis Reports (DARs)
- Drainage Reports
- Design Plans at all phases
- Conformance to standards and specifications
- Construction Contract Book, including but not limited to special provisions, Notices to Contractors, and/or other supplemental contract documents
- A/E Contract Exhibit Review

- Safety Studies
- Traffic Impact Analysis
- Lighting and Signalization Reports
- Engineering Estimates Opinions of Probable Cost
- Value Engineering

Reviews shall be conducted utilizing Bluebeam software to track comments, verify changes and document design decisions. The EOR shall be responsible for providing QC/QA on all deliverables prior to submittal to the City and review by WSP.

- Meetings and Field Visits: WSP attend project development and review meetings in person or virtual depending on project needs.
- Deliverable Items: Technical review of design plans, studies, and other relevant data provided by engineering consultant at each design milestone (Bluebeam markup)
- Schedule: Dependent on project timeline determined by project needs and phasing.

TASK 2.5 – STAKEHOLDER MEETINGS

1. Internal Stakeholder Meetings

WSP shall attend meetings of the City’s Midtown Leadership Team to participate in and contribute to the advancement of the Midtown Project as directed by PWD. WSP shall also attend Infrastructure Team meetings as directed by the Director of Public Works. WSP will also support presentations to the Governing Body and Council Committees.

2. External Key Stakeholder Meetings

Upon request by the MRA Director, WSP shall support briefing external stakeholders such as developers, community groups, state regulators, at regular intervals on the progress of the Project.

TASK 2.6 – ONGOING PROJECT SUPPORT

WSP shall provide:

1. Schedule and document management, funding plans, reporting, communications, and phasing of public infrastructure and its intersection with private development
2. Representation of the City for purposes of Project Infrastructure as described in this Agreement.
3. Coordination with other City consultants working on Project as directed by the Director

of Public Works.

TASK 2.7 – TASK ADMINISTRATION

WSP shall:

1. Submit monthly invoices and monthly reports.
2. Attend project meetings and stay The purpose of the Owner’s Representative services described in this scope of work is to assist and represent the City of Santa Fe to establish and oversee an ongoing programmatic approach to implement the Infrastructure of the Midtown Master Plan and Community Development Plan (“Project”).

The redevelopment of the Santa Fe Midtown Site (“Site”) includes a goal of advancing sustainable, resilient, and regenerative development, while creating green infrastructure that serves as interactive public amenities and learning experiences. The Master and Community Development Plans support the development of a mixed-use district with block, street, open spaces, parcel, and density patterns and designs that create a walkable, health-oriented, connected, multi-modal urban place. The approaches to and outcomes of this scope of work shall be guided by and support that goal.

WSP shall provide on-call services to the City for pre-development through development activities. Work shall be phased in alignment with private and City development plans at the Site.

WSP shall report to the Director of the Office of Metropolitan Redevelopment Agency (“MRA”), Director of Public Works, in the Public Works Department (“PWD”) or designee. All work performed must be approved in advance by the Director of Public Works, MRA Director or designee . Requests for assistance relating to Infrastructure made directly by Director of the Department of Community and Economic Development, the Office of Economic Development, and/or the MRA should be referred to the Director of Public Works for approval prior to any work being done to ensure availability of funds.

WSP made the following assumptions in making its offer that limit the scope of its work in this contract:

- WSP shall not provide design services.
- The engineer of record (EOR) shall be responsible for performing QC/QA on all deliverables prior to review by WSP.

PHASE 1

Phase 1 is substantially complete and consists of the following tasks. Work on Phase 1 was commenced under a purchase order and will be completed pursuant to this Agreement.

TASK 1.1 – INITIAL PROJECT ESTABLISHMENT

WSP shall support development of preliminary and general Project Infrastructure development as follows:

- Prepare an initial Critical Path Schedule for Infrastructure and Disposition and Development Agreement (“DDA”) support.
- Organize a regular meeting schedule and process focused specifically on Project Infrastructure.

TASK 1.2 – INFRASTRUCTURE PREDEVELOPMENT, ENGINEERING, AND TECHNICAL REVIEW SERVICES

WSP shall identify the immediate needs to organize the predevelopment and engineering for Infrastructure.

- Assist MRA Director, PWD Director or designee in writing or reviewing the initial infrastructure scope(s) and/or RFPs which are for or include Infrastructure development.
- Assist in the review and selection of the predevelopment, engineering and design team(s) relating to Infrastructure. Note: the firm Opticos is the master plan consultant to the Office of Economic Development. Coordination with Opticos may be required.

TASK 1.3 – FILM STUDIO PRODUCTION LOT DEVELOPER NEGOTIATIONS SUPPORT

WSP shall provide Infrastructure predevelopment and engineering support to the PWD, MRA, and the City’s chosen developer(s) in predevelopment and finalizing terms pertaining to Infrastructure and public improvements in a Disposition and Development Agreement for the redevelopment and expansion of the Midtown Studio Production Lot.

PHASE 2 OVERALL AND ONGOING SCOPE OF WORK

TASK 2.1 – PROJECT ESTABLISHMENT

WSP shall provide feedback to MRA Director, PWD Director or designee upon request relating to Infrastructure engineering and project management during predevelopment and development .

1. WSP shall provide input to prepare and/or feedback on Infrastructure components of drafts of Project Management Plans, Critical Path Schedules, and other key activities of the Project upon request by PWD or the MRA.
2. Continue development of the Critical Path Schedule

WSP shall refine the initial Critical Path Schedule for Infrastructure in coordination with the MRA to ensure coordination of the Project development process. WSP shall prepare and submit:

Initial schedule to focus on the first two (2) years;

- Phasing plan for Infrastructure in anticipation of MRA’s redevelopment schedule and disposition of parcels, as well as Project readiness in alignment with the funding plan and PMP.
 - Milestones for developers, the City and other entities related to Infrastructure.
3. Development of a Risk Management Plan for Infrastructure engineering
 - Identify potential schedule risks relating to Infrastructure development.
 - Create a risk register relating to Infrastructure development.
 4. Work in coordination with the MRA to prioritize risks and identify mitigation and allocation strategies to manage schedule and other Project risks with emphasis on addressing the Critical Path Schedule and appropriate risk allocation to promote implementation.
 5. WSP shall assist the MRA in preparing a Funding Plan for Project Infrastructure based on the preliminary time-based financial plan for the needs analysis By providing:
 - Expected costs for infrastructure and developer incentives, including timing for the outlay of those costs;
 - Available funding and financing sources including grants (state legislative grants, federal grants, NMDOT grants, environment department grants); value capture mechanisms (TID, PID); bond revenue; private and public financing.
 - Timelines for when the funding/financing will be needed.

TASK 2.2 – PROJECT IMPLEMENTATION

Provide expertise to support the implementation of the Project once the initial Project is established, as follows:

1. Assessment of Public Infrastructure Improvements and Plans
 - Upon request of the MRA or Director of Public Works, WSP shall provide the following services:
 - Drafting or reviewing and advising on scope(s) of work for technical and engineering team developing and/or impacting Infrastructure;
 - Reviewing and advising on RFP responses and selection of most qualified technical team(s);
 - Reviewing and advising on predevelopment and design work, scope, budget, invoicing, and schedule;

- Advising on phasing of predevelopment, design and construction schedules and solicitation process relating to infrastructure;
- Advising regarding RFP responses and selection of construction teams;
- Advise on construction, scope, budget, invoicing, and schedule; and
- Reviewing and advising on change orders, requests for clarifications, and other administrative issues typically arising in the bid, construction, and close-out phases of construction.

2. Assessment of Development Proposals and Plans for Infrastructure

- Upon request by the MRA or Director of Public Works, WSP shall:
- Review and advise on Developer pro formas and other financial information for Infrastructure to assess the financial viability and responsiveness of the proposal.
- Review and advise on concept plans and other designs to assess the engineering and design feasibility and responsiveness of the proposal with respect to Infrastructure.
- Assist in preparing requests for additional information directed to bidders or offerors.
- Assist with drafting responses to developer due diligence requests, such as requests to access the property.
- Participate in pre-submission meetings for RFPs related to development.

3. Coordination with Third Party Stakeholders when requested by the Director of Public Works or MRA:

- Engage adjacent property owners, utilities, and other third parties to assess potential impacts and risks to Project implementation.
- Develop and negotiate agreements with such third parties.

TASK 2.4 – INFRASTRUCTURE ENGINEERING/TECHNICAL REVIEW SERVICES

WSP shall provide technical review services in collaboration with the PWD related to Infrastructure at the Site. This contract does not include WSP acting as the Engineer of Record (EOR) for the project. Upon request by the Director of Public Works or MRA, WSP shall help to write or review the initial infrastructure scope(s) of work, review and select the most qualified firms, and review the deliverables developed by the EOR and provide comments and recommendations.

Technical reviews and services shall include but not be limited to:

- Review of Plans and Plats
- Design Analysis Reports (DARs)
- Drainage Reports
- Design Plans at all phases
- Conformance to standards and specifications
- Construction Contract Book, including but not limited to special provisions, Notices to Contractors, and/or other supplemental contract documents
- A/E Contract Exhibit Review
- Safety Studies
- Traffic Impact Analysis
- Lighting and Signalization Reports
- Engineering Estimates Opinions of Probable Cost
- Value Engineering

Reviews shall be conducted utilizing Bluebeam software to track comments, verify changes and document design decisions. The EOR shall be responsible for providing QC/QA on all deliverables prior to submittal to the City and review by WSP.

- Meetings and Field Visits: WSP attend project development and review meetings in person or virtual depending on project needs.
- Deliverable Items: Technical review of design plans, studies, and other relevant data provided by engineering consultant at each design milestone (Bluebeam markup)
- Schedule: Dependent on project timeline determined by project needs and phasing.

TASK 2.5 – STAKEHOLDER MEETINGS

1. Internal Stakeholder Meetings

WSP shall attend meetings of the City’s Midtown Leadership Team to participate in and contribute to the advancement of the Midtown Project as directed by PWD. WSP shall also attend Infrastructure Team meetings as directed by the Director of Public Works. WSP will also support presentations to the Governing Body and Council Committees.

2. External Key Stakeholder Meetings

Upon request by the MRA Director, WSP shall support briefing external stakeholders such as developers, community groups, state regulators, at regular intervals on the progress of the Project.

TASK 2.6 – ONGOING PROJECT SUPPORT

WSP shall provide:

1. Schedule and document management, funding plans, reporting, communications, and phasing of public infrastructure and its intersection with private development.
2. Representation of the City for purposes of Project Infrastructure as described in this Agreement.
3. Coordination with other City consultants working on Project as directed by the Director of Public Works.

TASK 2.7 – TASK ADMINISTRATION

WSP shall:

1. Submit monthly invoices and monthly report.
2. Attend project meetings and stay in communication with the City’s Midtown Leadership Team.
3. Maintenance of project site and document management
 - All pertinent project records shall be tracked and stored in good order, all documents and presentations shall be professional, all invoices shall include a progress report and be timely.
 - Ensure that all work products and supporting documents are maintained in a repository readily accessible to all team members.

All documents and work products are the property of the City of Santa Fe and will be provided to the MRA Director by WSP upon termination of this agreement.in communication with the City’s Midtown Leadership Team.

3. Maintenance of project site and document management
 - All pertinent project records shall be tracked and stored in good order, all documents and presentations shall be professional, all invoices shall include a progress report and be timely.
 - Ensure that all work products and supporting documents are maintained in a repository readily accessible to all team members.

All documents and work products are the property of the City of Santa Fe and will be provided to the MRA Director by WSP upon termination of this agreement.

3. Standard of Performance; Licenses

A. The Contractor does hereby accept its designation as a professional service, rendering services related to Owner's Representation and Project Management Services for the City, as set forth in this Agreement. The Contractor represents that Contractor possesses the personnel, experience, and knowledge necessary to perform the services described under this Contract.

B. The Contractor agrees to obtain and maintain throughout the term of this Contract, all applicable professional and business licenses required by law, for itself, its employees, agents, representatives, and subcontractors.

4. Compensation

A. The City shall pay to the Contractor in full payment for services satisfactorily performed based upon milestones, such compensation not to exceed Ninety-thousand dollars, including gross receipts tax. The New Mexico gross receipts tax levied on the amounts payable under this Contract totaling Seven thousand Three-hundred Sixty-eight dollars and seventy-five cents (\$7,368.75) shall be paid by the City to the Contractor. **The total amount payable to the Contractor under this Agreement, including gross receipts tax and expenses, shall not exceed Ninety-thousand dollars (\$90,000). This amount is a maximum and not a guarantee that the work assigned to be performed by Contractor under this Contract shall equal the amount stated herein. The parties do not intend for the Contractor to continue to provide services without compensation when the total compensation amount is reached. Contractor is responsible for notifying the City when the services provided under this Contract reach the total compensation amount. In no event will the Contractor be paid for services provided in excess of the total compensation amount without this Contract being amended in writing prior to those services in excess of the total compensation amount being provided.**

B. Payment is subject to availability of funds pursuant to the Appropriations Paragraph set forth below and to any negotiations between the parties from year to year pursuant to Paragraph 1, Scope of Work, and to approval by the City. All invoices MUST BE received by the City no later than thirty (30) days after the termination of the Fiscal Year in which the services were delivered. Invoices received after such date WILL NOT BE PAID.

C. Payment in future fiscal years is subject to availability of funds pursuant to the Appropriations Paragraph set forth below and to any negotiations between the parties from year to year pursuant to Paragraph 1, Scope of Work, and to approval by the City. All invoices MUST BE received by the City no later than fifteen (15) days after the termination of the Fiscal Year in which the services were delivered. Invoices received after such date WILL NOT BE PAID.)

D. Contractor must submit a detailed statement accounting for all services performed and expenses incurred. If the City finds that the services are not acceptable, within thirty days after the date of receipt of written notice from the Contractor that payment is requested, it shall provide the Contractor a letter of exception explaining the defect or objection to the services, and outlining steps the Contractor may take to provide remedial action. Upon certification by the City that the services have been received and

accepted, payment shall be tendered to the Contractor within thirty days after the date of acceptance. If payment is made by mail, the payment shall be deemed tendered on the date it is postmarked. However, the City shall not incur late charges, interest, or penalties for failure to make payment within the time specified herein.

5. Term

THIS CONTRACT SHALL NOT BECOME EFFECTIVE UNTIL APPROVED BY THE CITY. This Contract shall terminate **December 31, 2027**, unless terminated pursuant to paragraph 4 (Termination), or paragraph 5 (Appropriations). The City reserves the right to renew this contract on an annual basis by mutual agreement not to exceed a total of four (4) years in accordance with NMSA 1978, Sections 13-1-150 through 152.

6. Termination

A. Grounds. The City may terminate this Agreement for convenience or cause. For contracts within their authority, the City Manager or their designee is authorized to provide the notice of termination, otherwise such notice of termination shall be provided by the Mayor, or their designee as authorized by the Governing Body. The Contractor may only terminate this Agreement based upon the City's uncured, material breach of this Agreement.

B. Notice; City Opportunity to Cure.

- 1) Except as otherwise provided in Paragraphs 7.A and 17, the City shall give Contractor written notice of termination at least thirty (30) days prior to the intended date of termination.
- 2) Contractor shall give City written notice of termination at least thirty (30) days prior to the intended date of termination, which notice shall (i) identify all the City's material breaches of this Agreement upon which the termination is based and (ii) state what the City must do to cure such material breaches. Contractor's notice of termination shall only be effective (i) if the City does not cure all material breaches within the thirty (30) day notice period or (ii) in the case of material breaches that cannot be cured within thirty (30) days, the City does not, within the thirty (30) day notice period, notify the Contractor of its intent to cure and begin with due diligence to cure the material breach.
- 3) Notwithstanding the foregoing, this Agreement may be terminated immediately upon written notice to the Contractor (i) if the Contractor becomes unable to perform the services contracted for, as determined by the City; (ii) if, during the term of this Agreement, the Contractor is suspended or debarred by the City; or (iii) the Agreement is terminated pursuant to Paragraph 6, "Appropriations", of this Agreement.

C. Liability. Except as otherwise expressly allowed or provided under this Agreement, the City's sole liability upon termination shall be to pay for acceptable work performed prior to the Contractor's receipt or issuance of a notice of termination; provided, however, that a notice of termination shall not nullify or otherwise affect either party's liability for pre-termination defaults under or breaches of this Agreement. The Contractor shall submit an invoice for such work within thirty (30) days of receiving or sending the notice of termination. THIS PROVISION IS NOT EXCLUSIVE AND DOES NOT WAIVE

THE CITY'S OTHER LEGAL RIGHTS AND REMEDIES CAUSED BY THE CONTRACTOR'S DEFAULT/BREACH OF THIS AGREEMENT.

7. Appropriations

The terms of this Contract are contingent upon sufficient appropriations and authorization being made by the City Council for the performance of this Contract. If sufficient appropriations and authorization are not made by the Governing Body, this Contract shall terminate immediately upon written notice being given by the City to the Contractor. The City's decision as to whether sufficient appropriations are available shall be accepted by the Contractor and shall be final. If the City proposes an amendment to the Contract to unilaterally reduce funding, the Contractor shall have the option to terminate the Contract or to agree to the reduced funding, within thirty (30) days of receipt of the proposed amendment.

8. Status of Contractor

The Contractor and its agents and employees are independent contractors performing construction services for the City and are not employees of the City. The Contractor and its agents and employees shall not accrue leave, retirement, insurance, bonding, use of City vehicles, or any other benefits afforded to employees of the City as a result of this Contract. The Contractor acknowledges that all sums received hereunder are reportable by the Contractor for tax purposes, including without limitation, self-employment and business income tax. The Contractor agrees not to purport to bind the City unless the Contractor has express written authority to do so, and then only within the strict limits of that authority.

9. Assignment

The Contractor shall not assign or transfer any interest in this Contract or assign any claims for money due or to become due under this Contract without the prior written approval of the City.

10. Subcontracting

The Contractor shall not subcontract any portion of the services to be performed under this Contract without the prior written approval of the City. No such subcontract shall relieve the primary Contractor from its obligations and liabilities under this Contract, nor shall any subcontract obligate direct payment from the City.

11. Release

Final payment of the amounts due under this Contract shall operate as a release of the City, its officers and employees from all payment liabilities, claims and obligations whatsoever arising from or under this Contract.

12. Confidentiality

Any confidential information provided to or developed by the Contractor in the performance of this Contract shall be kept confidential and shall not be made available to any individual or

organization by the Contractor without the prior written approval of the City.

13. Product of Service -- Copyright

All materials developed or acquired by the Contractor under this Contract shall become the property of the City and shall be delivered to the City no later than the termination date of this Contract. Nothing developed or produced, in whole or in part, by the Contractor under this Contract shall be the subject of an application for copyright or other claim of ownership by or on behalf of the Contractor.

14. Conflict of Interest; Governmental Conduct Act

A. The Contractor represents and warrants that it presently has no interest and, during the term of this Contract, shall not acquire any interest, direct or indirect, which would conflict in any manner or degree with the performance or services required under the Contract.

B. The Contractor further represents and warrants that it has complied with, and, during the term of this Contract, will continue to comply with, and that this Contract complies with all applicable provisions of the Governmental Conduct Act, Chapter 10, Article 16 NMSA 1978.

C. Contractor's representations and warranties in Paragraphs A and B of this Article 12 are material representations of fact upon which the City relied when this Contract was entered into by the parties. Contractor shall provide immediate written notice to the City if, at any time during the term of this Contract, Contractor learns that Contractor's representations and warranties in Paragraphs A and B of this Article 12 were erroneous on the effective date of this Contract or have become erroneous by reason of new or changed circumstances. If it is later determined that Contractor's representations and warranties in Paragraphs A and B of this Article 12 were erroneous on the effective date of this Contract or have become erroneous by reason of new or changed circumstances, in addition to other remedies available to the City and notwithstanding anything in the Contract to the contrary, the City may immediately terminate the Contract.

D. All terms defined in the Governmental Conduct Act have the same meaning in this section.

15. Amendment

A. This Agreement shall not be altered, changed, or amended except by instrument in writing executed by the parties hereto and all other required signatories.

B. If the City proposes an amendment to the Contract to unilaterally reduce funding due to budget or other considerations, the Contractor shall, within thirty (30) days of receipt of the proposed Amendment, have the option to terminate the Contract, pursuant to the termination provisions as set forth in Article 4 herein, or to agree to the reduced funding.

16. Entire Agreement.

This Agreement, together with any other documents incorporated herein by reference and all related Exhibits and Schedules constitutes the sole and entire agreement of the Parties with

respect to the subject matter of this Agreement, and supersedes all prior and contemporaneous understandings, agreements, representations, and warranties, both written and oral, with respect to the subject matter. In the event of any inconsistency between the statements in the body of this Agreement, and the related Exhibits and Schedules, the statements in the body of this Agreement shall control.

17. Merger

This Contract incorporates all the Agreements, covenants and understandings between the parties hereto concerning the subject matter hereof, and all such covenants, agreements, and understandings have been merged into this written contract.

Cooperative 13-1-135

This Contract is issued against the Cooperative Educational Services Master Agreement 2023-01-C211-ALL Design and Professional Services, Category 2 – Lot 1, Engineering and Consulting Services, established and maintained by Contractor, and through this language hereby incorporates this agreement by reference and is included in the order of precedence.

No prior Agreement or understanding, oral or otherwise, of the parties or their agents shall be valid or enforceable unless embodied in this Contract.

18. Penalties for violation of law

NMSA 1978, sections 13-1-28 through 13-1-199, imposes civil and criminal penalties for its violation. In addition, the New Mexico criminal statutes impose felony penalties for illegal bribes, gratuities, and kickbacks.

19. Equal Opportunity Compliance

The Contractor agrees to abide by all federal and state laws and rules and regulations, and Santa Fe City Code, pertaining to equal employment opportunity. In accordance with all such laws of the State of New Mexico, the Contractor assures that no person in the United States shall, on the grounds of race, religion, color, national origin, ancestry, sex, age, physical or mental handicap, or serious medical condition, spousal affiliation, sexual orientation or gender identity, be excluded from employment with or participation in, be denied the benefits of, or be otherwise subjected to discrimination under any program or activity performed under this Contract. If Contractor is found not to be in compliance with these requirements during the life of this Contract, Contractor agrees to take appropriate steps to correct these deficiencies.

20. Applicable Law

The laws of the State of New Mexico shall govern this Contract, without giving effect to its choice of law provisions. Venue shall be proper only in a New Mexico court of competent jurisdiction in accordance with NMSA 1978, section 38-3-2. By execution of this Contract, Contractor acknowledges and agrees to the jurisdiction of the courts of the State of New Mexico over any and all lawsuits arising under or out of any term of this Contract.

21. Workers Compensation

The Contractor agrees to comply with state laws and rules applicable to workers compensation benefits for its employees. If the Contractor fails to comply with the Workers Compensation Act and applicable rules when required to do so, this Contract may be terminated by the City.

22. Professional Liability Insurance

Contractor shall maintain professional liability insurance throughout the term of this Contract providing a minimum coverage in the amount required under the New Mexico Tort Claims Act. The Contractor shall furnish the City with proof of insurance of Contractor's compliance with the provisions of this section as a condition prior to performing services under this Contract.

23. Other Insurance

If the services contemplated under this Contract will be performed on or in City facilities or property, Contractor shall maintain in force during the entire term of this Contract, the following insurance coverage(s), naming the City as additional insured.

A. **Commercial General Liability** insurance shall be written on an occurrence basis and be as broad as ISO Form CG 00 01 with limits not less than \$2,000,000 per occurrence and \$2,000,000 in the aggregate for claims against bodily injury, personal and advertising injury, and property damage. Said policy shall include broad form Contractual Liability coverage and be endorsed to name the City of Santa Fe their officials, officers, employees, and agents as additional insureds.

B. **Broader Coverage and Limits.** The insurance requirements under this Contract shall be the greater of (1) the minimum coverage and limits specified in this Contract, or (2) the broader coverage and maximum limits of coverage of any insurance policy or proceeds available to the Named Insured. It is agreed that these insurance requirements shall not in any way act to reduce coverage that is broader or that includes higher limits than the minimums required herein. No representation is made that the minimum insurance requirements of this Contract are sufficient to cover the obligations of Contractor hereunder.

C. Contractor shall maintain the above insurance for the term of this Contract and name the City as an additional insured and provide for 30 days cancellation notice on any Certificate of Insurance form furnished by Contractor. Such certificate shall also specifically state the coverage provided under the policy is primary over any other valid and collectible insurance and provide a waiver of subrogation.

24. Records and Financial Audit

The Contractor shall maintain detailed time and expenditure records that indicate the date; time, nature and cost of services rendered during the Contract's term and effect and retain them for a period of three (3) years from the date of final payment under this Contract. The records shall be

subject to inspection by the City. The City shall have the right to audit billings both before and after payment. Payment under this Contract shall not foreclose the right of the City to recover excessive or illegal payments.

25. Indemnification

The Contractor shall indemnify and hold harmless the City from all actions, proceeding, claims, demands, costs, damages, attorneys' fees and all other liabilities and expenses of any kind from any source which may arise out of the performance of this Contract, caused by the negligent act or failure to act of the Contractor, its officers, employees, servants, subcontractors or agents, or if caused by the actions of any client of the Contractor resulting in injury or damage to persons or property during the time when the Contractor or any officer, agent, employee, servant or subcontractor thereof has or is performing services pursuant to this Contract. If any action, suit or proceeding related to the services performed by the Contractor or any officer, agent, employee, servant or subcontractor under this Contract is brought against the Contractor, the Contractor shall, as soon as practicable but no later than two (2) days after it receives notice thereof, notify the legal counsel of the City.

26. New Mexico Tort Claims Act

Any liability incurred by the City of Santa Fe in connection with this Contract is subject to the immunities and limitations of the New Mexico Tort Claims Act, Section 41-4-1, et. seq. NMSA 1978, as amended. The City and its "public employees" as defined in the New Mexico Tort Claims Act, do not waive sovereign immunity, do not waive any defense and do not waive any limitation of liability pursuant to law. No provision in this Contract modifies or waives any provision of the New Mexico Tort Claims Act.

27. Invalid Term or Condition

If any term or condition of this Contract shall be held invalid or unenforceable, the remainder of this Contract shall not be affected and shall be valid and enforceable.

28. Enforcement of Contract

A party's failure to require strict performance of any provision of this Contract shall not waive or diminish that party's right thereafter to demand strict compliance with that or any other provision. No waiver by a party of any of its rights under this Contract shall be effective unless express and in writing, and no effective waiver by a party of any of its rights shall be effective to waive any other rights.

29. Notices

Any notice required to be given to either party by this Contract shall be in writing and shall be delivered in person, by courier service or by U.S. mail, either first class or certified, return receipt requested, postage prepaid, as follows:

To the City:

Tim Farrell
Property Development Manager
City of Santa Fe Public Works
2651 Siringo Road, Building E
Santa Fe, NM 87504
tgfarrell@santafenm.gov
505-490-1659

To the Contractor:

Daniel Sims

Senior Vice President
WSP USA Inc
5411 Sky Center Drive, Building 650
Tampa, FL 33607
Dan.sims@wsp.com

30. Authority

If Contractor is other than a natural person, the individual(s) signing this Contract on behalf of Contractor represents and warrants that he or she has the power and authority to bind Contractor, and that no further action, resolution, or approval from Contractor is necessary to enter a binding contract.

31. Non-Collusion

In signing this Agreement, the Contractor certifies the Contractor has not, either directly or indirectly, entered into action in restraint of free competitive bidding in connection with this offer submitted to the City's Chief Procurement Officer.

32. Default/Breach

In case of Default and/or Breach by the Contractor, for any reason whatsoever, the City may procure the goods or services from another source and hold the Contractor responsible for any resulting excess costs and/or damages, including but not limited to, direct damages, indirect damages, consequential damages, special damages, and the City may also seek all other remedies under the terms of this Agreement and under law or equity.

33. Equitable Remedies

The Contractor acknowledges that its failure to comply with any provision of this Agreement will cause the City irrevocable harm and that a remedy at law for such a failure would be an inadequate remedy for the City, and the Contractor consents to the City's obtaining from a court of competent jurisdiction, specific performance, or injunction, or any other equitable relief in order to enforce such compliance. The City's rights to obtain equitable relief pursuant to this Agreement shall be in addition to, and not in lieu of, any other remedy that the City may have under applicable law, including, but not limited to, monetary damages.

34. Default and Force Majeure

The City reserves the right to cancel all, or any part of any orders placed under this Agreement without cost to the City, if the Contractor fails to meet the provisions of this Agreement and, except as otherwise provided herein, to hold the Contractor liable for any excess cost occasioned by the City due to the Contractor's default. The Contractor shall not be liable for any excess costs if failure to perform the order arises out of causes beyond the control and without the fault or negligence of the Contractor; such causes include, but are not restricted to, acts of God or the public enemy, acts of the State or Federal Government, fires, floods, epidemics, quarantine restrictions, strikes, freight embargoes, unusually severe weather and defaults of subcontractors due to any of the above, unless the City shall determine that the supplies or services to be furnished by the subcontractor were obtainable from other sources in sufficient time to permit the Contractor to meet the required delivery scheduled. The rights and remedies of the City provided in this Clause shall not be exclusive and are in addition to any other rights now being provided by law or under this Agreement.

[THIS SPACE INTENTIONALLY LEFT BLANK]

IN WITNESS WHEREOF, the Parties have executed this Contract as of the date of the signature by the required approval authorities below.

CITY OF SANTA FE:

John Blair
John Blair (Feb 20, 2024 14:19 MST)

JOHN BLAIR,
CITY MANAGER

DATE: Feb 20, 2024

CONTRACT

Daniel Sims

DANIEL SIMS,
SENIOR VICE PRESIDENT

DATE: 1/18/24

CRS#: 01195458002

Registration #: 230689

ATTEST:

Geralyn Cardenas
Geralyn Cardenas (Feb 21, 2024 09:31 MST)

GERALYN CARDENAS, INTERIM CITY CLERK
XIV

CITY ATTORNEY'S OFFICE:

Kevin L. Nault
Kevin L. Nault (Feb 1, 2024 14:32 MST)

ASSISTANT CITY ATTORNEY

APPROVED FOR FINANCES:

Emily K. Oster
Emily K. Oster (Feb 19, 2024 18:11 MST)

EMILY OSTER, FINANCE DIRECTOR

5250610/572960 AH
Org. Name/Org#: AH



City of Santa Fe
Treasury Department
200 Lincoln Ave.
Santa Fe, New Mexico 87504-0909
505-955-6551

BUSINESS REGISTRATION

Business Name: WSP USA INC.
DBA: WSP USA INC.

Business Location: 2440 LOUISIANA BLVD STE. 400
ALBUQUERQUE, NM 87110

Owner: Jodi Miller

License Number: 230689

Issued Date: August 16, 2023

Expiration Date: August 16, 2024

CRS Number: 01195458002

License Type: Business License - Renewable

Classification: Out of Jurisdiction Business License

Fees Paid: \$10.00

WSP USA INC.
4139 Oregon Pike Oregon Pike
EPHRATA, PA 17522

THIS IS NOT A CONSTRUCTION PERMIT OR SIGN PERMIT.
APPROPRIATE PERMITS MUST BE OBTAINED FROM THE CITY
OF SANTA FE BUILDING PERMIT DIVISION PRIOR TO
COMMENCEMENT OF ANY CONSTRUCTION OR THE
INSTALLATION OF ANY EXTERIOR SIGN.

THIS REGISTRATION/LICENSE IS NOT TRANSFERRABLE TO
OTHER BUSINESSES OR PREMISES.

TO BE POSTED IN A CONSPICUOUS PLACE



CERTIFICATE OF LIABILITY INSURANCE

DATE (MM/DD/YYYY)

11/8/2023

THIS CERTIFICATE IS ISSUED AS A MATTER OF INFORMATION ONLY AND CONFERS NO RIGHTS UPON THE CERTIFICATE HOLDER. THIS CERTIFICATE DOES NOT AFFIRMATIVELY OR NEGATIVELY AMEND, EXTEND OR ALTER THE COVERAGE AFFORDED BY THE POLICIES BELOW. THIS CERTIFICATE OF INSURANCE DOES NOT CONSTITUTE A CONTRACT BETWEEN THE ISSUING INSURER(S), AUTHORIZED REPRESENTATIVE OR PRODUCER, AND THE CERTIFICATE HOLDER.

IMPORTANT: If the certificate holder is an ADDITIONAL INSURED, the policy(ies) must have ADDITIONAL INSURED provisions or be endorsed. If SUBROGATION IS WAIVED, subject to the terms and conditions of the policy, certain policies may require an endorsement. A statement on this certificate does not confer rights to the certificate holder in lieu of such endorsement(s).

PRODUCER Arthur J. Gallagher Risk Management Services, LLC 300 Madison Avenue, 28th Floor New York NY 10017	CONTACT NAME: AJG Sevice Team	
	PHONE (A/C, No, Ext): 212-994-7020	FAX (A/C, No): 212-994-7074
E-MAIL ADDRESS: GGB.WSPUS.CertRequest@ajg.com		
INSURER(S) AFFORDING COVERAGE		NAIC #
INSURER A: QBE Specialty Insurance Company		11515
INSURER B:		
INSURER C:		
INSURER D:		
INSURER E:		
INSURER F:		

INSURED WSPGL0B-01
 WSP USA Inc.
 One Penn Plaza
 New York, NY 10119

COVERAGES

CERTIFICATE NUMBER: 1318051649

REVISION NUMBER:

THIS IS TO CERTIFY THAT THE POLICIES OF INSURANCE LISTED BELOW HAVE BEEN ISSUED TO THE INSURED NAMED ABOVE FOR THE POLICY PERIOD INDICATED. NOTWITHSTANDING ANY REQUIREMENT, TERM OR CONDITION OF ANY CONTRACT OR OTHER DOCUMENT WITH RESPECT TO WHICH THIS CERTIFICATE MAY BE ISSUED OR MAY PERTAIN, THE INSURANCE AFFORDED BY THE POLICIES DESCRIBED HEREIN IS SUBJECT TO ALL THE TERMS, EXCLUSIONS AND CONDITIONS OF SUCH POLICIES. LIMITS SHOWN MAY HAVE BEEN REDUCED BY PAID CLAIMS.

INSR LTR	TYPE OF INSURANCE	ADDL INSD	SUBR WVD	POLICY NUMBER	POLICY EFF (MM/DD/YYYY)	POLICY EXP (MM/DD/YYYY)	LIMITS
	COMMERCIAL GENERAL LIABILITY <input type="checkbox"/> CLAIMS-MADE <input type="checkbox"/> OCCUR GEN'L AGGREGATE LIMIT APPLIES PER: <input type="checkbox"/> POLICY <input type="checkbox"/> PRO-JECT <input type="checkbox"/> LOC OTHER:						EACH OCCURRENCE \$ DAMAGE TO RENTED PREMISES (Ea occurrence) \$ MED EXP (Any one person) \$ PERSONAL & ADV INJURY \$ GENERAL AGGREGATE \$ PRODUCTS - COMP/OP AGG \$ \$
	AUTOMOBILE LIABILITY <input type="checkbox"/> ANY AUTO <input type="checkbox"/> OWNED AUTOS ONLY <input type="checkbox"/> SCHEDULED AUTOS <input type="checkbox"/> HIRED AUTOS ONLY <input type="checkbox"/> NON-OWNED AUTOS ONLY						COMBINED SINGLE LIMIT (Ea accident) \$ BODILY INJURY (Per person) \$ BODILY INJURY (Per accident) \$ PROPERTY DAMAGE (Per accident) \$ \$
	UMBRELLA LIAB <input type="checkbox"/> OCCUR EXCESS LIAB <input type="checkbox"/> CLAIMS-MADE DED RETENTION \$						EACH OCCURRENCE \$ AGGREGATE \$ \$
	WORKERS COMPENSATION AND EMPLOYERS' LIABILITY ANY PROPRIETOR/PARTNER/EXECUTIVE OFFICER/MEMBER EXCLUDED? (Mandatory in NH) If yes, describe under DESCRIPTION OF OPERATIONS below	<input type="checkbox"/> Y <input type="checkbox"/> N	<input type="checkbox"/> N/A				<input type="checkbox"/> PER STATUTE <input type="checkbox"/> OTHER E.L. EACH ACCIDENT \$ E.L. DISEASE - EA EMPLOYEE \$ E.L. DISEASE - POLICY LIMIT \$
A	Professional Liability CLAIMS-MADE			QPL0022630	11/1/2023	10/31/2024	Per Claim \$2,000,000 Aggregate \$2,000,000

DESCRIPTION OF OPERATIONS / LOCATIONS / VEHICLES (ACORD 101, Additional Remarks Schedule, may be attached if more space is required)

THIRTY (30) DAYS NOTICE OF CANCELLATION

RE: Project Number: 31000712.000. Project Description: Owner's Representative and Project Management Services for Midtown Redevelopment.

CERTIFICATE HOLDER**CANCELLATION**

City of Santa Fe
 PO Box 909
 Santa Fe NM 87504

SHOULD ANY OF THE ABOVE DESCRIBED POLICIES BE CANCELLED BEFORE THE EXPIRATION DATE THEREOF, NOTICE WILL BE DELIVERED IN ACCORDANCE WITH THE POLICY PROVISIONS.

AUTHORIZED REPRESENTATIVE

© 1988-2015 ACORD CORPORATION. All rights reserved.

CITY OF SANTA FE PROCUREMENT CHECKLIST



Contractor Name: WSP USA, Inc

Procurement/contract Title: Owner's Representative and Project Management

Procurement Method/Vehicle: Sole Source State Price Agreement/Existing Cooperative Request For Proposals(RFP) Invitation To Bid (ITB) Exempt: 13-1-98
 Small Purchase (Contract Under \$60,000) Other: _____

Requesting Department: Public Works/Facilities Div **Staff Name:** Tim Farrell

Procurement Requirements:

Procurement files shall be maintained for all purchases and contracts, regardless of the method of procurement. The procurement files shall contain the basis on which the awards are made, all submitted bids/proposals, all evaluation materials (bid tabs or Evaluation Committee Reports), scoresheets, quotations, and all other documentation related to or prepared in conjunction with evaluations, negotiations, and the award processes. The procurements shall contain written determinations from the Requesting Departments, signed by the Chief Procurement Officers (this document), setting forth the reasoning for the contract award decisions before submitting them to the Committees.

REQUIRED DOCUMENTS FOR APPROVAL BY PURCHASING (CPD)

YES	N/A		YES	N/A	
<input checked="" type="checkbox"/>	<input type="checkbox"/>	Written Determination (srvs)	<input type="checkbox"/>	<input checked="" type="checkbox"/>	Quote(s) (3 Valid & Current for Over 20k)
<input type="checkbox"/>	<input checked="" type="checkbox"/>	RFP - Confidential info to be provided to GB by CPD Buyer	<input checked="" type="checkbox"/>	<input type="checkbox"/>	BAR
<input type="checkbox"/>	<input checked="" type="checkbox"/>	ITB (include bid tab)	<input type="checkbox"/>	<input checked="" type="checkbox"/>	FIR
<input type="checkbox"/>	<input checked="" type="checkbox"/>	Other: _____	<input checked="" type="checkbox"/>	<input type="checkbox"/>	Certificate of Insurance (srvs)
<input checked="" type="checkbox"/>	<input type="checkbox"/>	Cooperative Agreements and GSAs and Statewide Price Agreements (include the cover page to show valid date, s			
<input checked="" type="checkbox"/>	<input type="checkbox"/>	Horizon Declination or Screenshot of horizonsofnewmexico.org/services.html (srvs)			
<input checked="" type="checkbox"/>	<input type="checkbox"/>	Summary of Contract (only on contracts)			
<input checked="" type="checkbox"/>	<input type="checkbox"/>	Current Santa Fe Business Registration (or Exemption if no tax)			
<input checked="" type="checkbox"/>	<input type="checkbox"/>	Executed Contract or Price Agreement (legal and contractor must sign before purchasing approves)			
<input type="checkbox"/>	<input checked="" type="checkbox"/>	Chief Procurement Officer (or designee) Approval for Exempt from Procurement (use memo on our site)			
<input type="checkbox"/>	<input checked="" type="checkbox"/>	Evaluation Committee Report (RFPs only)			
<input type="checkbox"/>	<input checked="" type="checkbox"/>	Signed Sole Source Determination, Vendor Written Quote, SS Letter from Contractors, and 30 Days Email			
<input type="checkbox"/>	<input checked="" type="checkbox"/>	>20k = Memo addressed to City Manager (Under 150K) Committees/City Council (Over 150K)			

Tim Farrell
Department Point of Contact

Property Development Manager 2/12/2024
Title Date

Regina Wheeler
Department Director

2/12/2024
Date

JorAnn Lovato Montano
Chief Procurement Officer

Feb 19, 2024
Date

N/A
ITT Representative

Title Date



CITY OF SANTA FE

Memorandum

Date: January 22, 2026

To: Governing Body, Public Works and Utilities Committee, and Finance Committee

From: Carol Swenson, Public Works Business Operations Manager

Via: Sam Burnett, Interim Public Works Director

RE: Authorizing Representatives and Agents for NMED Agreement 25-J2459-GF

EXECUTIVE SUMMARY:

This Resolution designates authorized representatives and agents for an agreement with New Mexico Environment Department (NMED) regarding Agreement SAP 25-J2459-GF (“Grant Agreement”). The Agreement makes available one hundred thousand dollars (\$100,000), appropriated by the New Mexico State Legislature for a project to plan, design, and construct a wastewater treatment facility in Santa Fe.

BACKGROUND:

NMED, through Article XI.B.(e) of the Grant Agreement, requires that the City of Santa Fe (“City”) as the grantee, agree that the “governing body has duly adopted or passed as an official act a resolution, motion, or similar action authorizing the person identified as the official representative of the Grantee to sign the Agreement and to sign and submit Requests for Payment on behalf of the Grantee”. Adoption of this Resolution will satisfy this requirement and allow the City to enter into the Grant Agreement. The Grant Agreement will be presented to the Governing Body in an action separate from this Resolution; and this Resolution will not be implicated if the Governing Body does not later approve the grant agreement.

ATTACHMENTS:

Resolution
FIR

1
2
3
4
5
6
7
8
9
10
11
12
13
14
15
16
17
18
19
20
21
22
23
24

CITY OF SANTA FE, NEW MEXICO

RESOLUTION NO. 2026-__

INTRODUCED BY:

Councilor Amanda Chavez

A RESOLUTION

AUTHORIZING CITY OF SANTA FE REPRESENTATIVES AND AGENTS TO SIGN AGREEMENTS AND REQUESTS FOR PAYMENT REGARDING NEW MEXICO ENVIRONMENT DEPARTMENT, FOR GRANT AGREEMENT NUMBER SAP 25-J2459-GF TO PLAN, DESIGN, AND CONSTRUCT A WASTEWATER TREATMENT FACILITY.

WHEREAS, in the Laws of 2025, Chapter 159, Section 28, Subsection 108, the Legislature made an appropriation to the New Mexico Environment Department (“NMED”), for funds from which NMED is making available to the City of Santa Fe (“Grantee” or “City”) through Grant Agreement number SAP 25-J2459-GF (“Agreement”), incorporated as Attachment A, in the amount of one hundred thousand dollars (\$100,000), to plan, design, and construct a wastewater treatment facility in the city of Santa Fe, in Santa Fe County (the “project”); and

WHEREAS, Article XI(B)(e) of the Agreement states that the “Grantee’s governing body has duly adopted or passed as an official act a resolution, motion, or

1 similar action authorizing the person identified as the official representative of the Grantee
2 to sign and submit Requests for Payment on behalf of Grantee” and adopting this
3 resolution will satisfy this requirement.

4 **NOW, THEREFORE, BE IT RESOLVED BY THE GOVERNING BODY OF THE**
5 **CITY OF SANTA FE** that the following provisions shall apply to the Agreement:

6 A. The person listed below, or their successor, is the Grantee’s official representative
7 authorized to sign the Agreement:

8 Grantee: City of Santa Fe
9 Name: David Chapman
10 Title: Grants Administrator
11 Address: PO Box 909
12 Santa Fe, NM 87504-0909
13 Email: dachapman@santafenm.gov
14 Telephone: (505) 955-6251

15 B. The person listed below, or their successor, is the Grantee’s Fiscal Office or Fiscal
16 Agent concerning reviewing and signing Requests for Payments for permissible
17 expenditures:

18 Grantee: City of Santa Fe
19 Name: Erika Lujan
20 Title: Grant Manager
21 Address: 200 Lincoln Avenue
22 Santa Fe, NM 87051
23 Email: evlujan@santafenm.gov
24 Telephone: (505) 479-1334
25

1
2
3
4
5
6
7
8
9
10
11
12
13
14
15
16
17
18
19
20
21
22
23
24
25

PASSED, APPROVED, and ADOPTED this _____ day of _____, 2026.

MICHAEL GARCIA, MAYOR

ATTEST:

GERALYN CARDENAS, INTERIM CITY CLERK

APPROVED AS TO FORM:

Marcos Martinez
Marcos Martinez (Jan 23, 2026 08:26:27 MST)
MARCOS MARTÍNEZ, INTERIM CITY ATTORNEY

EXHIBIT A

NEW MEXICO CAPITAL OUTLAY GRANT AGREEMENT CAPITAL APPROPRIATION PROJECT

THIS AGREEMENT is made and entered into by and between the State of New Mexico, New Mexico Environment Department, (“**Department**”) and City of Santa Fe, (“**Grantee**”) (individually “**Party**” and collectively “**Parties**”). This Agreement shall be effective as of the date the Department executes it (“**Effective Date**”).

WITNESSETH

WHEREAS, in the Laws of 2025, Chapter 159, Section 28, Subsection 108, the Legislature made an appropriation to the Department, funds from which the Department is making available to the Grantee pursuant to this Agreement; and

WHEREAS, the Department is granting to Grantee, and the Grantee is accepting the grant of funds from this appropriation, in accordance with the terms and conditions of this Agreement;

NOW, THEREFORE, in consideration of the mutual covenants and obligations contained herein, the parties hereby mutually agree as follows:

AGREEMENT

I. PROJECT DESCRIPTION, GRANT AMOUNT, AND REVERSION

- A. SAP 25-J2459-GF (“**Project**”) **June 30, 2029** (“**Reversion Date**”). Laws of 2025, Chapter 159, Section 28, Subsection 108, One Hundred Thousand Dollars, (\$100,000.00), to plan, design and construct a wastewater treatment facility in Santa Fe in Santa Fe county;.
- B. Grantee’s total reimbursements shall not exceed One Hundred Thousand Dollars \$100,000.00 (“**Appropriation Amount**”) minus the allocation for Art in Public Places (“**AIPP amount**”), if applicable, No Dollars, \$0.00, which equals One Hundred Thousand Dollars, \$100,000.00 (“**Adjusted Appropriation Amount**”).
- C. In the event of a conflict among the Appropriation Amount, the Reversion Date, as defined herein and/or the purpose of the Project, as set forth in this Agreement, and the corresponding appropriation language in the laws cited above in this Article I, the language of the laws cited herein shall control.

The information contained in Article I is referred to collectively as the “**Project Description**.”

II. DISBURSEMENT LIMITATION

- A. Upon the Effective Date, the Grantee shall submit to the Department a comprehensive procurement plan and expenditure plan, detailing a Project timeline with milestones, required procurements, and identifying expected expenditures per milestone (collectively, “**Project Budget**”). The Department shall review and approve the Project Budget by approving a Notice of Department’s Obligation (“**Notice of Obligation**”), in accordance with the Project Description, a sample of which is attached hereto as **Exhibit B** and incorporated herein by reference. After receipt of approved Notice of Obligation, the Grantee may be reimbursed for allowable costs up to the Adjusted Appropriation Amount. This Agreement and any reimbursements up to the Adjusted Appropriation Amount are expressly conditioned upon the following:
 - a. Irrespective of any Notice of Obligation, Grantee’s expenditures shall be made in accordance with the Project Budget, on or before the Reversion Date and/or, if applicable, any Early Termination Date; and

- b. The total amount received by Grantee shall not exceed the lesser of:
 - i. the Adjusted Appropriation Amount identified in Article I (B) herein; or
 - ii. the total of all amounts stated in the Notice(s) of Obligation evidencing the Department has received and accepted Grantee's Third Party Obligation(s); and
 - c. Grantee's expenditures are made and accounted for pursuant to the State Procurement Code, State's Model Accounting Practices, and execution of binding written obligations or purchase orders with third-party contractors or vendors for the provision of services, including professional services, or the purchase of tangible personal property and real property for the Project ("**Third Party Obligations**"); and
 - d. Grantee's submittal of timely Requests for Payment and supporting documentation in accordance with the procedures set forth in this Agreement; and
 - e. In the event capital assets acquired with Project funds are to be sold, leased, or licensed to or operated by a private entity, the sale, lease, license, or operating agreement:
 - i. must be approved by the applicable oversight entity (if any) in accordance with §§ 13-6-2, 13-6-2.1, and 13-6-3; or
 - ii. If no oversight entity is required to approve the transaction, the Department of Finance and Administration's Infrastructure Planning Development Division (IPDD) must approve it as complying with the law.
- B. Prior to the sale, lease, license, or operating agreement being approved pursuant to Articles II(A)(e) (i) or (ii) herein, the Department may, in its sole and absolute discretion, unless inconsistent with State Board of Finance imposed conditions, reimburse Grantee for necessary expenditures incurred to develop the Project sufficiently to make the sale, lease, license, or operating agreement commercially feasible, limited to planning and design expenditures; and
- C. Grantee's submission of documentation of all Third Party Obligations and amendments thereto (including terminations) to the Department and the Department's issuance of a Notice of Obligation for a particular amount in accordance with the terms of this Agreement shall be governed by the following:
- a. Grantee is authorized to budget the particular amount set forth in the Notice of Obligation, execute the Third Party Obligation, and request the Third Party to begin work after issuance of a Notice of Obligation by the Department.
 - b. Grantee acknowledges and agrees that any Third Party Obligations agreed to prior to receiving a Notice of Obligation are its sole responsibility.
 - c. Grantee shall submit to the Department one copy of all Third Party Obligations and amendments thereto (including terminations) as soon as possible after execution by the Third Party but prior to execution by the Grantee.
 - d. Department may, in its sole and absolute discretion, issue a Notice of Obligation for the particular amount of a Third Party Obligation that only obligates the Department to reimburse Grantee's expenditures made on or before the Reversion Date or an Early Termination Date. The current Notice of Obligation form is incorporated herein and attached hereto as **Exhibit B**.
- D. Grantee shall provide all necessary qualified personnel, materials, and facilities to implement the Project. The Grantee shall finance its share (if any) of the costs of the Project, including all Project overruns.
- E. Prior to entering into this Agreement, the Department conducted a risk assessment on the Grantee and a project readiness review for the Project. In accordance with State Model Accounting Practices, FIN 9.2, if the Department determines that the expenditure of Project funds by the Grantee requires special conditions, those conditions are identified and listed in **Exhibit C**, which is attached and incorporated by reference. The Parties agree that, to the extent the Department, in its sole and absolute discretion, determines additional special conditions are necessary or that existing special conditions are no longer

required, it may update **Exhibit C** from time to time without the need for a formal amendment of this Agreement.

- F. Project funds shall not be used for purposes other than those authorized by the Department in accordance with the Project Description.
- G. Project funds cannot be used to reimburse the Grantee for indirect Project costs unless specifically allowed by law.

III. NOTICES

The following provisions shall apply whenever written notices, including written decisions, are to be given or received related to this Agreement.

- A. The Grantee designates the person(s) listed below, or their successor, as their official representative(s) concerning all matters related to this Agreement:

Grantee: City of Santa Fe
Name: David Chapman
Title: Grants Administrator
Address: PO Box 909 Santa Fe, NM 87504
Email: dachapman@santafenm.gov
Telephone: 505-955-6251

- B. The Grantee designates the person(s) listed below, or their successor, as their Fiscal Officer or Fiscal Agent concerning all matters related to this Agreement:

Grantee: City of Santa Fe
Name: Erika Lujan
Title: Grant Manager
Address: PO Box 909 Santa Fe, NM 87504
Email: evlujan@santafenm.gov
Telephone: 505-479-1334

- C. The Department designates the persons listed below, or their successors, as the Points of Contact for matters related to this Agreement.

Environment Department
Name: Roy Hubbard
Program Administrator
NMENV-cpbsap@state.nm.us or roy.hubbard@env.nm.gov
Telephone: 505-670-3615

Environment Department
Name: Andrea Telmo
Project Manager
Email: andrea.telmo@env.nm.gov
Telephone: 505-618-0484

Environment Department

Sara Rhoton
Technical Section Manager
Sara.rhoton@env.nm.gov
Telephone: 505-469-2687

The Parties agree that all notices, including written decisions, related to this Agreement shall be sent to the persons named above by email or regular mail. For mailings, notices shall be deemed to have been given and received upon the date of the receiving party's actual receipt or five (5) calendar days after mailing, whichever shall first occur. In the case of email transmissions, the notice shall be deemed to have been given and received on the date reflected on the delivery receipt of the email.

IV. TERM & DEADLINE TO EXPEND FUNDS

- A. The term of this Agreement shall begin on the Effective Date and terminate on the 30th day of June during the calendar year of the Reversion Date unless Terminated Before Reversion Date ("**Early Termination**") pursuant to Article V herein (collectively "**Term**").
- B. The Project's funds must be expended on or before the Reversion Date and, if applicable, the Early Termination Date of this Agreement.
 - a. For purposes of this Agreement, it is not sufficient for the Grantee to encumber the Project funds on its books on or before the Reversion Date or Early Termination Date.
 - b. For purposes of this Agreement, an expenditure of funds has occurred on the date the particular quantity of goods is delivered to and received by the Grantee, title to the goods is transferred to the Grantee, and/or as of the date particular services are rendered to and accepted by the Grantee.
 - c. For purposes of this Agreement, an encumbrance of funds pursuant to a contract or purchase order with a third party does not qualify as an expenditure.

V. EARLY TERMINATION

- A. General Provision. The Department may terminate this Agreement before the Reversion Date based on the Completion of the Project, Complete Expenditure of the Adjusted Appropriation, and/or Violation of this Agreement. Early Termination hereunder includes:
 - a. Termination due to completion of the Project before the Reversion Date;
 - b. Termination due to complete expenditure of the Adjusted Appropriation Amount before the Reversion Date;
 - c. Termination for violation of the terms of this Agreement; or
 - d. Termination for suspected mishandling of public funds, including but not limited to fraud, waste, abuse, and conflicts of interest.
- B. Non-appropriation. This Agreement is expressly contingent upon the New Mexico State Legislature making sufficient appropriations and authorizations for the Project Description.
 - a. If the Legislature does not appropriate the Appropriation Amount, this Agreement shall terminate upon the Department giving the Grantee written notice of such termination. Such termination shall be effective as of the effective date of the law making the non-appropriation.
 - i. The Department's decision as to whether sufficient appropriations or authorizations are available shall be final. Grantee hereby waives any rights to assert an impairment of

contract claim against the State of New Mexico in the event of Early Termination of this Agreement.

- b. As used herein, “non-appropriate” or “non-appropriation” includes the following actions by the New Mexico Legislature:
 - i. Deauthorization, reauthorization, or revocation of a prior authorization.

C. Grant Disbursements in the Event of Early Termination. In the event of Early Termination, the Department’s sole and absolute obligation to reimburse the Grantee is expressly conditioned upon the limitations set forth in Article II above.

D. Notice. Either Party may terminate this Agreement prior to the Reversion Date by providing the other Party with a minimum of fifteen (15) days advance written notice of the Early Termination. Grantee hereby waives any rights to assert an impairment of contract claim against the State of New Mexico in the event of Early Termination of this Agreement by the Department.

VI. SUSPENSION OF NEW OR FURTHER OBLIGATIONS

A. Department, in its sole and absolute discretion, may provide written notice to Grantee to suspend entering into further obligations. Upon the receipt of such written notice by the Grantee:

- a. Grantee shall immediately suspend entering into new or further written obligations with third parties;
- b. Department will suspend the issuance of any new or further Notice of Obligation under this Agreement; and
- c. Department may direct the Grantee to implement a corrective action plan in accordance with Article VI (D) herein.

B. In the event of Suspension of this Agreement, the Department’s sole and absolute obligation to reimburse the Grantee is expressly conditioned upon the limitations set forth in Article II herein.

C. A suspension of new or further obligations under this Agreement shall remain in effect unless or until the date the Grantee receives written notice given by the Department informing the Grantee that the Suspension has been lifted or that the Agreement has been Early Terminated in accordance with Article V herein. If the Suspension is lifted, the Department will consider further requests for a Notice of Obligation.

D. Corrective Action Plan in the Event of Suspension. Where the Department, in its sole and absolute discretion, directs Grantee to suspend entering into new or further written obligations with third parties pursuant to Article VI(A), the Department may, but is not obligated to, require the Grantee to develop and implement a written corrective action plan to remedy the grounds for the Suspension.

- a. Such a corrective action plan must be approved by the Department and be signed by the Grantee.
- b. Failure to sign a corrective action plan or meet the terms and deadlines set forth in the signed corrective action plan is hereby deemed a violation of the terms of this Agreement for purposes of Early Termination, Article V(A)(c).
- c. A corrective action plan shall be in addition to, and not in lieu of, any other equitable or legal remedy authorized hereunder or at law, including but not limited to Early Termination.

VII. AMENDMENTS

Unless expressly stated otherwise herein, this Agreement shall not be altered, changed, or amended except by an instrument in writing duly executed by both parties hereto with the same formalities as this agreement.

VIII. REPORTING

A. Database Reporting

- a. Grantee shall provide the Department with quarterly reports of Project activity, entering the required Project information directly into a database required by the Department.
- b. Additionally, Grantee shall certify on each Request for Payment form, attached hereto as **Exhibit A** and incorporated herein, that all information provided in the database is true and accurate, updates to the database have been maintained, and all Project activity complies with applicable law and the terms of this Agreement.
- c. Grantee hereby acknowledges that failure to perform and/or certify updates to the database will jeopardize the reimbursement of funds. The Department shall give Grantee a minimum of fourteen (14) days' advance written notice of any changes to the information the Grantee is required to report.
- d. At the Department's discretion, all reports required hereunder may be directed to and facilitated through an electronic database.
- e. Quarterly reports shall be due on the last day of the month, that is, 30 days prior to the end of the quarter following the execution of this Agreement by the Department and ending during the quarter of the submission of the final request for reimbursement for the Project, or the following quarter.

B. Requests for Additional Information/Project Inspection

During the term of this Agreement and during the period of time during which the Grantee must maintain records pursuant to Article VIII, the Department may:

- i. request such additional information regarding the Project as it deems necessary; and
- ii. conduct, at reasonable times and upon reasonable notice, onsite inspections of the Project.

Grantee shall respond to such requests for additional information within a reasonable period of time, as established by the Department.

B. Requests for Additional Information/Project Inspection

- a. During the term of this Agreement and the Record Retention Period, the Department may:
 - i. Request additional information regarding the Project as it deems necessary and
 - ii. Conduct on-site inspections of the Project at reasonable times and upon reasonable notice.
- b. Grantee shall respond to such requests for additional information within the time established by the Department.

IX. REQUEST FOR PAYMENT PROCEDURES

A. Grantee shall request payment by submitting the form attached hereto as **Exhibit A**. Payment requests are subject to the following procedures:

- a. Each Request for Payment must be in accordance with the Project Budget and contain proof of payment by the Grantee or liabilities incurred by the Grantee.
 - i. Proof of payment must demonstrate the validity of an expenditure or liabilities incurred by Grantee.

- ii. However, Grantee may be reimbursed for unpaid liabilities only if the Department, in its sole and absolute discretion, agrees to do so and in accordance with any special conditions imposed by the Department.
 - iii. The Grantee shall make payment to those contractors or vendors within five (5) business days from the date of receiving reimbursement from the Department or in a shorter period than the Department may prescribe in writing.
 - iv. The Department reserves the right to make such payments directly to the contractors or vendors as a special condition under this Agreement.
 - v. The Grantee is required to certify to the Department proof of payment to the third-party contractor or vendor within five (5) business days from the date the Department reimburses the Grantee.
- B. Until the Project is fully planned, designed, and all necessary procurements identified in the Project Budget are completed, Grantee's reimbursements will be limited to the planning, design, and procurement costs outlined in the Project Budget. Once the planning, designing, and procuring stages are complete, the Grantee must obligate at least ten percent (10%) of the Adjusted Appropriation Amount within one (1) year and must have utilized at least eighty-five percent (85%) of the Adjusted Appropriation Amount six (6) months before the reversion date.
- C. Deadlines. Grantee shall submit requests for Payments to the Department on the earlier of:
- a. Immediately as Grantee receives them, but at a maximum of thirty (30) days from when Grantee incurred the expenditure or liability; or
 - b. Twenty (20) days from the date of Early Termination or Reversion Date for expenditures or liabilities incurred before the Early Termination date or Reversion Date.
- D. Grantee's failure to abide by the requirements set forth in Article II and Article IX herein may result in the denial of its Request for Payment. Department reserves the right to reject a payment request for the Project unless and until it is satisfied that the expenditures or liabilities are for permissible purposes within the meaning of the Project Description, identified within the Project Budget, and that the Grantee is otherwise in compliance with this Agreement.
- a. Department's authority to reject any Request for Payment is in addition to, and not in lieu of, any other legal or equitable remedy available to the Department under this Agreement, at law, or in equity.

X. PROJECT CONDITIONS AND RESTRICTIONS

- A. The following general conditions and restrictions shall apply to the Project:
- a. The Project's funds must be spent in accordance with all applicable state laws, regulations, policies, and guidelines, including, but not limited to, the State Procurement Code.
 - b. The Project's expenditures and liabilities must be accounted for in accordance with the State's Model Accounting Practices, as amended from time to time.
 - c. The Project must be implemented in accordance with the New Mexico Public Works Minimum Wage Act, Section 13-4-10 through 13-4-17 NMSA 1978, as applicable.
 - d. The Project must provide a public benefit above and beyond any incidental benefit to private entities in accordance with applicable law, including, but not limited to, Article IX, Section 14 of the Constitution of the State of New Mexico.

- e. Without prior written approval from the Department and State Board of Finance, for the useful life of any asset purchased under this Agreement, Grantee shall not convert any property acquired, built, renovated, repaired, designed, or developed with Project funds to uses other than those specified in the Project Description.
 - i. In addition to other remedies available at law or in equity, any disposal or conversion of property acquired, built, renovated, repaired, designed, or developed with Project funds without the Department's and the Board of Finance's express written approval will trigger the Department's right to reimbursement from Grantee of the Appropriated Amount, transfer proceeds from any disposition of property to the State, or otherwise provide consideration to the State for the Appropriated Amounts.
- f. Grantee shall comply with all applicable federal and state laws, rules, and regulations pertaining to civil rights and equal employment opportunity.
 - i. In accordance with all such laws, rules, and regulations, the Grantee agrees to assure that no person shall, on the grounds of race, color, national origin, sex, sexual preference, age, or handicap, be excluded from participation in the Project, use of the Project, employment with Grantee, or otherwise be denied benefits/subject to discrimination for any activity performed under this Agreement.
- g. Where the Department, in its sole and absolute discretion, determines Grantee has failed to comply with the above conditions and restriction, Grantee agrees to take appropriate steps to correct any deficiencies immediately. The Grantee's failure to implement such appropriate steps within a reasonable time, but no longer than thirty (30) days after notice from the Department, constitutes a breach of this Agreement and grounds for Early Termination.

XI. REPRESENTATIONS AND WARRANTIES

A. Reliance by Department.

- a. Grantee expressly acknowledges that the Department relies on the representations and warranties made by Grantee in this Agreement. Grantee acknowledges that such representations and warranties are a material inducement for the Department to enter into this Agreement and provide the Appropriated Amount.
- b. Grantee shall ensure all representations and warranties provided herein are true, accurate, and complete as of the date of the Effective Date and shall remain so throughout the Term of this Agreement. Grantee is responsible for promptly notifying the Department in writing of any changes or inaccuracies in the representations and warranties contained herein.

B. Grantee hereby represents and warrants the following:

- a. Grantee has taken all necessary steps to attain the legal authority to receive and expend the Project's funds.
- b. Grantee has duly authorized this Agreement, and the person executing it has authority to do so. Once executed by Grantee, this Agreement shall constitute a binding obligation of Grantee, enforceable according to its terms.
- c. Grantee's obligations hereunder do not conflict with any law, ordinance, or resolution applicable to Grantee, Grantee's charter (if applicable), or any judgment or decree to which Grantee is subject.
- d. Grantee has independently confirmed that the Project Description, including, but not limited to, the Appropriated Amount and Reversion Date, is consistent with the underlying appropriation in law.
- e. Grantee's governing body has duly adopted or passed as an official act a resolution, motion, or similar action authorizing the person identified as the official representative of the Grantee to sign and submit Requests for Payment on behalf of Grantee.

- f. Grantee will abide by New Mexico laws regarding conflicts of interest, governmental conduct, and whistleblower protection.
 - i. Grantee agrees explicitly none of its officers or employees or its designees or agents, no member of the governing body, and no other public official of Grantee who exercises any function or responsibility with respect to this Agreement, shall have any interest, direct or indirect, in any contract or subcontract, or the proceeds thereof, for the Project.
 - ii. Further, Grantee will require all of its contractors to incorporate the language set forth in this paragraph prohibiting conflicts of interest in all subcontracts.
- g. No funds have been paid or will be paid, by or on behalf of the Grantee, to any person for influencing or attempting to influence an officer or employee of the State, any agency, or body in connection with the awarding of any Third Party Obligation.
 - i. Grantee will require certifying language prohibiting lobbying to be included in the award documents for all subawards, including subcontracts, loans, and cooperative agreements.

C. Consequences of False or Misleading Representations. If any representation or warranty made by Grantee is found to be false or misleading, the Department shall have the right to exercise any or all of the following remedies:

- a. **Termination of Agreement:** Department may terminate this Agreement immediately upon written notice to the Grantee.
- b. **Repayment of Grant Funds:** Grantee shall repay all Appropriated Amounts disbursed under this Agreement, upon demand by the Department.
- c. **Other Remedies:** Department may pursue any other remedies available at law or in equity.

D. Survival of Representations and Warranties. The representations and warranties made by the Grantee shall survive the Early Termination or expiration of this Agreement.

XII. PROJECT RECORDS

- A. Grantee shall be strictly accountable for receipts and disbursements relating to the Project's funds. The Grantee shall follow generally accepted accounting principles and the State's Model Accounting Practices and, if feasible, maintain a separate bank account or fund with a separate organizational code to ensure separate budgeting and accounting of the funds.
- B. For six (6) years following the Project's completion ("**Record Retention Period**"), Grantee shall maintain all Project-related records, including, but not limited to, all financial records, requests for proposals, invitations to bid, selection and award criteria, contracts and subcontracts, advertisements, minutes of pertinent meetings, as well as records sufficient to fully account for the amount and disposition of the Appropriated Amount from all sources budgeted for the Project, the purpose for which such funds were used, and such other records as the Department may prescribe.
- C. Grantee shall make all Project records available to the Department, the Department's Independent Public Accountant, and the New Mexico State Auditor upon request. With respect to the funds that are the subject of this Agreement, if the State Auditor or the Department finds any funds were improperly expended, Grantee shall be required to reimburse the State all amounts found to be improperly expended.

XIII. IMPROPERLY REIMBURSED FUNDS

If the Department determines part or all of the Appropriation Amount was improperly reimbursed to Grantee, including but not limited to funds reimbursed to Grantee based upon fraud, mismanagement, misrepresentation,

misuse, violation of law by the Grantee, after ten (10) days' notice to Grantee and the opportunity to return such funds to the Department, the Department may offset any funds due to Grantee from the State, until the Appropriation Amount is fully repaid.

XIV. LIABILITY

Neither Party shall be responsible for liability incurred as a result of the other Party's acts or omissions in connection with this Agreement. Any liability incurred in connection with this Agreement is subject to immunities and limitations of the New Mexico Tort Claims Act.

XV. SCOPE OF AGREEMENT

This Agreement constitutes the entire and exclusive agreement between the Parties concerning the subject matter hereof. The Agreement supersedes all prior or contemporaneous agreements, understandings, discussions, communications, and representations, written or verbal.

XVI. REQUIRED NON-APPROPRIATIONS CLAUSE

- A. Grantee acknowledges and agrees to include a "non-appropriations" clause in all contracts between it and other parties that are (i) funded in whole or part by funds made available under this Agreement and (ii) entered into after the effective date of this Agreement that states:
 - a. "The terms of this Agreement are contingent upon sufficient appropriations and authorization being made by the Legislature of the State of New Mexico ("**Legislature**") for the performance of this Agreement.
 - b. If the Legislature does not make sufficient appropriations and authorization, [Grantee's name] may immediately terminate this Agreement by giving Contractor written notice of such termination.
 - c. [Grantee's name]'s decision as to whether sufficient appropriations are available shall be final and accepted by the Contractor. Contractor hereby waives any rights to assert an impairment of contract claim against the [Grantee's name] or the State of New Mexico in the event of immediate or Early Termination of this Agreement by the [Grantee's name] or the State Department of Finance and Administration."

XVII. REQUIRED TERMINATION CLAUSE

- A. Grantee acknowledges and agrees to include the following termination clause in all contracts that are (i) funded in whole or part by funds made available under this Agreement and (ii) entered into after the effective date of this Agreement:
 - a. "This contract is funded in whole or in part by funds made available by the State of New Mexico ("**State**"). Should the State terminate its Agreement with [Grantee's name], [Grantee's name] may terminate this contract immediately by providing Contractor written notice of such termination.
 - b. In the event of termination pursuant to this paragraph, [Grantee's name] only liability to Contractor shall be for goods and services delivered and accepted prior to the termination date."

XVIII. COMPLIANCE WITH UNIFORM FUNDING CRITERIA

- A. Throughout the term of this Agreement, Grantee shall:
 - a. Submit all reports of annual audits and agreed-upon procedures required by § 12-6-3(A)-(B), NMSA 1978 by the due dates established in § 2.2.2 NMAC, reports of which must be a public

record pursuant to § 12-6-5(A), NMSA 1978 within forty-five (45) days of delivery to the State Auditor;

- b. Have a duly adopted budget for the current fiscal year approved by its budgetary oversight agency (if any);
- c. Timely submit all required financial reports to its budgetary oversight agency (if any); and
- d. Use accounting methods and procedures consistent with Generally Accepted Accounting Principles and the State's Model Accounting Principals to expend the Appropriated Amount in accordance with applicable law and account for and safeguard Project funds and assets acquired with Project funds.

B. In the event Grantee fails to comply with the requirements of subparagraph A of this Article XVIII, Department may take one or more of the following actions:

- a. Suspend new or further obligations pursuant to Article VI(A) of this Agreement;
- b. Require the Grantee to develop and implement a written corrective action plan pursuant to Article VI(D) of this Agreement to remedy the non-compliance;
- c. Impose special conditions to address the non-compliance by giving Grantee notice of such special conditions in accordance with Article III of this Agreement;
 - i. The Parties agree that any special conditions imposed to address non-compliance shall be incorporated into this Agreement, through **Exhibit C**, upon notice to Grantee, without need for formal amendment of this Agreement;
 - ii. Special conditions shall be binding and effective on the date that notice is deemed to have been given pursuant to Article III or
- d. Terminate this Agreement pursuant to Article V(A) of this Agreement.

XIX. SEVERANCE TAX AND GENERAL OBLIGATION BONDS

A. Grantee acknowledges and agrees that the underlying appropriation for the Project may originate from the issuance of tax-exempt severance tax bonds or general obligation bonds by the State. Proceeds from such bonds are administered by the New Mexico State Board of Finance ("**SBOF**"), an entity separate and distinct from the Department.

- a. Grantee acknowledges and agrees:
 - i. It is Grantee's responsibility to determine through SBOF what (if any) conditions are currently imposed on the Project;
 - ii. Department's failure to inform Grantee of an SBOF-imposed condition does not affect the validity or enforceability of the condition;
 - iii. The SBOF may in the future impose further or different conditions upon the Project;
 - iv. All SBOF conditions are attached to the Project and Appropriation Amount without the need for formal amendment of this Agreement;
 - v. All applicable SBOF conditions must be satisfied before the SBOF will release to the Department funds subject to the condition(s) and
 - vi. The Department's obligation to reimburse Grantee from the Project is expressly contingent upon the satisfaction of the then-current SBOF conditions.

B. Grantee acknowledges and agrees SBOF may, at its sole and absolute discretion, require reimbursement or remove eligibility for bond proceeds for the Project if the Project doesn't proceed sufficiently.

- a. Grantee must comply with the requirement to encumber five percent (5%) of Project funds within six months of bond issuance as certified by Grantee in the Bond Questionnaire and Certification documents submitted to the SBOF.

- b. Failure to comply may result in the reassignment of the bond proceeds. Upon reassignment of bond proceeds, this Agreement will be suspended until the entity has demonstrated readiness as determined by the SBOF and the Department.
- C. Grantee acknowledges and agrees that this Agreement is subject to the SBOF's Bond Project Disbursements rule, § 2.61.6, NMAC, as may be amended from time to time or re-codified.

XX. GENERAL PROVISIONS

- A. Assignment: Grantee's rights and obligations under this Agreement are personal and may not be transferred or assigned without the prior written consent of the State. Any attempt at assignment or transfer without such consent shall be void. Any assignment or transfer of Grantee's rights and obligations approved by the State shall be subject to the provisions of this Agreement.
- B. Subcontractors: Grantee shall not enter any subgrant or subcontract in connection with its obligations under this Agreement without the prior written approval of the State. Upon request, Grantee shall submit to the Department a copy of each such subgrant or subcontract.
- C. Binding Effect: Except as otherwise provided, all provisions of this Agreement, including the benefits and burdens, shall extend to and be binding upon the Parties' respective successors and assigns.
- D. Authority: Each Party represents and warrants to the other that the execution and delivery of this Agreement and the performance of such Party's obligations have been duly authorized.
- E. Captions and References: The captions and headings in this Agreement are for the convenience of reference only and shall not be used to interpret, define, or limit its provisions. All references in this Agreement to sections (whether spelled out or using the § symbol), subsections, exhibits, or other attachments are references to sections, subsections, exhibits, or other attachments contained herein or incorporated as a part hereof, unless otherwise noted.
- F. Counterparts: This Agreement may be executed in multiple, identical, original counterparts, each of which shall be deemed to be an original, but all of which, taken together, shall constitute the same agreement.
- G. Digital Signatures: If any signatory signs this agreement using a digital signature in accordance with the State Policies regarding the use of digital signatures, then any agreement or consent to use digital signatures within the electronic system through which that signatory signed shall be incorporated into this Agreement by reference.
- H. Modification: Except as otherwise provided in this Agreement, any modification to this Agreement shall only be effective if agreed to in a formal amendment, properly executed and approved in accordance with applicable New Mexico law and State fiscal policies and rules. Modifications permitted under this Agreement, other than Agreement amendments, shall conform to the policies issued by the State.
- I. Statutes, Regulations, Fiscal Rules, and Other Authority: Any reference in this Agreement to a statute, regulation, policy, or other authority shall be interpreted to refer to such authority then current, as may have been changed or amended after the Effective Date of this Agreement.
- J. External Terms and Conditions: Notwithstanding anything to the contrary herein, the State shall not be subject to any provision included in any terms, conditions, or agreements appearing on Grantee's or a subcontractor's website or any provision incorporated into any click-through or online agreements related to the Work unless that provision is specifically referenced in this Agreement.
- K. Severability: The invalidity or unenforceability of any provision of this Agreement shall not affect the validity or enforceability of any other provision of this Agreement, which shall remain in full force and

effect, provided that the Parties can continue to perform their obligations under this Agreement in accordance with its intent.

- L. **Survival of Certain Agreement Terms:** Any provision of this Agreement that imposes an obligation on a Party after the termination or expiration of this Agreement shall survive the termination or expiration of this Agreement and shall be enforceable by the other Party.
- M. **Third Party Beneficiaries:** Except for the Parties' respective successors and assigns described in this Agreement, it does not and is not intended to confer any rights or remedies upon any person or entity other than the Parties. Enforcement of this Agreement and all rights and obligations hereunder are reserved solely to the Parties. Any services or benefits that third parties receive as a result of this Agreement are incidental to this Agreement and do not create any rights for such third parties.
- N. **Waiver:** A Party's failure or delay in exercising any right, power, or privilege under this Agreement, whether explicit or by lack of enforcement, shall not operate as a waiver, nor shall any single or partial exercise of any right, power, or privilege preclude any other or further exercise of such right, power, or privilege.
- O. **Standard and Manner of Performance:** Grantee shall perform its obligations under this Agreement in accordance with the highest standards of care, skill, and diligence in Grantee's industry, trade, or profession.
- P. **Licenses, Permits, and Other Authorizations:** Grantee shall secure, prior to the Effective Date, and maintain at all times during the term of this Agreement, at its sole expense, all licenses, certifications, permits, and other authorizations required to perform its obligations under this Agreement and shall ensure that all employees, agents, and subcontractors secure and maintain at all times during the term of their employment, agency or subcontractor, all license, certifications, permits and other authorizations required to perform their obligations in relation to this Agreement.
- Q. **Publicity:** Any Publicity regarding the subject matter of this Agreement may not be released without prior written approval from the Department. For purposes of this agreement, "**Publicity**" means notices, informational pamphlets, press releases, email responses, research, reports, signs, and similar public notices prepared by or for the Grantee or jointly with others.
 - a. Grantee shall obtain written approval prior to issuing any press release or making any public announcement regarding this agreement. Grantee agrees to obtain approval of the Department in advance with respect to all Public Relations, all communications with media, or all communications with any other member of the public with respect to this agreement, except to acknowledge that an agreement does exist.
 - b. For purposes of this agreement, "Public Relations" includes community relations and means those activities dedicated to maintaining the Department's image or maintaining or promoting understanding and favorable relations with the community or public at large or any segment of the public.
 - c. Violations of either Article XX (Q)(a) or (b) shall constitute a material Breach of Agreement.
- R. **Data Sharing:** The State intends to secure and collate specific data generated by Grantee under this Agreement to use in support of the State's organizational, policy-making, and management of public resource functions. State, in accordance with **Exhibit E**, attached hereto and incorporated herein by reference, reserves the right to require Grantee and/or its subcontractors to provide specific data relevant to the above-listed functions. Data provided by Grantee may be incorporated into existing or future

developed State integrated analysis tools or databases, including but not limited to geographic information system (GIS) networks and databases accessible by the public. Dissemination of data collected may include historical data and projections based on such historical data.

- a. To the extent any data transferred as part of this Agreement is legally determined to be the property of Subrecipient or its subcontractors, Subrecipient and/or its subcontractors grants State a nonexclusive, fully paid-up right and license to reproduce, use, distribute, do derivative works based on, and archive data transferred as part of this Agreement.

S. Venue and Choice of Law: This Agreement shall be governed by and construed in accordance with the laws of the State of New Mexico, without regard to any conflict of law provisions. Any legal suit, action, or proceeding arising out of or related to this Agreement shall be instituted exclusively in the district courts located in Santa Fe, New Mexico. The Parties hereby irrevocably submit to the exclusive jurisdiction and venue of such courts in any such suit, action, or proceeding. The Parties waive any objection to the laying of the venue of any such suit, action, or proceeding in the district courts of Santa Fe, New Mexico, and irrevocably waive and agree not to plead or claim in any such court that any such suit, action, or proceeding brought in any such court has been brought in an inconvenient forum.

[SIGNATURE PAGE AND EXHIBITS FOLLOW]
[THIS SPACE LEFT BLANK INTENTIONALLY]

IN WITNESS WHEREOF, the parties have duly executed this Agreement as of the Department's date of execution.

APPROVED BY GRANTEE:

Entity Name

Official with Authority to Bind Grantee:

Signature

(Print Name)

(Title)

Date

Fiscal Officer or Chief Financial Officer: (OPTIONAL)

Signature

(Print Name)

(Title)

Date

Legal Counsel: (OPTIONAL)

Signature

(Print Name)

(Title)

Date

APPROVED BY DEPARTMENT:

New Mexico Environment Department

Dennis Romero, P.E., Bureau Chief, NMED Construction Programs Bureau
Signed pursuant to the June 23, 2025, Secretary of Environment Delegation Order

EXHIBIT A

Request for Payment Form and Certification

Rev. July 2025	NEW MEXICO ENVIRONMENT DEPARTMENT CONSTRUCTION PROGRAMS BUREAU									
	NMED DISBURSEMENT REQUEST SPECIAL APPROPRIATIONS PROGRAM (SAP)									
A. NAME OF ENTITY			C. DISBURSEMENT REQUEST NUMBER							
B. PROJECT NUMBER			D. GRANT AMOUNT							
	PROJECT BUDGET		PREVIOUS EXPENDITURES		CURRENT EXPENDITURES		CUMULATIVE		FUNDS REMAINING	
	NMED PROGRAM	OTHER FUNDS	NMED PROGRAM	OTHER FUNDS	NMED PROGRAM	OTHER FUNDS	NMED PROGRAM	OTHER FUNDS	NMED PROGRAM	OTHER FUNDS
Engineer Fees										
<i>Other Professional</i>										
Service Fees										
Inspection Fees										
Property Acquisition										
Construction Cost										
Planning Cost										
Equipment										
Other Costs (specify)										
Contingencies										
TOTAL										
<p>Article IX.A. (iii). By checking this box you are stating that payment has NOT been paid to the vendors associated with this request. Upon receipt of payment from NMED, certification of payment will be sent within 10 days from the date of receiving reimbursement.</p> <p>Certification: I hereby certify that all conditions and requirements for Payments outlined in the Agreement have been met, including but not limited to: a.Submission and approval of a Project Budget as per Article IV, Section A of the Agreement. b.Compliance with the Project Budget and expenditure of funds in accordance with the State Procurement Code and the State's Model Accounting Practices. c.Submission of supporting documentation as required by the Agreement. d.Maintenance of all necessary records and documentation as stipulated in the Agreement.</p> <p>Certification: I attest that the information provided is correct; expenditures are properly documented and valid or actual receipts, and that the activity fully complies with Article IX, Sec. 14 of the New Mexico Constitution, known as the "anti-donation" clause.</p> <p>Certification: I hereby certify that all representations and warranties made in the Agreement remain true, accurate, and complete as of the date of this request, and will continue to be so throughout the term of the Agreement. I acknowledge that these representations and warranties are a material inducement for the Department to approve this pay request.</p> <p>Reporting Certification: I hereby certify to the best of my knowledge and belief, that the database reporting is up to date; to include the accuracy of the expenditures and grant balance, project status, project phase, achievements and milestones, and in compliance with Article VIII of the Capital Outlay Grant Agreement.</p>										
Signature of Official Representative:			Typed or Printed Name:			Phone:		Date:		

EXHIBIT B

**NOTICE OF OBLIGATION TO REIMBURSE GRANTEE
EXHIBIT B**

Notice of Obligation to Reimburse Grantee # _____

DATE: _____

TO: Department Representative: _____, Grant Manager

FROM: Grantee Entity: _____
Grantee Official Representative: _____

SUBJECT: Notice of Obligation to Reimburse Grantee
Grant Number: _____
Grant Termination Date: _____

As the designated representative of the Department for Grant Agreement number _____ entered into between Grantee and the Department, I certify that the Grantee has submitted to the Department the following third party obligation executed, in writing, by the third party's authorized representative:

Vendor or Contractor: _____

Third Party Obligation Amount: _____

Vendor or Contractor: _____

Third Party Obligation Amount: _____

I certify that the State is issuing this Notice of Obligation to Reimburse Grantee for permissible purposes within the scope of the project description, subject to all the terms and conditions of the above referenced Grant Agreement.

Grant Amount (Minus AIPP if applicable): _____

The Amount of this Notice of Obligation: _____

The Total Amount of all Previously Issued Notices of Obligation: _____

The Total Amount of all Notices of Obligation to Date: \$ 0.00

Note: Contract amounts may exceed the total grant amount, but the invoices paid by the grant will not exceed the grant amount.

Department Rep. Approver: _____

Title: Grant Manager

Signature: _____

Date: _____

¹ Administrative and/or Indirect Cost – generally, the legislation authorizing the issuance of bonds prohibits the use of its proceeds for indirect expenses (e.g. penalty fees or damages other than pay for work performed, attorney fees, and administrative fees). Such use of bond proceeds shall not be allowed unless specifically authorized by statute.

EXHIBIT E

Data Sharing Provisions

Data Sharing Provisions for New Mexico Capital Outlay Agreements

I. Introduction:

This Data Sharing Provisions Exhibit (“Exhibit”) is incorporated into the New Mexico Capital Outlay Agreements (“Agreements”) between the State of New Mexico (“State”) and [Insert Partner Name] (“Partner”). This Exhibit outlines the terms and conditions under which data will be shared between the Parties to ensure compliance with New Mexico state laws and regulations, focusing on data privacy, security, and compliance.

II. Definitions:

- a. **Authorized User:** An employee, agent, assign, representative, independent contractor, or other person or entity authorized by Partner or State to access, use, or disclose information through this exhibit.
- b. **Confidential Information:** All data or information shared in confidence, with the expectation that it will not be disclosed in an identifiable form. This includes data that is exempt from public disclosure under the New Mexico Inspection of Public Records Act (§ 14-2-1 et seq. NMSA 1978) or other relevant laws.
- c. **Data Storage:** Electronic media that hold recorded information.
- d. **Data Transmission:** The process of moving information over a network from its source to one or more destinations.
- e. **Direct Identifier:** Records or data containing personal identifiers such as names, addresses, and social security numbers.
- f. **Disclosure:** Permission to access, release, transfer, or otherwise communicate confidential information by any means to any third party, except as authorized by the Party that controls the record.
- g. **Encryption** involves using algorithms to encode data, rendering it unreadable without a specific key. It may be necessary during data transmission and/or storage.
- h. **Information:** Any data, figures, statistics, or other facts provided or learned about someone or something, including Confidential Information, that may be legally transmitted under this Exhibit.
- i. **Limited Dataset:** A data file that omits Direct Identifiers.
- j. **Protected Personally Identifiable Information:** Sensitive personal details such as social security numbers and financial account numbers, with specific exclusions as outlined in the Agreements.

III. Purpose:

The purpose of this exhibit is to promote transparency, facilitate information sharing between the parties, support better policy and decision-making, and enhance public services through collaborative data analysis from various sources.

IV. Use of Information:

- a. Use of Information obtained or created under this exhibit shall be strictly limited to the purposes stated herein and in the agreements. The parties agree not to sell Information to third parties or use it for commercial, solicitation, or political purposes.
- b. Each Party shall serve as the custodian of the Information and comply with all conditions for its use, including security measures to prevent unauthorized access.
- c. The Parties shall follow all relevant federal and state laws and regulations governing the use of such Information.

V. Safeguarding Information:

- a. Confidentiality: Access to Confidential Information shall be limited to the minimum necessary to accomplish the purposes of this Exhibit. Authorized Users must adhere to the confidentiality requirements.
- b. Security: Security practices shall comply with the requirements of the New Mexico Department of Information Technology Act and related regulations. The Parties agree to notify each other within three business days of any suspected or actual security breach.
- c. Information Storage and Transmission: Data Storage and Transmission shall take place on an encrypted server with appropriate security controls.

VI. Re-Disclosure of Information:

The Parties agree not to disclose Information except as required by law or with prior written approval of the other Party. If there is a public records request, the Party receiving it shall notify the other Party within three business days.

VII. Ownership of Information:

Legal title to Information shall remain with the provider. The Partner grants the State a royalty-free, non-exclusive, non-transferable license to use the Information in furtherance of the purposes outlined in this Exhibit.

Capital Appropriations Certification Document

Article IX. A. (ii) and (iii)

(City of Santa Fe SAP 25-J2459-GF)

Payment Request No _____

I certify that payment to all vendors on the above referenced payment request were paid no more than ten (10) days after receiving reimbursement from NMED.

Official Representative, Signed Name, Printed Name, Date

ATTACHMENT A

**NEW MEXICO ENVIRONMENT DEPARTMENT
CONSTRUCTION PROGRAMS BUREAU**

PROJECT BUDGET

GRANTEE: City of Santa Fe

PROJECT NO: SAP 25-J2459-GF

Please provide a comprehensive procurement plan and expenditure plan, detailing a Project timeline with milestones, required procurements, and identifying expected expenditures per milestone, referred to collectively as the "Project Budget." While it can be difficult to estimate costs and timelines, setting a plan for these can help keep realistic expectations and goals to keep a project moving forward to achieve the project scope and objectives. Contact your NMED-CPB Project Manager with questions.

1) Expenditure Plan. Indicate what expenses funding will be used.

Detailed Expenditure Plan		
USES OF FUNDS	NMED PROGRAM	OTHER FUNDS
Engineer Fees		
Other Professional		
Service Fees		
Inspection Fees		
Property Acquisition		
Construction Cost		
Planning Cost		
Equipment		
Other Costs (specify)		
Contingencies		
TOTAL	\$ -	\$ -

- 2) **Procurement Plan.** Describe how engineering or professional services, construction contractors, equipment, or other goods or services will be procured.

Chief Procurement Officer

All Public Bodies are required by 13-1-95.2 NMSA 1978 to have a Chief Procurement Officer to conduct all procurement activities.

Who is your Chief Procurement Officer (CPO)? _____

Describe how you will secure CPO services, if you currently do not have a CPO. _____

Professional Services

Have engineering or professional services already been procured and contracted? _____

If not, describe how you will procure engineering or professional services _____

Reminders:

- COSTS ABOVE \$60,000, require solicitation of services via a Request for Proposal (RFP).
- COSTS BELOW \$60,000 must adhere to 13-1-125 NMSA 1978 and procurements cannot be artificially divided into smaller units to circumvent legal requirements, such as formal solicitation.
- MULTI-TERM CONTRACTS can be renewed for up to four years 13-1-150 NMSA 1978. Monitor the remaining time on your contracts and plan for renewal in advance.

Construction

Contractors must be hired using a public bidding process for any project over \$60,000 (13-1-125 NMSA 1978) and procurements cannot be artificially divided into smaller units to circumvent legal requirements, such as formal solicitation.

Equipment Purchase

Equipment purchase must follow proper procurement code. Please see Chapter 13 Public Purchase and Property NMSA 1978.

- 3) **Project Timeline.** Setting a timeline can help keep a project on track to meet required expenditure deadlines. *(An example schedule is provided below.)*

Project Timeline:

OVERALL – MILESTONES		EXPECTED EXPENDITURE PER MILESTONE
ESTIMATED START DATE		
5% FUNDS OBLIGATED*		
ESTIMATED END DATE		
DETAILED – PHASES		
TOTAL		\$

***Disclaimer:** You have accepted grant funds on the condition that 5% of these funds are to be obligated in a Notice of Obligation within 6 months of bond issuance in accordance with XIX.B.(STB’s only) and at least 10% within one (1) year in accordance with IX.B (all projects).

You can obligate funds by entering into a contract with an engineer or contractor. State Procurement Code must be followed for the purchase of all goods and services.

Your NMED-CPB project manager will be happy to help you navigate these requirements, so that your grant money can be spent, and your project successfully completed.

Example Timeline:

OVERALL – MILESTONES		EXPECTED EXPENDITURE PER MILESTONE
ESTIMATED START DATE	Month 0	
5% FUNDS OBLIGATED*	+ 6 months from start date = Month 6	\$100,000
ESTIMATED END DATE	Use detailed schedule below. 2.5- 3 years	
DETAILED – PHASES		
HIRE AN ENGINEER	4 months	
PLANNING DOCUMENT	6 months	\$25,000
DESIGN, PERMIT	9 months	\$60,000
ADVERTISE FOR BID, AWARD PROJECT	6 months (allow for rebid)	
CONSTRUCTION AND ENGINEERING CONSTRUCTION PHASE SERVICES (START TO FINISH)	Varies widely. 6 months to a year, or more.	\$750,000 and \$15,000
CLOSEOUT CONSTRUCTION/ FUNDS	1 month at end of construction schedule.	
TOTAL		\$850,000

- 4) **Additional Information.** Please use this space below to provide any additional details about your project you would like to share to show your project plan and readiness.

Grantee Signatory Authority

Print Name

ATTACHMENT B
TECHNICAL REQUIREMENTS
NEW MEXICO ENVIRONMENT DEPARTMENT
CAPITAL OUTLAY

ARTICLE 1 REVIEW

Upon execution of the grant agreement, the Grantee will follow the procedures listed below unless waived in writing by the New Mexico Environment Department (NMED) (payment may be withheld if any of these procedures are not followed by the Grantee).

- A. The Grantee must submit copies to NMED of all unexecuted contracts or quotes the Grantee intends to enter in that are related to the project for the creation of a notice of obligation. Only approved eligible expenditures incurred after the effective date of the Grant Agreement shall be reimbursed or paid from these funds.
- B. If grant funds are used for construction, a site certificate must be submitted prior to project bid advertisement that certifies all necessary easements, rights-of-way, and/or property upon or through which the project is being constructed have been obtained. The Site Certificate must be signed by an attorney, engineer, surveyor, or title abstractor.
- C. If grant funds are used for meter installation, the Grantee must follow the NMED Guidelines for Meter Upgrade Projects. Meters must be installed before payment can be made. Request a copy of the Guidelines from your NMED Project Manager.
- D. If grant funds are used for construction, the Grantee will submit notice of the award and a copy of the executed construction contract documents.
- E. The Grantee will provide a full-time construction inspector during construction of the project unless NMED determines that part time inspection is adequate for the project. This must be requested and approved by NMED prior to the start of construction.
- F. All daily construction inspection reports shall be made available to the NMED upon request.
- G. Notwithstanding the inspections performed by the Grantee and its engineer, NMED will have the right to examine all installations comprising the project, including materials delivered and stored on-site for use on the project. Such examinations will not be considered an inspection for compliance with contract plans but will be a general NMED review as described in Article 2 below.

ARTICLE 2 NMED OVERSIGHT

NMED oversight is only for purposes of compliance with applicable state grant requirements, procedures, statutes, and regulations. NMED approval will not be interpreted as a warranty or guarantee of any kind. Responsibility for the design of the project will lie solely with the engineer of record. All defects and their correction will be the responsibility of the Grantee and its contractors and engineers or consultants. Any questions raised by NMED during its inspections and reviews shall be resolved exclusively by the Grantee. The Grantee and its contractors and engineers or consultants will remain responsible for the completion and success of the project. No action by NMED shall relieve the owner, engineer, or contractor of legal responsibilities for the overall integrity of the project, adequacy of the design, safety, or compliance with all applicable regulations.

ARTICLE 3 CLOSEOUT

- A. The project will not be considered complete until the work as defined in this agreement has been fully performed, and finally and unconditionally accepted by the Grantee and the engineer of record.

- B. If the grant funds are used for purchase of equipment, final payment will be made after receipt of the equipment and equipment title, if applicable. Appraisal reports are required for the purchase of used equipment.
- C. If the grant funds are used for construction, final payment will be made after the following items, unless waived by NMED, have been provided to NMED, and have been reviewed and approved by NMED:
- i. A certificate of substantial completion including punch list items.
 - ii. A final certified construction pay request prepared by the Grantee's project engineer and approved by the Grantee.
 - iii. A written consent of the surety, if any, to final payment.
 - iv. Complete and legally effective releases or waivers (satisfactory to the Grantee) of all liens arising out of the contract documents and the labor services performed and the materials and equipment furnished there under. In lieu thereof and as approved by the Grantee, contractor(s) may furnish receipts or releases in full; an affidavit of contractor that the releases and receipts include labor, services, materials, and equipment for which a lien could be filed and that all payrolls, material and equipment bills, and other indebtedness connected with the work for which the Grantee or its property might in any way be responsible, have been paid or otherwise satisfied.
 - v. Certification letter by the Grantee and contractor that the Labor Standards Contract Provisions have been met.
 - vi. Certification letter of project acceptance by the Grantee and the Grantee's project engineer stating that work has been satisfactorily completed and the construction contractor has fulfilled all of the obligations required under the contract documents with the Grantee, or if payment and materials performance bonds are "called", an acceptance close-out settlement to the Grantee and contractors will be submitted to NMED.
 - vii. Certification letter from the Grantee confirming receipt and acceptance of the record drawings and operation and maintenance manuals.

A RESOLUTION AUTHORIZING PROJECT SAP 25-J2459-GF AS DESCRIBED IN ATTACHMENT A, AND THE ASSIGNMENT OF AUTHORIZED OFFICER(S) AND AGENT(S)

Resolution Number

Whereas, the **Board of Directors / Council / Commission** of **Community / Utility** of **County Name** County of the State of New Mexico shall enter into a Grant Agreement with the State of New Mexico Environment Department, and

Whereas, the Agreement is identified as **Project Number SAP** SAP 25-J2459-GF

NOW THEREFORE, BE IT RESOLVED by the named applicant that:

(Name), Mayor/ Chairperson / Director / Officer, or successor is authorized to sign the Grant Agreement for this project, and

(Authorized Office Name), (Authorized Officer Title), (may have more than one) or successor is the OFFICAL REPRESENTATIVE(S) who is authorized to sign all other documents necessary to fulfill the Grant Agreement and the requirements (Project Description, Disbursements and to act as the project contact, and

(Designated Agent or Employee Name), (Title), or successor is the DFA Database contact who is designated to update the database quarterly per Article VIII. A. of the Intergovernmental Grant Agreement.

(Designated Agen or Employee Name, (Title), (may have more than one) or successors is the CONTACT who is designated to receive Notice of Obligations (NOO'S).

PASSED, APPROVED, AND ADOPTED: _____.

Name, Mayor / Chairperson / Director / Officer, Title, Community / Utility

(Signature)

Date

(SEAL)

ATTEST:

(Municipal Clerk)

Name of Grantee: City of Santa Fe Project Number: SAP 25-J2459-GF

Current Authorized Signatures (submit with Signature Resolution, update when necessary)

Authorized to Sign Agreement			
Name		Name	
Title		Title	
Signature		Signature	
Address		Address	
Email		Email	
Phone		Phone	
Official Representatives authorized to sign Disbursement Requests and all other documents.			
Name		Name	
Title		Title	
Signature		Signature	
Address		Address	
Email		Email	
Phone		Phone	
Alternate Official Representative, to sign Disbursement Requests and all other documents and act as the Point of Contact.			
Name		Name	
Title		Title	
Signature		Signature	
Address		Address	
Email		Email	
Phone		Phone	
Designated Agent or Employee that will make DFA database updates			
Name		Name	
Title		Title	
Signature		Signature	
Address		Address	
Email		Email	
Phone		Phone	
Notice of Obligations			
Name		Name	
Title		Title	
Signature	No Signature Required	Signature	No Signature Required
Address		Address	
Email		Email	
Phone		Phone	

FISCAL IMPACT REPORT

General Information:

(Check) Bill: _____ Resolution: X

Short Title(s): Authorizing Representatives and Agents for NMED Grant Agreement SAP 25-J2459-GF

Sponsor(s): Councilor Amanda Chavez

Reviewing Department(s): Public Works Department

Staff Completing FIR: Carol Swenson Date: 01/22/2026 Phone: (505) 469-2943

Reviewed by City Attorney: *Marcos Martinez*
 Marcos Martinez (Jan 23, 2026 08:26:27 MST) Date: _____

Reviewed by Finance Director: *Andrea Phillips*
 ANDREA PHILLIPS (Jan 23, 2026 14:28:32 MST) Date: _____

Summary:

This Resolution designates authorized representatives and agents for an agreement with New Mexico Environment Department (NMED) regarding Capital Appropriation Project SAP 25-J2459-GF (“Agreement”). The Agreement makes available one hundred thousand dollars (\$100,000), appropriated by the New Mexico State Legislature for a project to plan, design, and construct a wastewater treatment facility in Santa Fe in Santa Fe County.

Departments Affected:

Public Works Department and Public Utilities Department.

Consequences of Not Enacting Legislation:

If this legislation is not adopted, The City of Santa Fe (“City”) will not satisfy Article XI.B.(e) of the Agreement, which requires the Governing Body to adopt a resolution, motion, or similar action authorizing the person identified as the official representative of the City to sign the Agreement and to sign and submit Requests for Payment. Additionally, without the adoption of this Resolution the City would not receive NMED funding in the amount of one hundred thousand dollars (\$100,000).

Conflict, Duplication, Companionship, or Relationship to Other Legislation:

The Governing Body will approve the agreement through a separate action.

Performance and Administrative Implications:

Public Utilities Department may pursue acquiring land for and plan, design, construct, purchase, repair, permit and improve a regional wastewater treatment plant for the City of Santa Fe in association with this Agreement. Public Utilities Department and Finance Department staff will also administer the grant.

Fiscal Implications:

None.

Fiscal Impact

 X Check here if no fiscal impact

Expenditures

Expenditure Type	FYE 2026	FYE 2027	FYE 2028	Require BAR (Y/N)	Recurring (R) or Non-recurring (NR)	Fund	3-Year Total Cost
<u>Personnel and Benefits*</u>	\$ _____	\$ _____	\$ _____	_____	_____	_____	
<u>Capital Outlay</u>	\$ _____	\$ _____	\$ _____	_____	_____	_____	
<u>Contractual/</u>	\$ _____	\$ _____	\$ _____		_____	_____	
<u>Professional Services</u>							
<u>Operating</u>	\$ _____	\$ _____	\$ _____		_____	_____	\$ _____
<u>Total:</u>	\$ _____	\$ _____	\$ _____				\$ _____

Expenditure Narrative:

Revenue

Revenue Type	FYE 2026	FYE 2027	FYE 2028	Recurring (R) or Non-recurring (NR)	Fund
General Fund	\$ _____	\$ _____	\$ _____	_____	_____
Special Revenue	\$ _____	\$ _____	\$ _____	_____	_____
CIP	\$ _____	\$ _____	\$ _____	_____	_____
Enterprise	\$ _____	\$ _____	\$ _____	_____	_____
Internal Service	\$ _____	\$ _____	\$ _____	_____	_____
Trust and Agency	\$ _____	\$ _____	\$ _____	_____	_____
Federal	\$ _____	\$ _____	\$ _____	_____	_____
Other	\$ _____	\$ _____	\$ _____	_____	_____
Total	\$ _____	\$ _____	\$ _____		

Revenue Narrative:

Signature:

Email:

Signature:

Email: