



The Purchasing Memo

Date: January 6, 2026

To: Governing Body
Finance Committee
Public Utilities/ Public Works

From: Martin Valdez, ESD Fleet Manager 

Via: Jesse Roach, Interim Public Utilities Director 
Debora Trujillo, Environmental Services Division Director 

Subject: Purchase of Two (2) Roll-Off Collection Vehicles

Vendor Name: Rush Truck Centers of New Mexico, Inc.

Munis Vendor Number: 2011

ITEM AND ISSUE:

The Public Utilities Department (Environmental Services Division) requests review and approval for the purchase of **Two (2) Roll-Off Collections Vehicles** from **Rush Truck Centers of New Mexico, Inc.** The total purchase amount is **\$548,338.00**. The procurement will be made through the National Purchasing Cooperative (BuyBoard Contract #723-23) which expires November 30, 2026, to ensure competitive pricing and compliance with cooperative purchasing requirements.

BACKGROUND AND SUMMARY:

The Environmental Services División utilizes roll-off collection vehicles for the transport and disposal of large waste containers from commercial and municipal customers. Two (2) of our existing units in the fleet have reached the end of their useful service life and are considered non-viable due to age, high maintenance costs, and frequent mechanical failures.

Replacing these aged vehicles with new roll-off collection units will improve operational reliability, reduce maintenance expenses, and support the department's ability to maintain efficient and uninterrupted solid waste collection services.

PRIOR APPROVALS AND SUPPORTING INFORMATION:

FUNDING SOURCE:

Fund Name/Number: ESD Enterprise Fund / Fund 510

Munis Org Name/Number: ESD Commercial Collections / 5100332

Munis Object Name/Number: Vehicles > 1.5 / 571000

Budget Officer / Designee: Andy Hopkins Date: 01/08/2026

Budget Officer Comment/Exceptions: _____

PROCUREMENT METHOD:

The procurement method used was:

National Purchasing Cooperative Contract #723-23, Exp November 30, 2026

Chief Procurement Officer (CPO) / Designee: [Signature] Date: 01/09/2026

CPO Comment/Exceptions: 13-1-135 - BuyBoard Coop - Please send this to Assests so Rebecca can track

ASSOCIATED APPROVALS:

IT Components included? Yes | No

Approval: _____ Title: _____ Date: _____

Comment/Exceptions: _____

Vehicles included? Yes | No

Approval: _____ Title: _____ Date: _____

Comment/Exceptions: approved via email as shown below!

Construction to City Facilities, Furniture, and/or Fixtures included? Yes | No

Approval: _____ Title: _____ Date: _____

Comment/Exceptions: _____

Is this an externally funded purchase? Yes | No

If yes, what is the issuing agency: _____

Approval: _____ Title: _____ Date: _____

Comment/Exceptions: _____

Is this a Capital Asset or Project? Yes | No

Project Ledger Number: _____

Approval: _____ Title: _____ Date: _____

Comment/Exceptions: _____

ATTACHMENTS:

- Vendor's Quote
- Vendor's Contract Info Summary
- National Purchasing Cooperative Contract Award Letter
- Contract #723-23 Pricing
- Fleet Maintenance Manager's Recusal Memo



Rush Truck Centers of New Mexico, Inc.
 6521 Hanover Road NW
 Albuquerque, NM 87121
 505-875-3410

Customer Proposal Letter

City of Santa Fe Solid Waste
 2651 SIRINGO ROAD
 SANTA FE, NM 87505

BuyBoard Contract # 723-23

Thank you for trusting us with your business. Please review the proposal below, and if you approve, sign and return to us at your convenience. We look forward to working with you and will continue to do our best to earn your trust now and in the future.

VEHICLE INFORMATION

Year 2026 Make Peterbilt Model 567 Stock # TBD Serial # TBD

Quantity	<u>2</u>	Total
Truck Price per Unit	<u>\$ 273,819.00</u>	<u>\$ 547,638.00</u>
F.E.T. (Factory & Dealer Paid)	<u>\$ 0.00</u>	
Net Sales Price	<u>\$ 273,819.00</u>	<u>\$ 547,638.00</u>
Optional Extended Warranty(ies)		
State Sales Tax		
Documentary Fee	<u>\$ 350.00</u>	<u>\$ 700.00</u>
Total Sales Price	<u>\$ 274,169.00</u>	<u>\$ 548,338.00</u>
Trade Allowance (see DISCLAIMER Below)		
Deposit / Down Payment		
Unpaid Balance Due on Delivery	<u>\$ 274,169.00</u>	<u>\$ 548,338.00</u>

Sales Representative	Signature _____	Carlos Arreola	Printed Name _____	Date _____
Purchaser	Signature _____		Printed Name / Title _____	Date _____
Accepted by Sales Manager or General Manager	Signature _____		Printed Name _____	Date _____

Quote good until 2/6/2026 Note: The above Customer Proposal is a quotation only. Sale terms subject to approval of Sales Manager of Dealer.

DISCLAIMER: Any order based on this Proposal is subject to Customer executing Dealer's standard form Retail Sales Order and other required documents incorporating the above terms. Any documentary fees, FET, state tax, title, registration and license fees subject to adjustment and change. This Proposal is based upon Dealer's current and expected inventory, which is subject to change. Dealer is not obligated to retain any specific vehicles in stock, nor maintain any specific inventory levels. Dealer shall not be obligated to fulfill Proposal in event quoted vehicle(s) is not in stock or available within requested delivery schedule. **Manufacturer has reserved the right to change the price to Dealer of any vehicle not currently in Dealer's stock, without notice to Dealer. If a vehicle identified in this Proposal is not currently in Rush's stock at the time an order is placed by the Customer, Dealer reserves the right to change the vehicle price at any time to reflect any price increases imposed by the Manufacturer.** Dealer shall not be liable for any delay in providing or inability to provide Quoted Vehicle(s). Above listed Trade Value based upon current appraisal of Trade Vehicle(s). Dealer may adjust Trade Value of Trade Vehicle(s) to reflect changes in condition and/or mileage of Trade Vehicle(s) between date of current appraisal and acceptance of the Trade Vehicle by Customer.

(1) Includes subscription period for # of specified months. (2) Customer's use of RushCare Service is governed by the RushCare User Agreement located at <https://www.rushtruckcenters.com/rushcare-user-agreement>. (3) Customer's use of Telematics Services is governed by separate 3rd party license terms and Rush is not liable for the Telematic Service. (4) Gap Coverage is provided and administered by an independent 3rd party provider under a separate contract directly between Customer and the 3rd party provider.



501 Bernard Ave.
 Belen, NM 87002
 505-999-8726 or
 505-864-1010

Quote

Date	Quote #
1/06/2026	15104307

Name / Address
Rush Truck Center - Peterbilt Attn: Carlos Arreola

Contract / PO#

Valid For:

Item	Description	Qty	U/M	Cost	Total
Custom Fabricat...	SPARTAN ROLL OFF UNIT - MODEL SRO-60TK-OR (Tare Weight 6,800 lbs) <ul style="list-style-type: none"> • Hoist is 22' in length • Main Frame: 4" x 8" rectangular steel tubing, 1/2" wall thickness, 34.5" width • Sub Frame: 3" x 2" rectangular steel tubing 3/16" wall thickness • 4 per side, 4"OD x 3.5"L x 1.25" wall thick, 3.5" from top of rails, pins 2.5" OD with zerk fittings, extra pair of rollers • (2) - 6" bore x 4" chrome tube cylinders. 60,000 lb. combined rated lift capacity • Electric ('hot shift') for automatic transmission with P51, 28 - 32 GPM pump • Steel cable 7/8" x 85'(single cylinder) with 1" D Ring • Single cylinder reeving system, 7" bore x 4" x 90" Stroke chrome rod cylinder, center mounted • 40-gallon oil reservoir includes Thru-wall Sump Strainer and 10 Micron return oil filter • Stainless steel quarter fenders, standard • Full fenders, polypropylene composites, includes steel brackets • Air console with 2 ergonomic levers and air switch PTO controls • 18" x 36" heavy duty 10-gauge steel tool box with rear tarp storage & Lockable T handle • Maintenance-free manually collapsable heavy duty vehicle underride protection • Manual combo winches with safety yellow straps for container securement, both sides • 7" Diameter Quick Change Rear Roller • 2 adjustable stops for rail frames, stops holder brackets • Modern LED lighting conforms to safety standards 	1		56,500.00	56,500.00
Total					56,500.00



501 Bernard Ave.
 Belen, NM 87002
 505-999-8726 or
 505-864-1010

Quote

Date	Quote #
1/06/2026	15104307

Name / Address
Rush Truck Center - Peterbilt Attn: Carlos Arreola

Contract / PO#

Valid For:

Item	Description	Qty	U/M	Cost	Total
	<ul style="list-style-type: none"> • Automatic rack and pinion tarping system, includes control valves and levers on driver side • Labor & Installation 				
			Total		56,500.00



SPARTAN
TRUCK COMPANY, INC.



SRO 60

STANDARD SPARTAN FEATURES

-  **60,000 LB CAPACITY**
-  **HIGH SPEED SINGLE CYLINDER REEVING SYSTEM**
-  **MODULAR DESIGN & STANDARDIZED PARTS**
-  **LIGHTWEIGHT DESIGN**
-  **HIGH STRENGTH DURABLE COMPONENTS**
-  **EASIER TO SERVICE BY DESIGN**
-  **QUICK LEADTIMES**

 (818) 899-1111

 (818) 897-4366

 info@spartantruck.com

 Spartan Truck Company | 12266 Branford Street |
Sun Valley, CA 91352



For over 40 years, Spartan Truck Company has been the market leader in manufacturing waste equipment on the west coast. We are proud of our quick lead times, high quality components, & extremely durable Roll-Off systems, trailers and waste bodies.



Standard Specifications

Capacity	60,000 lbs
Rail type	Outside, Universal or In/Out
Cable	3/4" x 77'
Cable Strength	66,800 lbs
Hoist Cylinders	6" Bore, 4" Rod x 74" Stroke
Reeving Cylinder	7" Bore, 4" Rod x 90" Stroke
Outside Control Valve	Commercial VA35
Inside Control Valve	Air Operated Dual Levers
Operating Pressure	1800 PSI
Hydraulic Tank	40G with Sight & Temp gauge
Filtration	Suction Strainer & 10 Micron in tank return filter
PTO	Muncie Air Shift or Hot Shift
Pump	Muncie Direct Mount P51
Sheaves	10" with bronze bushings
Container Size	16' - 24'
Dump Angle	44 - 50 Degrees
Body Weight	6,200 lbs Approx
Frame Rails	4" x 10" x 3/8" Rectangular Tubing ASTM A500
Outside Frame	34 1/2" or 35 1/2"
Outside Rollers	(6) 5" OD x 3 1/2" with extractable pins.
ICC Bumper	Fixed or Manually moveable with locking pin
Fenders	Stainless Steel Polished Quarter Fenders
Lighting	Full LED
Electrical	One Piece plug and play harness
Tool Box	Steel Lockable 36" x 18" x 18" with Tarp Basket
Adjustable Stops	(2) Moveable Nose roller stops
Wear Strips	36" Rail mounted wear strips

SRO 60 Technical Specification

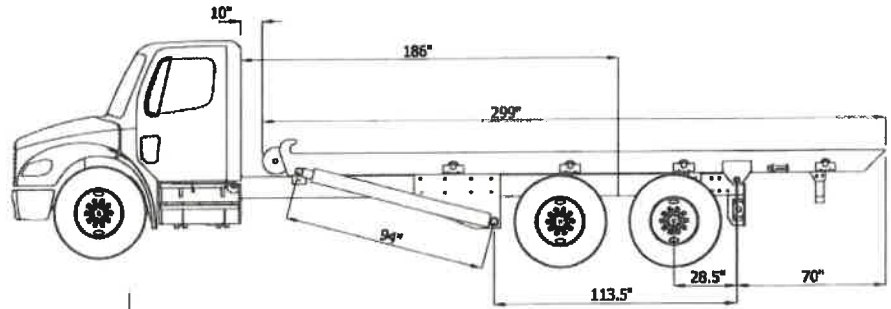

Tie Downs	Dual Ratchet Tiedowns with 3" Straps
Safety Props	Quick Release rail mounted props
Back up Alarm	Audible rear mounted alarm
Warning Lights	Cab mounted PTO and raised rail warning light
Lubrication	Zerk fittings on all wear points

Options

Hitch	Pull or Pup Trailer Hitch Package
Full Fenders	Minimizer Full Tandem Polypropylene
Tarping System	Fully Automatic with adjustable Gantry
Bin Locks	Automatic Container Securement Hooks
Ground Roller	7" Diameter Rear frame roller
Pusher Axle	13,200lb Steerable Hendrickson
On Board Scales	Scale Systems for Air Ride or Mechanical Suspensions



Vendor Contract Information Summary

Vendor Rush Truck Centers of Texas, L.P.
Contact Colton Kruse
Phone (830) 302-5219
Phone Extension 5219
Email krusec@rushenterprises.com
Vendor Website www.rushtruckcenters.com
TIN 74-2786264
Address Line 1 555 IH 35 South, Suite 500
Vendor City New Braunfels
Vendor Zip 78130
Vendor State TX
Vendor Country USA
Delivery Days 10
Freight Terms FOB Destination
Payment Terms NET30 see Exhibit A: Paym
Shipping Terms Freight prepaid by vendor and added to invoice
Ship Via Common Carrier
Designated Dealer No
EDGAR Received Yes
Service-disabled Veteran Owned No
Minority Owned No
Women Owned No
National No
No Foreign Terrorist Orgs Yes
No Israel Boycott Yes
MWBE No
ESCs All Texas Regions
States All States
Contract Name Medium and Heavy-Duty Trucks, Parts, and Maintenance Repair Services
Contract No. 723-23
Effective 12/01/2023
Expiration 11/30/2026
Accepts RFQs Yes
Service Fee Note Vehicle purchase orders are subject to a \$400 service fee



October 9, 2023

Sent Via Email: krusec@rushenterprises.com

Colton Kruse
Rush Truck Center - Austin (Rush Truck Centers of Texas, L.P.)
555 IH 35 South Ste. 200
New Braunfels, TX 78130

Welcome to BuyBoard!

Re: Notice of National Purchasing Cooperative Award; Proposal Invitation No. 723-23, Medium and Heavy Duty Trucks, Parts, and Maintenance Repair Service

Congratulations, The National Purchasing Cooperative (National Cooperative) has awarded your company a BuyBoard® contract based on the above-referenced Proposal Invitation. The contract is effective for an initial one-year term of December 1, 2023, through November 30, 2024, and may be subject to two possible one-year renewals. Please refer to the Proposal Invitation for the contract documents, including the National Purchasing Cooperative Vendor Award Agreement and General Terms and Conditions of the Contract.

To review the items your company has been awarded, please review Proposal Tabulation No. 723-23 at www.buyboard.com/vendor. Only items marked as awarded to your company are included in this contract award, and only those awarded items may be sold through the BuyBoard contract. All sales must comply with the contract terms and must be at or below the awarded pricing as set forth in the General Terms and Conditions.

The contract will be posted on the BuyBoard website as an online electronic catalog(s). **You are reminded that, in accordance with the General Terms and Conditions, all purchase orders from National Cooperative members must be processed through the BuyBoard.** Except as expressly authorized in writing by the Cooperative's administrator, you are not authorized to process a purchase order received directly from a National Cooperative member that has not been processed through the BuyBoard or provided to the Cooperative. If you receive a purchase order directly from a National Cooperative member that you have reason to believe has not been received by the National Cooperative or processed through the BuyBoard, you must promptly forward a copy of the purchase order by e-mail to info@buyboard.com

A list of National Cooperative members is available on the buyboard.com website. Once the contract is active, the BuyBoard vendor relations staff will be contacting you to assist with resources available and provide any support you may need as an awarded BuyBoard vendor.

On behalf of the National Cooperative, we are looking forward to your participation in the program. If you have any questions, feel free to contact me at 800-695-2919.

Sincerely,

Ava Benford, Cooperative Procurement Manager
Texas Association of School Boards, Inc.,
Procurement Administrator for the National Purchasing Cooperative

v.02.01.2021

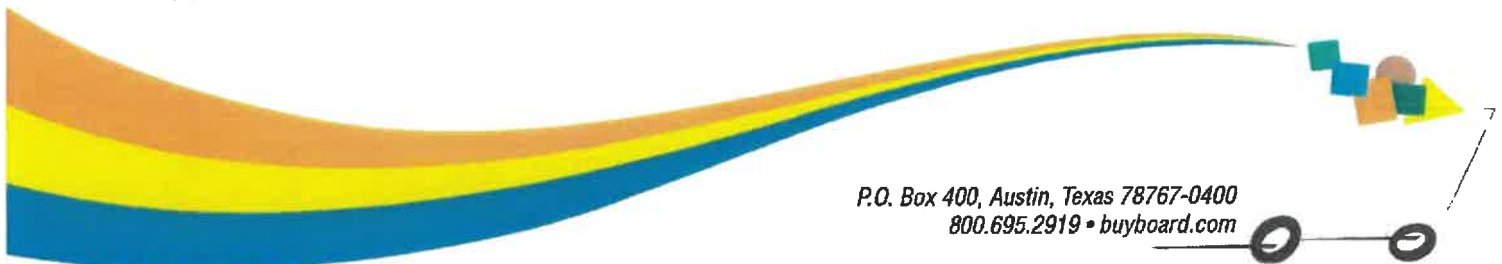

P.O. Box 400, Austin, Texas 78767-0400
800.695.2919 • buyboard.com



The Local Government Purchasing Cooperative

For the Period 12/1/2023 to 11/30/2024

Final Catalog Award Report for Medium and Heavy-Duty Trucks, Parts, and Maintenance
Repair Service No. 723-23

200. Base Model Price for Peterbilt Model 589

Vendor Name	Vendor Brand and Model Number	Bid Price	Award
Rush Truck Centers of Texas, L.P.	Peterbilt 589	\$136,418.00	Yes

201. Base Model Price for Peterbilt Model 548

Vendor Name	Vendor Brand and Model Number	Bid Price	Award
Rush Truck Centers of Texas, L.P.	Peterbilt 548	\$84,760.00	Yes

202. Base Model Price for Peterbilt Model 567

Vendor Name	Vendor Brand and Model Number	Bid Price	Award
Rush Truck Centers of Texas, L.P.	Peterbilt 567	\$123,327.00	Yes

203. Base Model Price for Peterbilt Model 537

Vendor Name	Vendor Brand and Model Number	Bid Price	Award
Rush Truck Centers of Texas, L.P.	Peterbilt 537	\$74,416.00	Yes

204. Base Model Price for Peterbilt Model 536

Vendor Name	Vendor Brand and Model Number	Bid Price	Award
Rush Truck Centers of Texas, L.P.	Peterbilt 536	\$74,765.00	Yes

205. Base Model Price for Peterbilt Model 535

Vendor Name	Vendor Brand and Model Number	Bid Price	Award
Rush Truck Centers of Texas, L.P.	Peterbilt 535	\$73,625.00	Yes



BuyBoard Current Vendors - Texas

Vendor	Address Line 1	City	State	ZIP	Effective	Expiration	Contract
RS Commercial Construction, LLC(E) (I)(T)	17250 Dallas Parkway	Dallas	TX	75248	4/1/2024	3/31/2029	Job Order Contracting (RSMMeans) 728-24
RTC Inc(M)(E)(I)(T)	300 E Sunset Rd	El Paso	TX	79922	4/1/2023	3/31/2026	Radio Communications and Video Recording Products and Services 696-23
Rubber Flooring Systems dba RFS Sports(E)(I)(T)	375 COLUMBIA MEMORIAL PKWY	KEMAH	TX	77565	6/1/2024	5/31/2027	Indoor and Outdoor Sports Surfaces, Repair and Renovation and Gym Floor Refinishing 737-24
Rubber Flooring Systems dba RFS Sports(E)(I)(T)	375 COLUMBIA MEMORIAL PKWY	KEMAH	TX	77565	4/1/2025	3/31/2028	Athletic & Physical Education Supplies & Equipment 766-25
Rudy Rodriguez dba 421 Productions (E)(I)(T)	1944 E. Polk St.	Brownsville	TX	78520	12/1/2024	11/30/2027	Stage and Theater Curtains, Lighting, Sound Systems, and Supplies 752-24
Rules of Engagement Tactical, LLC (E)(I)(T)	710 E. Park Blvd, Ste 206	Plano	TX	75074	4/1/2023	3/31/2026	Public Safety and Firehouse Supplies and Equipment 698-23
Rush Truck Centers of Texas LP /dba/ Rush Bus Centers(E)(I)(T)	16345 IH-35 North	Selma	TX	78154	12/1/2023	11/30/2026	School Buses, Options and Parts 722-23
Rush Truck Centers of Texas, L.P.(E)(I)(T)	555 IH 35 South, Suite 500	New Braunfels	TX	78130	12/1/2023	11/30/2026	Medium and Heavy-Duty Trucks, Parts, and Maintenance Repair Services 723-23
Rush Truck Centers of Texas, L.P.(E)(I)(T)	555 IH 35 South, Suite 500	New Braunfels	TX	78130	12/1/2023	11/30/2026	Vehicles, Police Motorcycles, Parts, and Maintenance Repair Services 724-23
Rushing2Winders LLC dba Winders Sales & Services(M)(E)(I)(T)	2910 S.E. Stallings Dr.	Nacogdoches	TX	75961	10/1/2024	9/30/2027	Custodial Supplies and Equipment 747-24
Ryan Sanders Sports Services, LLC /dba/ RS3 Turf(E)(I)(T)	3400 E. Palm Valley Blvd.	Round Rock	TX	78665	6/1/2024	5/31/2027	Indoor and Outdoor Sports Surfaces, Repair and Renovation and Gym Floor Refinishing 737-24
Rydin Decal(E)(I)(T)	700 Phoenix Lake Avenue	Steamwood	IL	60107	12/1/2023	11/30/2026	Copy-Print and Document Management Services 716-23
S & S HVAC Equipment(M)(E)(I)(T)	18085 West Little York	Katy	TX	77449	12/1/2023	11/30/2026	HVAC Equipment, Supplies, and Installation of HVAC Equipment 720-23
S & S Worldwide Inc(E)(I)(T)	75 MILL ST	Colchester	CT	06415	11/1/2024	10/31/2027	Instructional Materials (Non-Adopted) for PK-12, Special Education, & Career and Technology 748-24
S & S Worldwide Inc(E)(I)(T)	75 MILL ST	Colchester	CT	06415	11/1/2024	10/31/2027	Classroom & Teaching Aids, Supplies, & Equipment 750-24
S & S Worldwide Inc(E)(I)(T)	75 MILL ST	Colchester	CT	06415	4/1/2025	3/31/2028	Athletic & Physical Education Supplies & Equipment 766-25

(M) - MWBE (E) - EDGAR Received (D) - Designated Dealer (I) - No Israel Boycott (T) - No Foreign Terrorist Orgs

From: [VALDEZ, MARTIN J.](#)
To: [JARAMILLO, DAVID M.](#)
Subject: RE: Fleet Approvals New Vehicle
Date: Thursday, September 18, 2025 10:37:00 AM

Thanks David.

From: JARAMILLO, DAVID M. <dmjaramillo@santafenm.gov>
Sent: Thursday, September 18, 2025 9:55 AM
To: VALDEZ, MARTIN J. <mjvaldez@santafenm.gov>
Subject: Fleet Approvals New Vehicle

To whom it may concern,

I am writing to express that in the case of **ESD, Fire, Transit, Airport, Complete streets 1 ton and above**, I'm not required to review any of their purchases. This is because I don't over see their fleet or manage those assets.

Please reach out if you have any questions.

David Jaramillo

Fleet section manager

(505)4704682

(505)9552351

Signature: *Martin J Valdez*

Email: mjvaldez@santafenm.gov

Signature: 

Email: jdroach@santafenm.gov

Signature: DEBORA TRUJILLO
DEBORA TRUJILLO (Jan 6, 2026 14:55:43 MST)

Email: dctrujillo@santafenm.gov











GB-550-Rush Truck Centers of New Mexico, Inc.

Final Audit Report

2026-01-09

Created:	2026-01-07
By:	ALYSSA PEREZ (aeperez@santafenm.gov)
Status:	Signed
Transaction ID:	CBJCHBCAABAAGQR7T7kaMVDtPeTpBrKL2Rvkz2T5_C-J

"GB-550-Rush Truck Centers of New Mexico, Inc." History

-  Document created by ALYSSA PEREZ (aeperez@santafenm.gov)
2026-01-07 - 5:43:16 PM GMT- IP address: 63.232.20.2
-  Document emailed to ALYSSA PEREZ (aeperez@santafenm.gov) for filling
2026-01-07 - 5:44:30 PM GMT
-  Form filled by ALYSSA PEREZ (aeperez@santafenm.gov)
Form filling Date: 2026-01-07 - 5:44:56 PM GMT - Time Source: server- IP address: 63.232.20.2
-  Document emailed to ajhopkins@santafenm.gov ajhopkins@santafenm.gov (ajhopkins@santafenm.gov) for signature
2026-01-07 - 5:44:58 PM GMT
-  Email sent to financecommitteemeeting@santafenm.gov bounced and could not be delivered
2026-01-07 - 5:45:05 PM GMT
-  Email sent to governingbody@santafenm.gov bounced and could not be delivered
2026-01-07 - 5:45:15 PM GMT
-  Email viewed by ajhopkins@santafenm.gov ajhopkins@santafenm.gov (ajhopkins@santafenm.gov)
2026-01-08 - 5:20:55 PM GMT- IP address: 104.47.65.254
-  Document e-signed by ajhopkins@santafenm.gov ajhopkins@santafenm.gov (ajhopkins@santafenm.gov)
Signature Date: 2026-01-08 - 5:22:21 PM GMT - Time Source: server- IP address: 63.232.20.2
-  Document sent to JoAnn Lovato (jdlovato@santafenm.gov) and Travis Dutton-Leyda (tkduttonleyda@santafenm.gov) for signature. One of them to sign
2026-01-08 - 5:22:23 PM GMT
-  Email sent to governingbody@santafenm.gov bounced and could not be delivered
2026-01-08 - 5:22:35 PM GMT

 Email sent to financecommitteemeeting@santafenm.gov bounced and could not be delivered

2026-01-08 - 5:22:40 PM GMT

 Email viewed by JoAnn Lovato (jdlovato@santafenm.gov)

2026-01-08 - 5:47:26 PM GMT- IP address: 63.232.20.2

 Email viewed by Travis Dutton-Leyda (tkduttonleyda@santafenm.gov)

2026-01-08 - 6:19:25 PM GMT- IP address: 98.97.114.141

 Document e-signed by Travis Dutton-Leyda (tkduttonleyda@santafenm.gov)

Signature Date: 2026-01-09 - 11:09:54 PM GMT - Time Source: server- IP address: 63.232.20.2

 Agreement completed.

2026-01-09 - 11:09:54 PM GMT