

Public Comment:

There were no public comments offered.

Board Action:

Member Biedscheid moved in case 2025-010695-HDRB, at 549 ½ Agua Fria to designate the residence as contributing with the south as the primary, excluding the non-historic windows, and designate the non-historic yard walls as non-contributing. Member Degnan seconded. The motion passed with the Board voting unanimously (4-0).

- f. **2025-010839-HDRB, 433 Calle La Paz**, Downtown & Eastside Historic District, contributing, Martinez Architecture Studio, agent for John C. Gregory and Pamela S Austin Revocable Trusts, owners, requests primary façade designation of the main residence, a historic status review with primary façade designation, if applicable, for a casita and a garage structure.

Lani McCulley presented the case and staff recommendation. Staff recommended the historic status of the main residential structure be maintained as contributing with the north façade (R1), which retains the original and design designated as the primary facade, the garage be designated as contributing with the west (G4) as the primary façade and the guest house and yard walls be designated as non-contributing due to their age per 14-5.2(C) Designation of Significant, Contributing or Noncontributing Status Within Historic Districts.

Acting Chair Bienvenu asked staff to address the west facade of the primary residence, as it was indicated that the south and the east were mentioned as not being primary in the past, which implies that both the north and the west have been considered primary. Secondly, that west elevation was noted by the HCPI as the oldest portion of the house, and it's quite visible from the street. It's by far the most visible portion of the house from the street, and it seems to retain at least one, if not two, historic windows. He asked if there was any reason why the west was not recommended to be primary as well, or would staff agree that that could also be considered primary?

Ms. McCulley stated that the 2001 case did not actually mention either the north or the west facades at all. So, there was no indication which was considered primary or if both were, and in discussing it on site with Mr. Martinez, we both agreed that it's very possible that both were intended to be primary, but we were unsure.

Acting Chair Bienvenu asked why staff wouldn't recommend the west, the very prominent west facade that's the oldest portion of the house, and seems to have been considered primary in the past to retain it or to be designated formally tonight as also primary.

Ms. McCulley stated it was an attempt to limit the number of primary facades.

Richard Martinez, previously sworn in, agreed with the recommendations of the staff and felt the reason staff only recommended the north elevation, not the west elevation, is because John Murphy in the historic report stated that the primary house is designated as a contributing structure and the most important facade is the front north facing elevation which been the least affected by additions and clearly communicates the building's original and historic character. Character-defining features of this facade include its original horizontal massing, window openings that contain older two-over-one wood sash windows, and the brick cornice, or perhaps because that is where the front door is, and it is character-defining the house, and that's the reason why John Murphy recommended only that facade as being the primary facade for the main house.

Mr. Martinez stated that there are non-contributing elements of that facade that should not be included in the designation of the primary. This included the portal in front of the house, which is a different style from the house and was possibly added later. The wood columns and the beams on the portal have been painted, and the paint possibly hides damage to the wooden elements there. He said he may want to replace those because restoration may not be possible. He said he noticed that the recommended elevations for the primary facade did not include this portal. So, he wanted to make sure that the portal is not included in that primary facade designation. Also, the window that is next to the door is non-historic according to the window report from Ra Patterson, is it is not. The plan may be to open this window up to being larger to match the historic windows on the facade, so since it is not historic, it should be excluded as well, because it is a blemish on the beautiful facade. He said it's too bad that the primary facade designation precludes the idea of expanding the portal to be symmetrical with the house, since the portal is only two-thirds of the length of the house behind it. He also pointed out that the facade that is recommended as primary by the staff includes a small eastern portion, which is an addition for a bathroom, which does not have the same details as the main portion of the facade. If that is designated as primary, he will not be able to do any addition or work within ten feet of that facade. That would affect a portal or other changes for the back area of the house, off the kitchen. So, he wanted this to be excluded from the primary as well. He agreed with the staff recommendation for the yard walls and the guest house.

Director Lamboy pointed out that while at the site visit earlier in the day, there is a window replacement on the south elevation closest to Calle La Paz that is recent, which was not approved, and the window approved in 2001 had a different mutton pattern than what has been replaced. There is still disturbed stucco around the window. The problem with illegal window replacement is that there are also building code standards that apply and have to do with fire rating. Because this property is not five feet stepped back from the property line. She shared this to alert Mr. Martinez that this issue will come up when a building permit is being sought. She also stated that the applicant should not talk about what is being planned as a basis for designating primary facades, but rather whether the finishes or features are historic.

Mr. Martinez stated he understood about the window replacement, though it was done before the current owner.

Member Degnan asked if the comments about the recommended primary facade and Mr. Martinez's professional approaches to addressing, for example, the portal that is not expanding across the front of the building, if changes like that alter the facade that the board is investigating.

Director Lamboy stated that it would alter the primary façade significantly if there was no proof that there was a portal there that was much longer.

Acting Chair Bienvenu stated he understood the comments from the applicants' representative to be directed at excluding certain features because they were not character-defining or non-historic from the facade designations. He also stated that it seems there was a request to exclude a lot for the only facade that's recommended as primary. This is why the importance of the west street-facing façade, on page eight of Mr. Murphy's report, states that the west elevation holds the oldest portion of the house, and it looks like some historic windows that would not be protected if it were not a primary façade. It seems to be extremely important to protect both facades.

Mr. Martinez stated that his recommendation for exclusions does not mention any of what the historian mentions as the character-defining elements of that facade, like the coping, windows, door, or things like that.

Public Comment:

Ms. Stefanie Beninato, previously sworn in, stated was happy that Director Lamboy brought up talking about what remodel items are desired because, as a professional architect who has appeared in front of this board numerous times, Mr. Martinez should know that he shouldn't be talking about what he wants to do. She supported the idea not only of having both the garage and the main houses contributing to the facades recommended as primary, but also included the street-facing façade that is said to be the oldest part with original windows. She felt it was important that it was publicly visible and important to be preserved. She did not feel it should include the portal, but felt the board could be very clear that it is excluding the portal as part of that primary facade.

Board Action:

Member Biedscheid moved in case 2025-010839-HDRB, at 433 Calle La Paz to retain the main residence as contributing with the north façade as primary excluding the portal which appears to be new based on the HCPI that refers to non-weathered wood and a new flooring and decking, excluding the side lite which per the HCPI is likely to not be original, and excluding the eastern addition with no brick coping, and to designate the garage as contributing with the west as primary, and the casita and yard walls as non-

contributing. Member Mather seconded. The motion passed with the Board voting unanimously (4-0).

- g. 2025-010840-HDRB, 815 E. Alameda St. Unit 8**, Downtown & Eastside Historic District, William Kleinschmidt, agent for Nancy Abruzzo Holdings LLC, owner, proposes to construct yard walls with pedestrian gates to the maximum allowable height of 4'-6".

Lani McCulley presented the case and staff recommendation. Staff recommended approval of the application as it complies with 14-5.2(D) General Design Standards for all Historic Districts, and 14-5.2(E) Downtown and Eastside Design Standards.

Member Biedscheid questioned if, when staff writes an administrative approval for a 4'0" high or less wall, there is a required break in that length.

Director Lamboy stated that it is a zoning standard in terms of the breaks and the changes that apply throughout the city, regardless of height.

Member Biedscheid asked with respect to the coyote circular fence it went behind the tree or in front of the tree, along the street.

Ms. McCulley stated that it is behind the tree, so that the tree is on the side of the street.

Member Aguilar Medrano asked if the steel planters from the previous application were redesigned and part of this application.

Ms. McCulley stated the planters were denied at the last hearing, and the applicants have chosen not to build them.

William Kleinschmidt, 1919 5th Street, Suite D, Santa Fe, was sworn in. He had nothing further to add but was available for questions.

Member Biedscheid questioned whether the pedestrian gate was planned as a wood plank gate or a coyote fence gate.

Mr. Kleinschmidt stated that it was planned to be a wooden plank gate.

Member Biedscheid confirmed that there is a mix of elements, including stucco, coyote fencing, and a wood plank gate.

Mr. Kleinschmidt stated she was correct, and the coyote fence that goes around the fruit tree already exists, but three elements are incorrect.



City of Santa Fe
Land Use Department
200 Lincoln Ave.
Santa Fe, New Mexico 87504-0909

PROJECT 2025-010839-HDRB, 433 Calle La Paz, Downtown & Eastside Historic District, contributing,
DESC: Martinez Architecture Studio, agent for John C. Gregory and Pamela S Austin Revocable Trusts, owners, requests primary façade designation of the main residence, a historic status review with primary facade(s) designation, if applicable, for a casita and a garage structure.

CASE NUMBER: 2025-010839--HDRB

PROJECT TYPE: Historic Status Review

LOCATION: 433 CALLE LA PAZ
Santa Fe, NM 87505

CONTACTS: Applicant

M A R T I N E Z P.O. BOX 925
ARCHITECTURE STUDIO

Property Owner

Pamela S Austin

Property Owner

John C Gregory

BOARD ACTION

This is to certify that the Historic Districts Review Board (HDRB) acted on your request at their hearing on Aug 12, 2025. The decision of the Board was to maintained the main residential structure's contributing status and designated the north (R1) as the primary facade excluding the portal which appears to be new based on the HCPI that refers to non-weathered wood and a new flooring and decking, the sidelite window which per the HCPI is likely not original, and excluding the eastern addition wall which has no coping unlike the rest of the house, designated the garage as contributing with the west (G4) as the primary facade, and designated the guesthouse and yard walls as non-contributing due to their age.

For further information please call 505-955-6605.

Sincerely,

Lani McCulley

NOTE: Applicant can use this action letter to apply for construction permit, but the permit shall not be released until the end of the appeal period which starts on the date of filing of the Findings and Conclusions in the City Clerk's office (SFCC 14-3.17(D)). Your permit will be denied if any changes on plans that were not approved by the HDRB or if conditions of approval are not met. **Please attach copies of this letter to all sets when submitting for construction permits.**

City of Santa Fe, New Mexico

memo

DATE: August 12, 2025

TO: Historic Districts Review Board Members

VIA: Heather Lamboy, Planning & Land Use Department Director *HL*
Maggie Moore, Assistant Land Use Director
Gary Moquino, Historic Preservation Division Manager *GM*

FROM: Lani McCulley, Senior Planner, Historic Preservation Division *LGM*

2025-010839-HDRB, 433 Calle La Paz, Downtown & Eastside Historic District, contributing, Martinez Architecture Studio, agent for John C. Gregory and Pamela S Austin Revocable Trusts, owners, requests primary façade designation of the main residence, a historic status review with primary facade(s) designation, if applicable, for a casita and a garage structure.

REFERENCE ATTACHMENTS (Sequentially):

CITY SUBMITTALS

District Standards & yard wall
& fence standards.

Historic Inventory Form

Zoning Review Sheet

Other: [previous case documents]

APPLICANT SUBMITTALS

Proposal Letter

Site Plan/Floor Plan

Elevations

Photographs

Other: [2025 HCPI, window assessments]

STAFF RECOMMENDATION:

Staff recommends the historic status of the main residential structure be maintained as contributing with the north façade (R1), which retains the original and design designated as the primary facade, the garage be designated as contributing with the west (G4) as the primary façade and the guest house and yard walls be designated as non-contributing due to their age per 14-5.2(C) Designation of Significant, Contributing or Noncontributing Status Within Historic Districts.

Sample motions:

Four motions will be required in this case. One motion is required for the designation of the main residence and assignment of primary facade(s), one is required for the designation of the garage and assignment of primary facade(s), one is required for the designation of the casita, and one required for the yard walls.

- a. In case 2025-010839-HDRB, for 433 Calle la Paz, retain the main residence as contributing and designate facades (R1-R6) as primary façade(s).
- b. In case 2025-010839-HDRB, for 433 Calle la Paz, downgrade the main residence to non-contributing.
- c. In case 2025-010839-HDRB, for 433 Calle la Paz, designate the casita as non-contributing due to age, with the understanding that the status could be reviewed for an upgrade in status at a later date.
- d. In case 2025-010839-HDRB, for 433 Calle la Paz, designate the garage as contributing and designate the (north G1, east G2, south G3, and/or west G4) façades as the primary façade(s).
- e. In case 2025-010839-HDRB, for 433 Calle la Paz, designate the garage as non-contributing.
- f. In case 2025-010839-HDRB, for 433 Calle la Paz, designate the yard walls on Calle la Paz and Camino Manzano as non-contributing due to age, with the understanding that the status could be reviewed for an upgrade in status at a later date.

The property lies within the Historic Downtown Archaeological Review District. See Chapter 14, SFCC, Article 14-3.13(B)(1).

BACKGROUND & SUMMARY:

Streetscape:

The area that consists of Calle La Paz was an apple orchard in the 1920s. The properties in the area were developed with larger lots, heterogeneous designs, and houses that, for the most part, do not face the street. The addresses were Acequia Madre until 1938, when they were changed to Calle la Paz and Camino Manzano. Calle la Paz is a dirt road lined with yard walls and wood and wire fencing ranging from three feet to six feet in height at the edge of the road. The houses are set back from the road, from five to ten feet on average. Most of the streetscape is Spanish Pueblo Revival Style, and a few territorial style homes. Of the eight properties on the street, only two have free-standing street-facing garages. All of the properties back up along Camino Manzano. Camino Manzano is also a dirt road lined with yard walls and wood fencing. However, the street also has several structures that sit at the side of the road with no setbacks. The view of the properties on Calle la Paz from the Camino Manzano side consists of the rear of homes and backyard walls, fences, and gates.

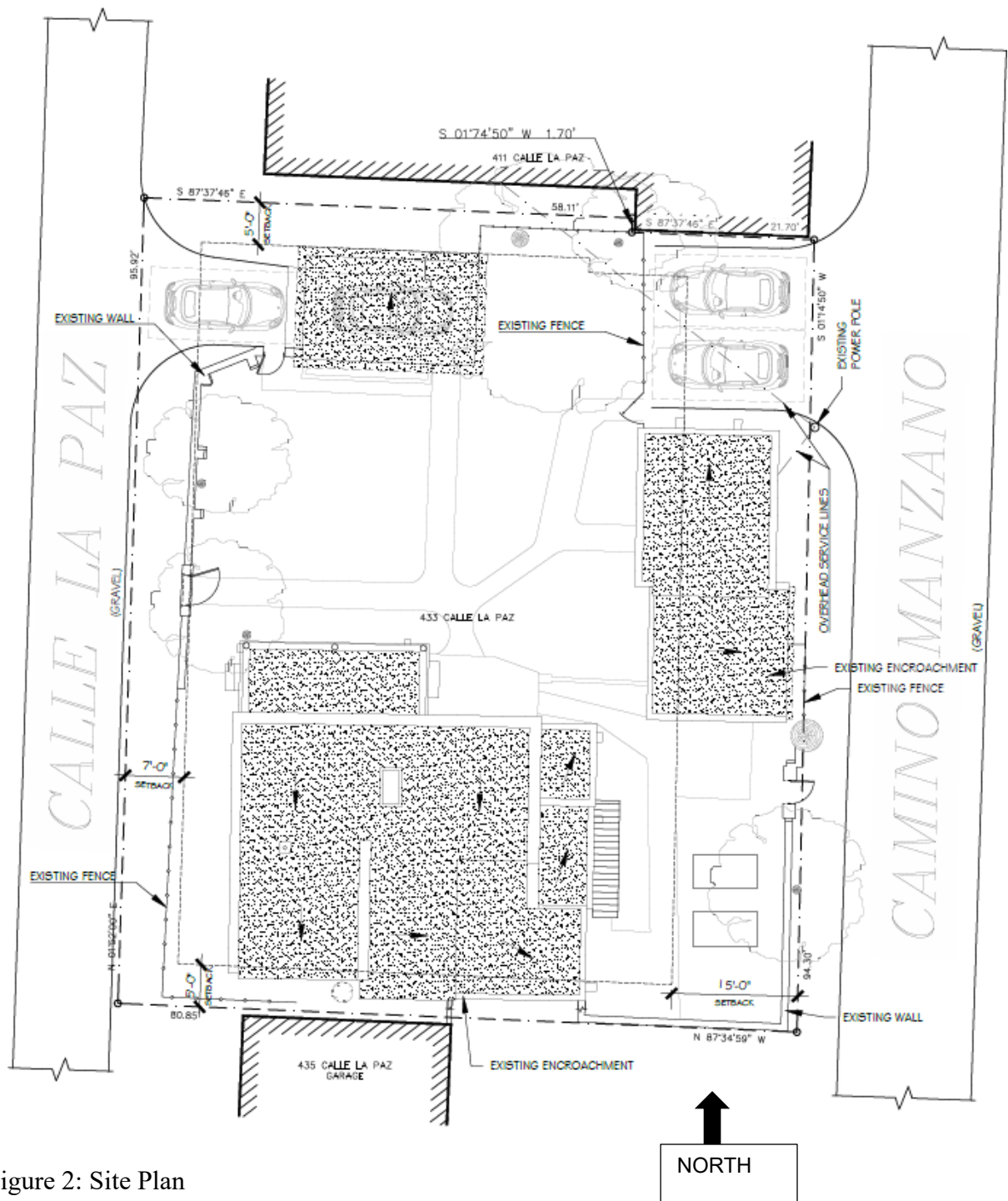

Figure 2: Site Plan

Buildings:



Figure 2: Main Residence

The 1,358 square foot single-family residence at 433 Calle la Paz is listed as contributing to the Downtown and Eastside Historic District. The original portion of the home was constructed in adobe sometime between 1912 and 1930, with four subsequent additions, all of which were constructed before 1970. The residence is a vernacular interpretation of Territorial Style with Pueblo Revival influence in the additions to the historic footprint. The roof heights vary, with most having a brick cornice, which was installed in 2001. The main entrance of the residence faces north and is covered by a portal that is off-center from the elevation due to one of the additions. The recent brick floor of the portal is several feet above ground level, and the roof is supported by wood posts set on concrete pier blocks. The residence retains its original fenestrations with mostly two-over-one wood windows, except one six-over-one wood-clad and one one-over-one vinyl window. The doors are wood, except for one metal door. The residence is stuccoed in cement stucco in “buckskin”. Character-defining elements of the main residence include the original core, original fenestration openings fitted with two-over-one wood windows, and the brick cornice.

The applicant provided a window assessment of the windows and doors throughout the residence. There is a combination of historic and non-historic windows and doors in various stages of wear.



Figure 3: Casita

The 564 square foot casita is listed as non-contributing to the historic district. It was constructed in the early 1980s with frame construction that seems to encompass an older structure on its south end. The casita is a vernacular style with a passive solar design consisting of south-facing clerestory windows and interior brick floors. The main entrance faces west and has a metal panel door and sash windows. The south houses French doors and a sash window, and the upper level has the clerestory windows. The east façade contains wood windows, and the north façade has no openings. According to the window assessment, all windows are non-historic from 1987 to 2015.



Figure 4: Garage

The 264 square foot west-facing garage was constructed before 1958 of hollow clay tile blocks in a Spanish Pueblo Revival style. The roof has been modified with a flat roof with plywood overhang. The vehicle door is a double chevron wood overhead door in a natural color with blue trim surround that matches the blue of the roof overhang. There is a metal light fixture to the south of the door. The south façade holds a non-original 1990 wood pedestrian door painted red, and an eight-lite sash window turned on its side. The window assessment shows this window as a non-historic 1987 window. The north façade has no openings. The garage is a good example of this type of construction and design.



Figure 5: East Yard Wall

There are seventy-inch-tall yard walls along both Calle la Paz and Camino Manzano, which were constructed after 1983. In the 1983 survey photo, a much lower wall was in front of the residence, which was raised in height by 1991 as is illustrated in that survey photo. The west wall contains an arched gate opening that reaches ninety inches and holds a wooden gate. To the south is a seventy-two-inch wood plank fence. The yard wall on Camino Manzano starts at the south corner of the lot and runs to the edge of the guest house. Closer to the guest house is a wooden pedestrian gate topped with a header. At the south end of the guest house starts a seventy-two-inch plank fence that runs for about five to ten feet before ending in a wire fence that is damaged by the overgrown foliage that clings to it.



Figure 6: West Yard Wall

There is a single case on file for the property from 2001. Case H-01-126 was approved for replacing windows, a glass door, and add a new window all on the south and east elevation, raising the roof of the kitchen and installation of coping to match the existing coping, and install an outside stair to the basement on east elevation of the main house and replace the French doors on the south elevation of the guest house. The staff report of the case indicates that the south and east facades of the main residence are non-primary but does not clarify which façade is designated as the primary.

APPLICANT’S REQUEST:

The applicant requests:

- 1) Status confirmation with primary façade designation, if applicable, of the main residence and the casita.
- 2) Status designation with primary façade designation, if applicable, for the garage.
- 3) Status designation of the yard walls on Calle la Paz and Camino Manzano.

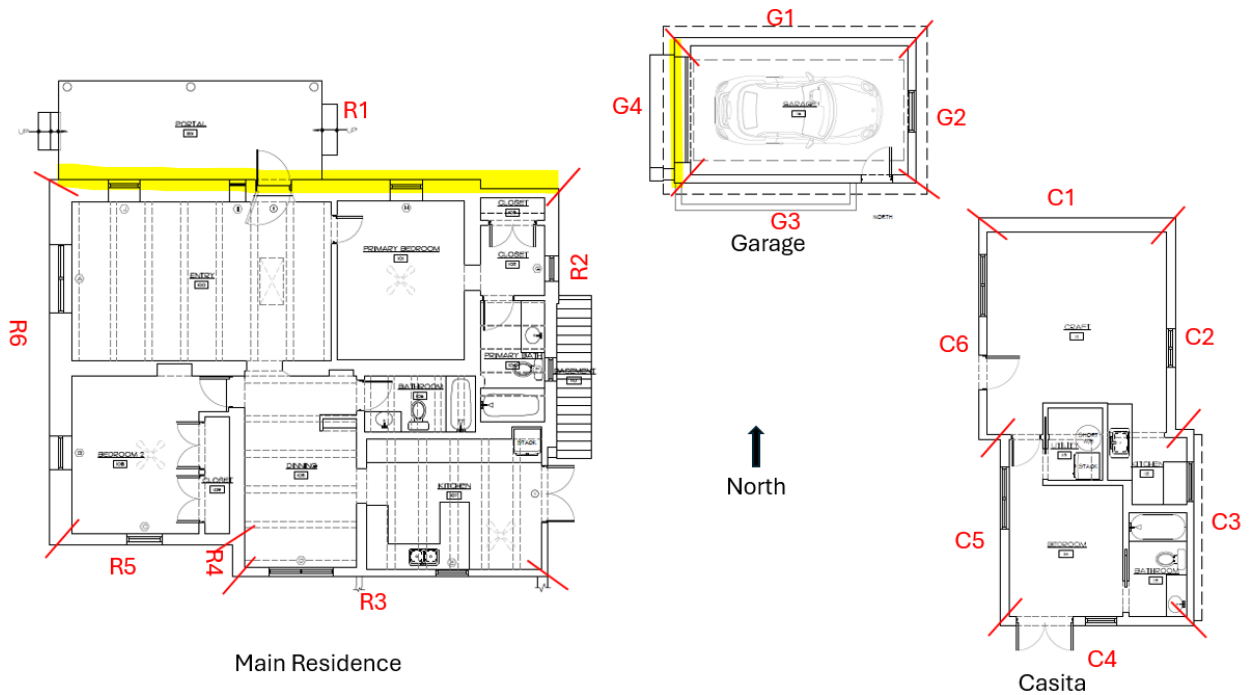

Figure 7: Façade Diagram

RELEVANT CODE CITATIONS:

14-5.2 HISTORIC DISTRICTS

(A) General Provisions

(1) General Purpose

In order to promote the economic, cultural, and general welfare of the people of the *city* and to ensure the harmonious, orderly and efficient growth and *development* of the *city*, it is deemed essential by the *governing body* that the qualities relating to the history of Santa Fe, and a harmonious outward appearance, which preserve *property* values and attract tourists and residents alike, be preserved, some of these qualities being:

- (a) The continued existence and *preservation* of historical areas and *buildings*;
- (b) The continued construction of *buildings* in the historic styles; and
- (c) A general harmony as to style, form, color, height, proportion, texture, and material between *buildings* of historic design and those of more modern design.

(C) Regulation of Significant and Contributing Structures in the Historic Districts

(Ord. No. 2004-26)

(1) Purpose and Intent

It is intended that:

- (a) Each *structure* to be recognized as a physical record of its time, place, and use. Changes that create a false sense of historical *development*, such as the addition of

conjectural features or architectural elements from other *buildings*, shall not be undertaken.

- (b) Changes to *structures* that have acquired historic *significance* in their own right shall be retained and preserved, recognizing that most *structures* change over time;
 - (c) Distinctive features, finishes, and construction techniques or examples of craftsmanship that characterize a *structure* be preserved; and
 - (d) New additions and related or adjacent new construction be undertaken in such a manner that if removed in the future, the original form and integrity of the historic *property* and its environment would be unimpaired.
- (2) Designation of Significant, Contributing, or Noncontributing Status within Historic Districts

(a) Status Designation

Structures within historic districts may be designated a status of "significant," "contributing," or "noncontributing" based upon the definitions of these terms in Article 14-12. Staff shall maintain a record as to the current status of *structures* located in the Historic Districts.

(b) Board Authority to Review Status Designation

- (i) The Board is authorized to change the status of a *structure* or to designate a status for a *structure* with no status designated.
- (ii) A change in status or the designation of a status shall be based upon an evaluation of data provided through survey or other relevant sources of information and the definitions of "significant," "contributing," or "noncontributing."

(e) Appeals (Ord. No. 2009-42 § 16)

Decisions made by the historic districts review board may be appealed to the *governing body* as set forth in Section 14-3.17.

(f) Restoration of Status

If a *property owner* makes changes to a *structure* without the proper *city* approvals, which result in the lowering of the *structure's* status, staff or the board may require the *property owner* to restore the *structure* such that its former status is restored.

14-12 Significant Structure:

A structure located in a historic district that is approximately fifty years old or older, and that embodies distinctive characteristics of a type, period, or method of construction. For a structure to be designated as significant, it must retain a high level of historic integrity. A structure may be designated as significant:

- (A) for its association with events or persons that are important on a local, regional, national, or global level; or
- (B) if it is listed on or is eligible to be listed on the State Register of Cultural Properties or the National Register of Historic Places.

14-12 Contributing Structure:

A structure, located in a historic district, approximately fifty years old or older, that helps to establish and maintain the character of that historic district. Although a contributing structure is not unique in itself, it adds to the historic associations or historic architectural design qualities that are significant for a district. The contributing structure may have had minor alterations, but its integrity remains.

14-12 Noncontributing Structure:

A structure, located in an H district, that is less than fifty years old or that does not exhibit sufficient historic integrity to establish and maintain the character of the H District.

14-12 Primary Façade:

One or more principal faces or elevations of a building with features that define the character of the building's architecture.

14-12 Historic Compound

An identifiable grouping of historic resources, including buildings, structures, and landscaping elements, as described in Section 14-5.2(K)(2)(a). Historic compounds may be comprised of more than one lot.

(E) Downtown and Eastside Design Standards

The *governing body* recognizes that a style of architecture has evolved within the *city* from the year 1600 to the present characterized by construction with *adobe*, hereafter called "old Santa Fe style", and that another style has evolved, hereafter called "recent Santa Fe style", which is a *development* from, and an elaboration of the old Santa Fe style, with different materials and frequently with added decorations.

(1) Old Santa Fe Style

Old Santa Fe style, characterized by construction with *adobe*, is defined as including the so-called "pueblo" or "pueblo-Spanish" or "Spanish-Indian" and "territorial" styles and is more specifically described as follows:

- (a) With rare exception, *buildings* are of one *story*, few have three stories, and the characteristic effect is that the *buildings* are long and low. Roofs are flat with a slight *slope* and surrounded on at least three sides by a firewall of the same color and material as the *walls* or of brick. Roofs are never carried out beyond the line of the *walls* except to cover an enclosed *portal* or *porch* formed by setting back a portion of the *wall* or to form an exterior *portal*, the outer edge of the roof being supported by wooden columns. Two-story construction is more common in the territorial than in other sub-styles, and is preferably accompanied by a balcony at the level of the floor of the second *story*. Façades are flat, varied by inset *portales*, exterior *portales*, projecting vigas or roof beams, canales or water-spouts, flanking buttresses and wooden lintels, architraves and cornices, which, as well as doors, are frequently carved, and the carving may be picked out with bright colors. Arches are almost never used except for nonfunctional arches, often slightly ogive, over gateways in freestanding *walls*;
- (b) All exterior *walls* of a *building* are painted alike. The colors range from a light earth color to a dark earth color. The exception to this rule is the protected space under *portales*, or in church-derived designs, inset panels in a *wall* under the roof, in

which case the roof overhangs the panel. These spaces may be painted white or a contrasting color or have mural decorations.

- (c) Solid *wall* space is always greater in any façade than window and door space combined. Single panes of glass larger than thirty (30) inches in any dimension are not permissible except as otherwise provided in this section;
 - (d) The rule as to flat roofs shall not be construed to prevent the construction of skylights or installation of air conditioning devices, or any other necessary roof *structures*, but such *structures* other than chimneys, flues, vents and aerials, shall be so placed as to be concealed by the firewall from the view of anyone standing in the *street* on which the *building* fronts;
 - (e) True old Santa Fe style *buildings* are made of *adobe* with mud plaster finish. Construction with masonry blocks, bricks, or other materials with which the *adobe* effect can be simulated is permissible, provided that the exterior *walls* are not less than eight (8) inches thick and that geometrically straight façade lines are avoided. Mud plaster or hard plaster simulating *adobe*, laid on smoothly, is required; and
 - (f) It is characteristic of old Santa Fe style commercial *buildings* to place a *portal* so that it covers the entire sidewalk, the columns being set at the curb line.
- (2) Recent Santa Fe Style

Recent Santa Fe style intends to achieve harmony with historic *buildings* by *retention* of a similarity of materials, color, proportion, and general detail. The dominating effect is to be that of *adobe* construction, prescribed as follows:

- (a) No *building* shall be over two stories in height in any façade unless the façade shall include projecting or recessed *portales*, *setbacks*, or other design elements;
- (b) The combined door and window area in any *publicly visible* façade shall not exceed forty percent of the total area of the façade except for doors or windows located under a *portal*. No door or window in a *publicly visible* façade shall be located nearer than three (3) feet from the corner of the façade;
- (c) No cantilevers shall be permitted except over projecting vigas, beams, or wood corbels, or as part of the roof *treatment* described below;
- (d) No less than eighty percent of the surface area of any *publicly visible* façade shall be *adobe* finish, or stucco simulating *adobe* finish. The balance of the *publicly visible* façade, except as above, may be of natural stone, wood, brick, tile, terra cotta, or other material, subject to approval as hereinafter provided for *building permits*;
- (e) The *publicly visible* façade of any *building* and of any adjoining *walls* shall, except as otherwise provided, be of one color, which color shall simulate a light earth or dark earth color, matte or dull finish, and of relatively smooth texture. Façade surfaces under *portales* may be of contrasting or complementary colors. Windows, doors, and *portals* on *publicly visible* portions of the *building* and *walls* shall be of one of the old Santa Fe styles; except that *buildings* with *portals* may have larger plate glass areas for windows under *portals* only. Deep window recesses are characteristic, and
- (f) Flat roofs shall have not more than thirty (30) inches overhang.

A R C H I T E C T U R E
M A R T I N E Z
S T U D I O P C

TEL (505) 989-4958 MAIL: P O BOX 925 SANTA FE NM 87504
1524 PASEO DE PERALTA — STUDIO@MARTINEZARCH.COM

STATUS REVIEW

433 Calle La Paz

July 14, 2025

Downtown/Eastside Historic District, Contributing status

EXISTING CONDITIONS:

On behalf of the property owners, John Gregory and Pamela Austin, the attached application requests a status review and primary elevation designation of the above-referenced property.

Sincerely,

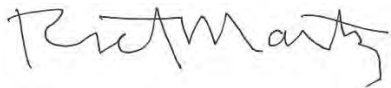

Richard Martinez
Martinez Architecture Studio PC

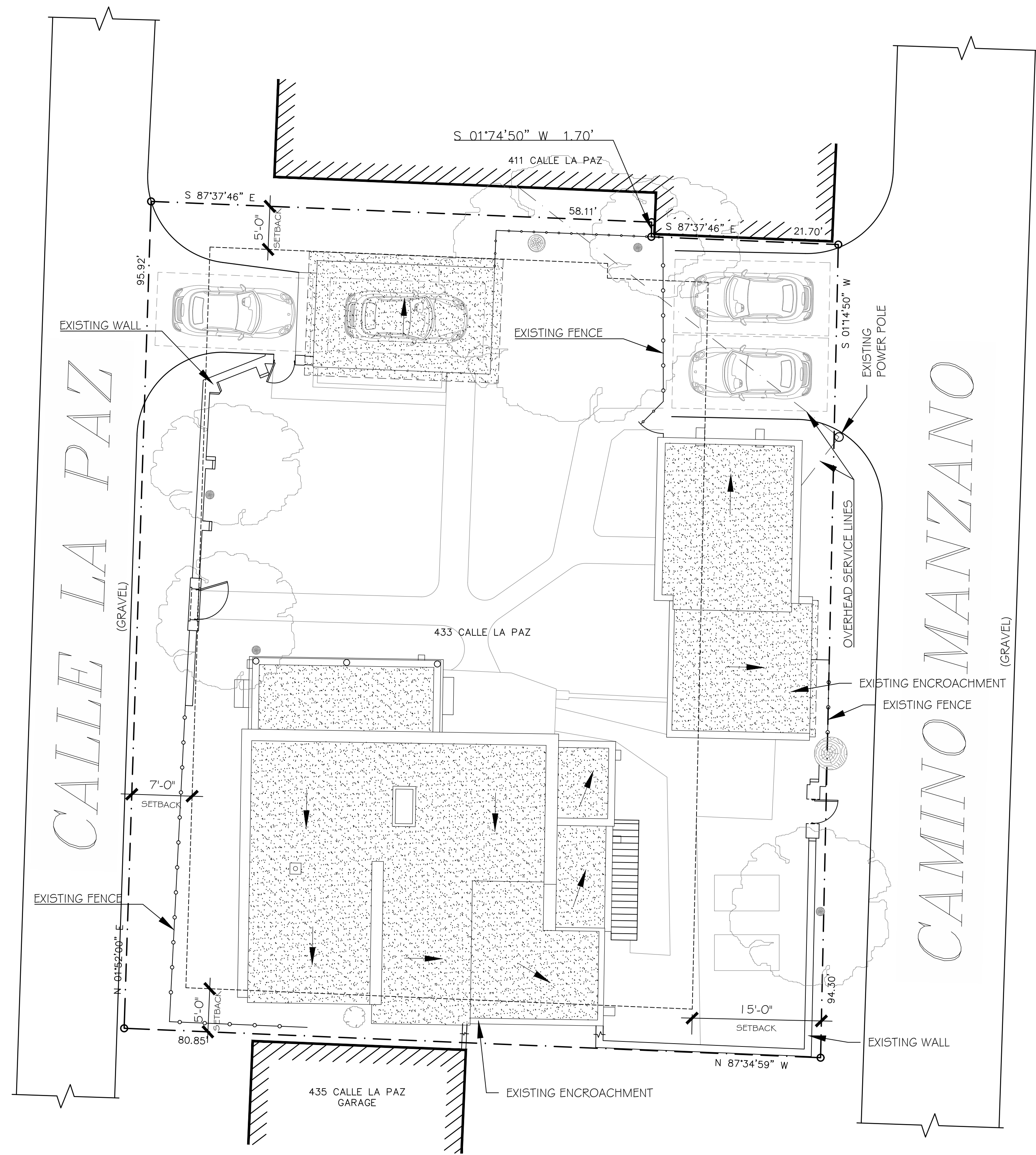

1 EXISTING SITE
 A-1.0 SCALE: 1/8" = 1'-0"

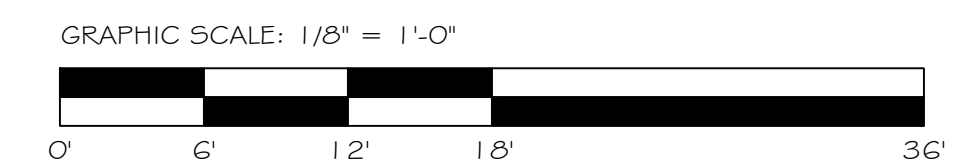
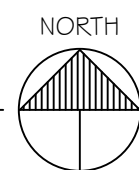

MARTINEZ
 ARCHITECTURE
 STUDIO PC
 1524 PASEO DE PERALTA SANTA FE
 505.989.4958 studio@martinezarch.com

RENOVATION
 433 CALLE LA PAZ
 S A N T A F E ,
 N E W M E X I C O

JULY 3, 2025

EXISTING
 SITE

A
 1.0

SET #
 AUSTIN-GREGORY - 2509

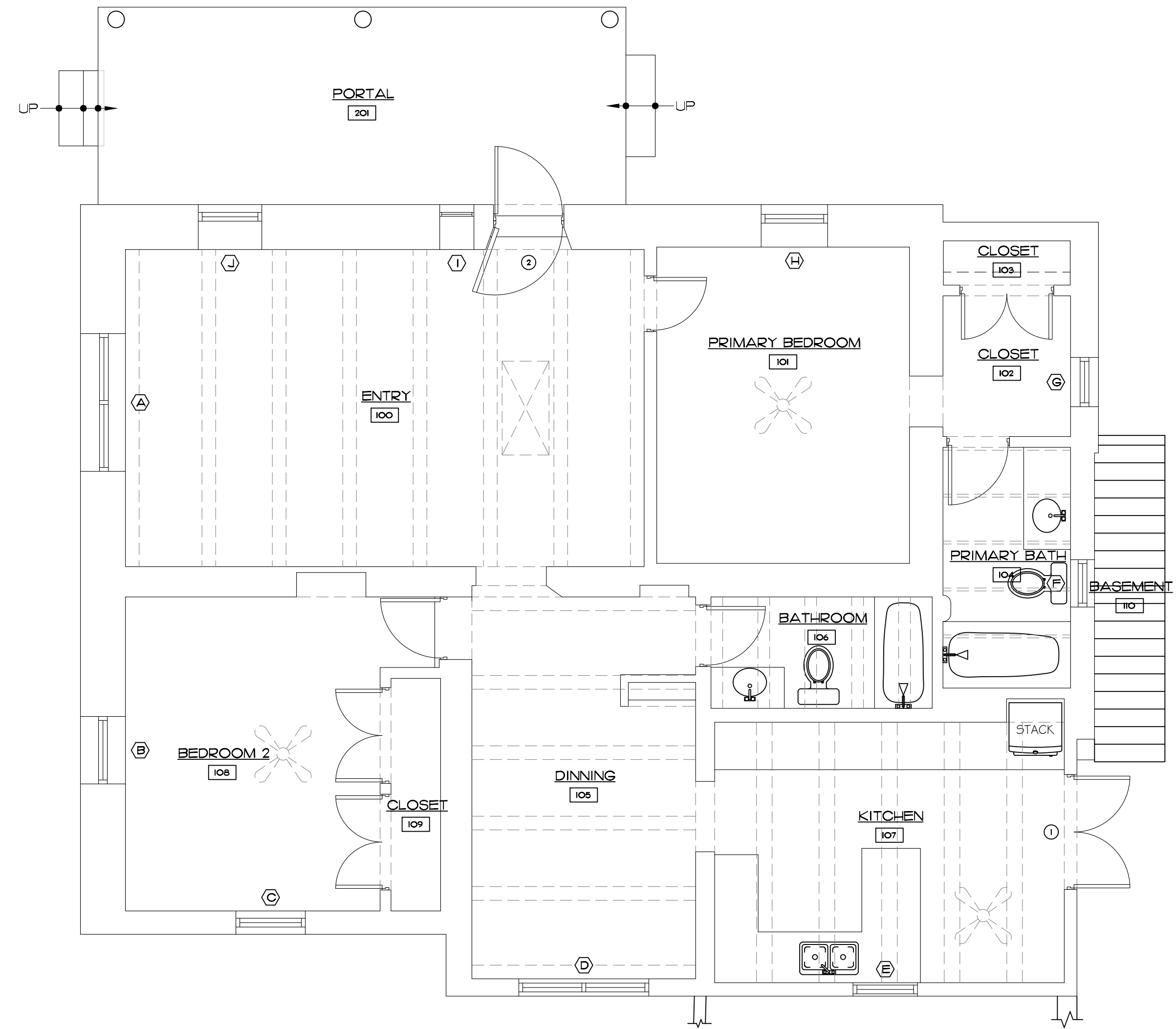

1
A-3.0 EXISTING FLOOR PLAN NORTH
SCALE: 1/4" = 1'-0"

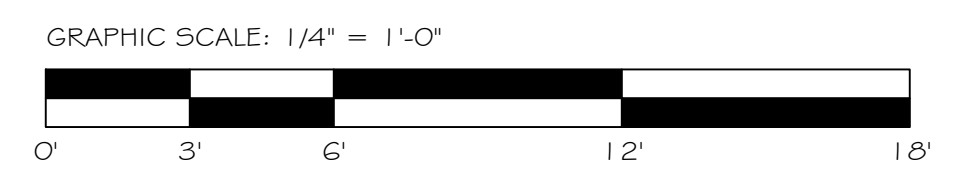

MARTINEZ
ARCHITECTURE
STUDIO PC
1524 PASEO DE PERALTA SANTA FE
505.989.4958 studio@martinezarch.com

RENOVATION
433 CALLE LA PAZ
SANTA FE,
NEW MEXICO

JULY 3, 2025

MAIN
HOUSE -
EXISTING
FLOOR PLAN

A
3.0

SET #
AUSTIN-GREGORY - 2509

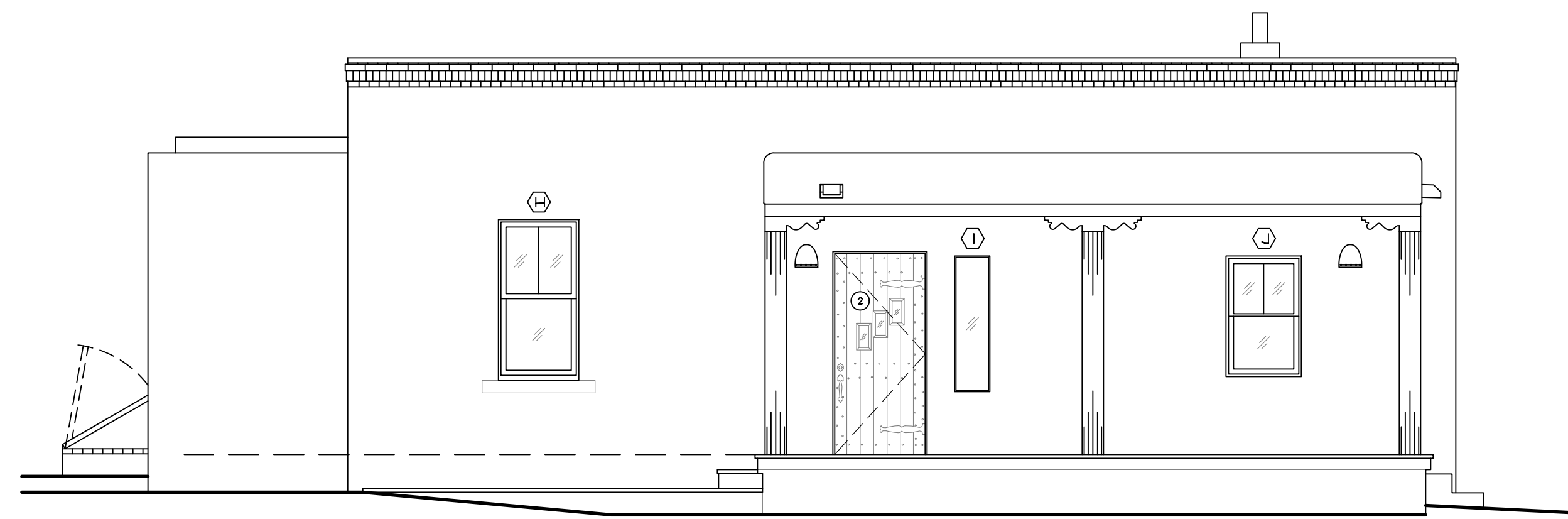

2 EXISTING NORTH ELEVATION
A-4.0 SCALE: 1/4" = 1'-0"

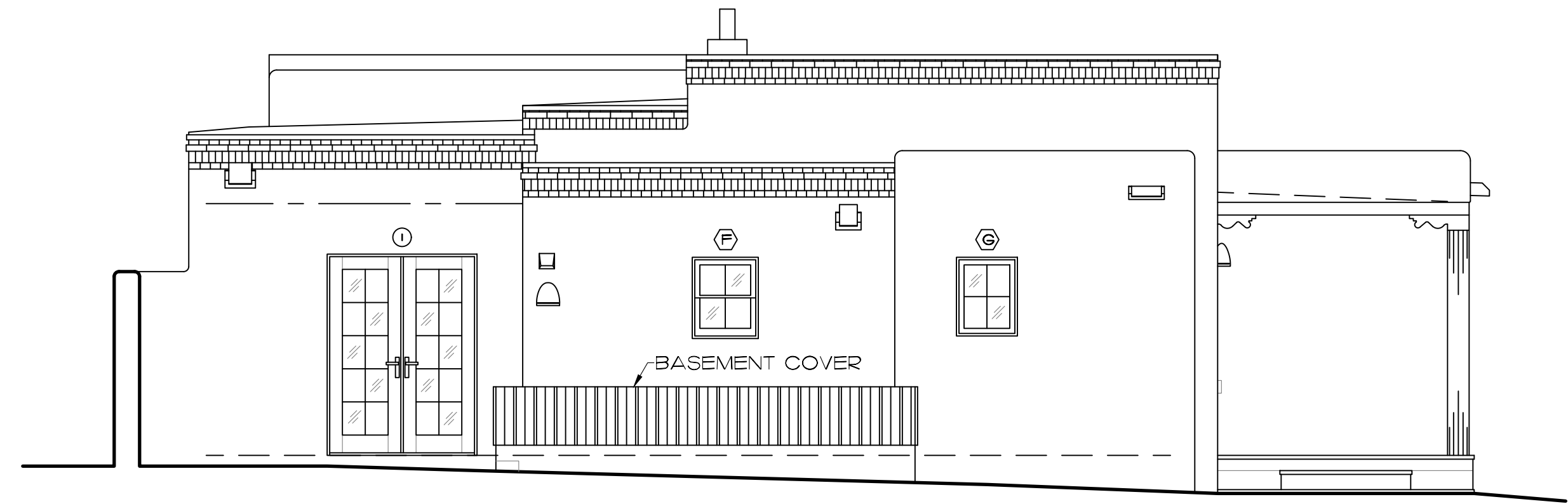

1 EXISTING EAST ELEVATION
A-4.0 SCALE: 1/4" = 1'-0"

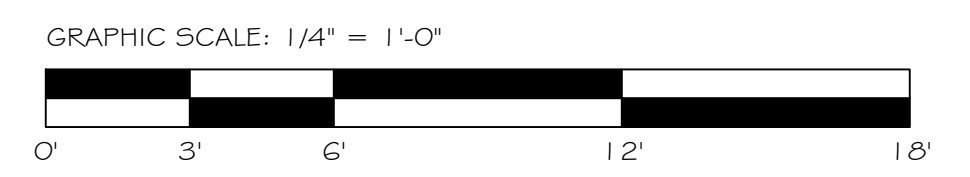

MARTINEZ
ARCHITECTURE
STUDIO PC
1524 PASEO DE PERALTA SANTA FE
505.989.4958 studio@martinezarch.com

RENOVATION
433 CALLE LA PAZ
SANTA ANITA FEE
NEW MEXICO

JULY 3, 2025

MAIN
HOUSE -
NORTH &
EAST
ELEVATIONS

A
4.0

SET #

AUSTIN-GREGORY - 2509

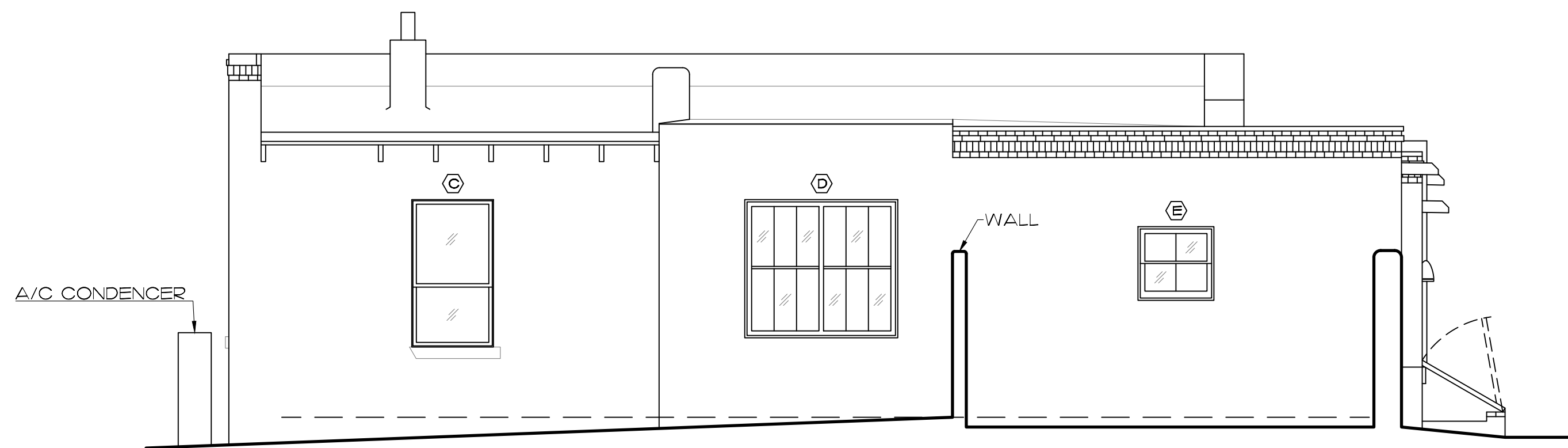

2 EXISTING SOUTH ELEVATION
A-4.1 SCALE: 1/4" = 1'-0"

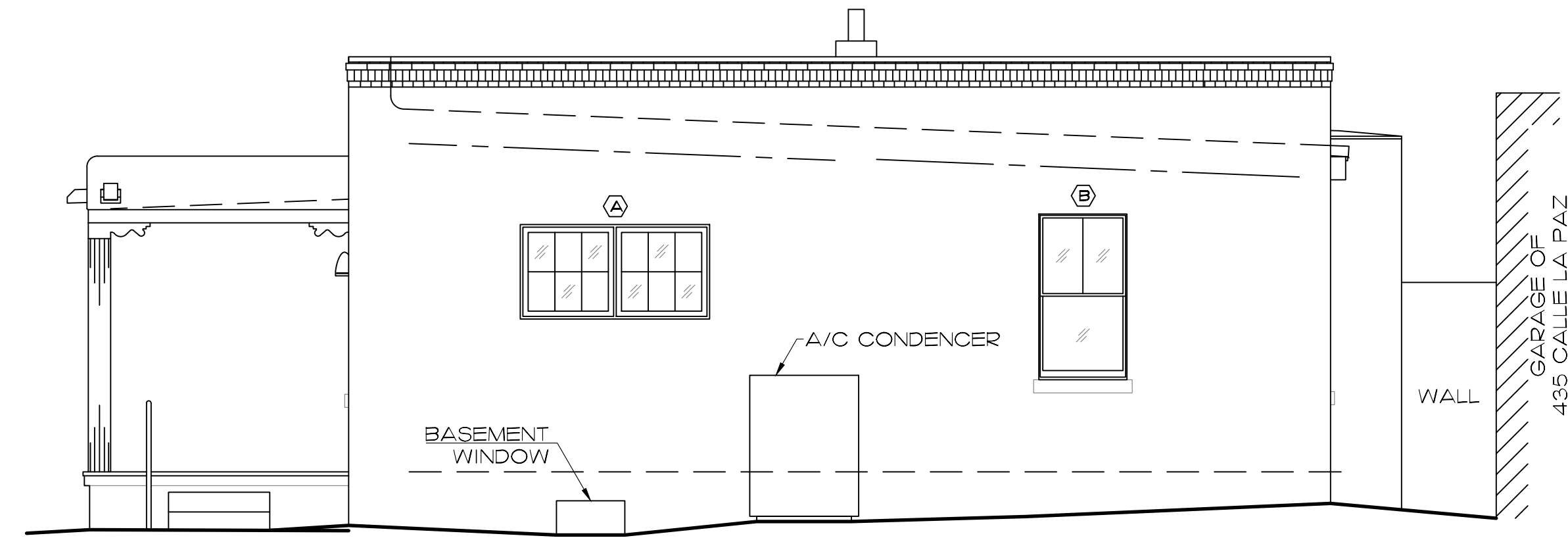

1 EXISTING WEST ELEVATION
A-4.1 SCALE: 1/4" = 1'-0"

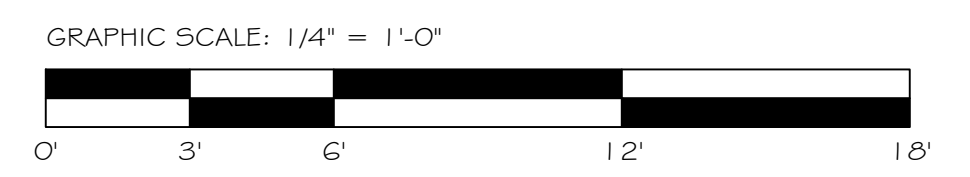

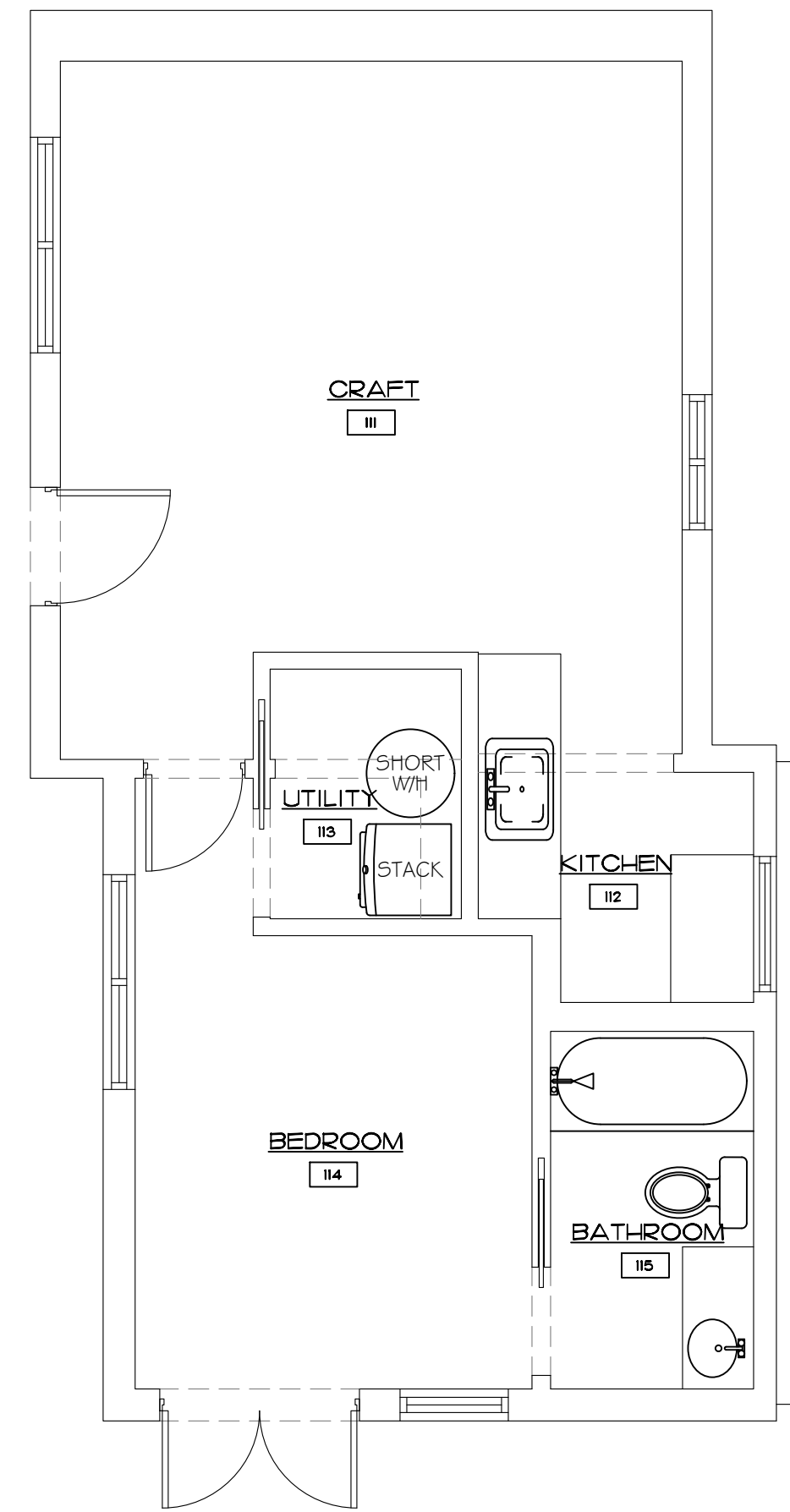

1 CASITA - EXISTING FLOOR PLAN
A-5.0 SCALE: 1/4" = 1'-0"

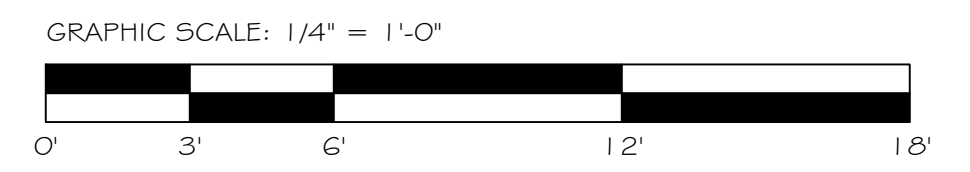

MARTINEZ
ARCHITECTURE
STUDIO PC
1524 PASEO DE PERALTA SANTA FE
505.989.4958 studio@martinezarch.com

RENOVATION
433 CALLE LA PAZ
SANTA FE,
NEW MEXICO

JULY 3, 2025

CASITA -
EXISTING
FLOOR PLAN

A
5.0

SET #
AUSTIN-GREGORY - 2509

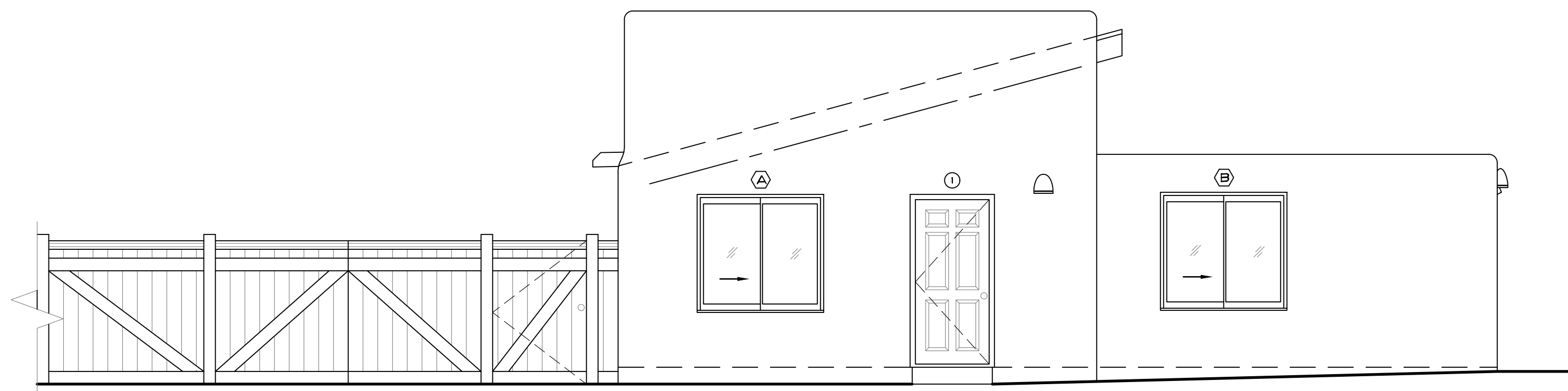

2 EXISTING WEST ELEVATION
A-6.0 SCALE: 1/4" = 1'-0"

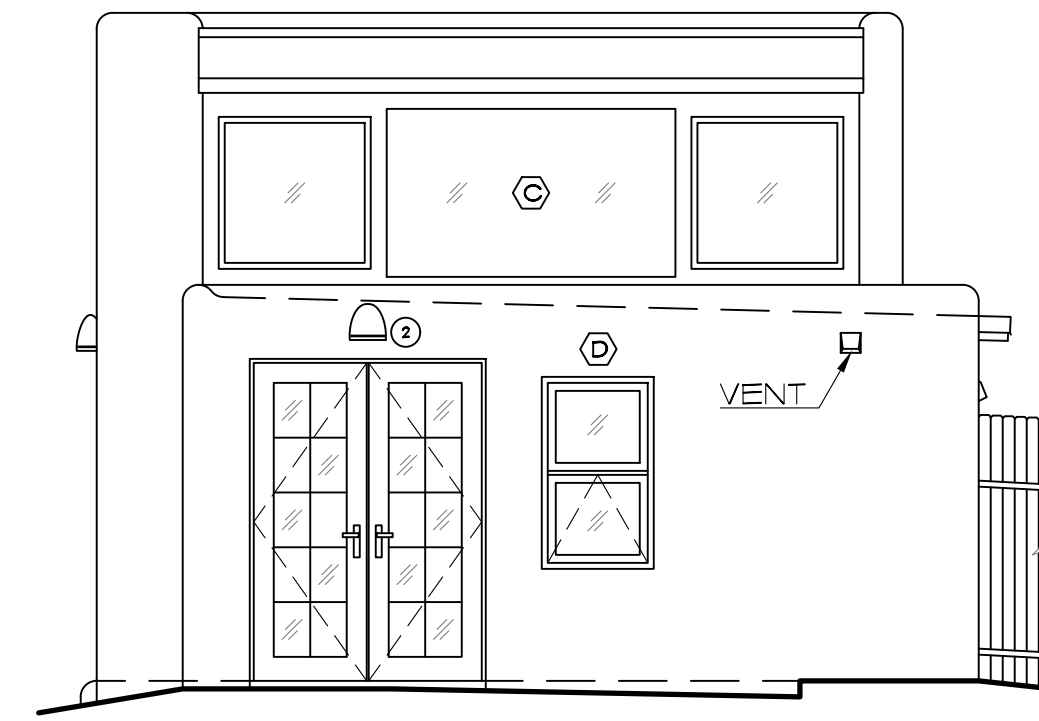

1 EXISTING SOUTH ELEVATION
A-6.0 SCALE: 1/4" = 1'-0"

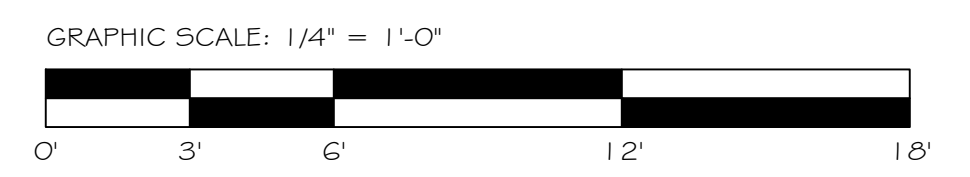

MARTINEZ
ARCHITECTURE
STUDIO PC
1524 PASEO DE PERALTA SANTA FE
505.989.4958 studio@martinezarch.com

RENOVATION
433 CALLE LA PAZ
SAN TAFE,
NEW MEXICO

JULY 3, 2025

CASITA -
WEST &
SOUTH
ELEVATIONS

A
6.0

SET #
AUSTIN-GREGORY - 2509

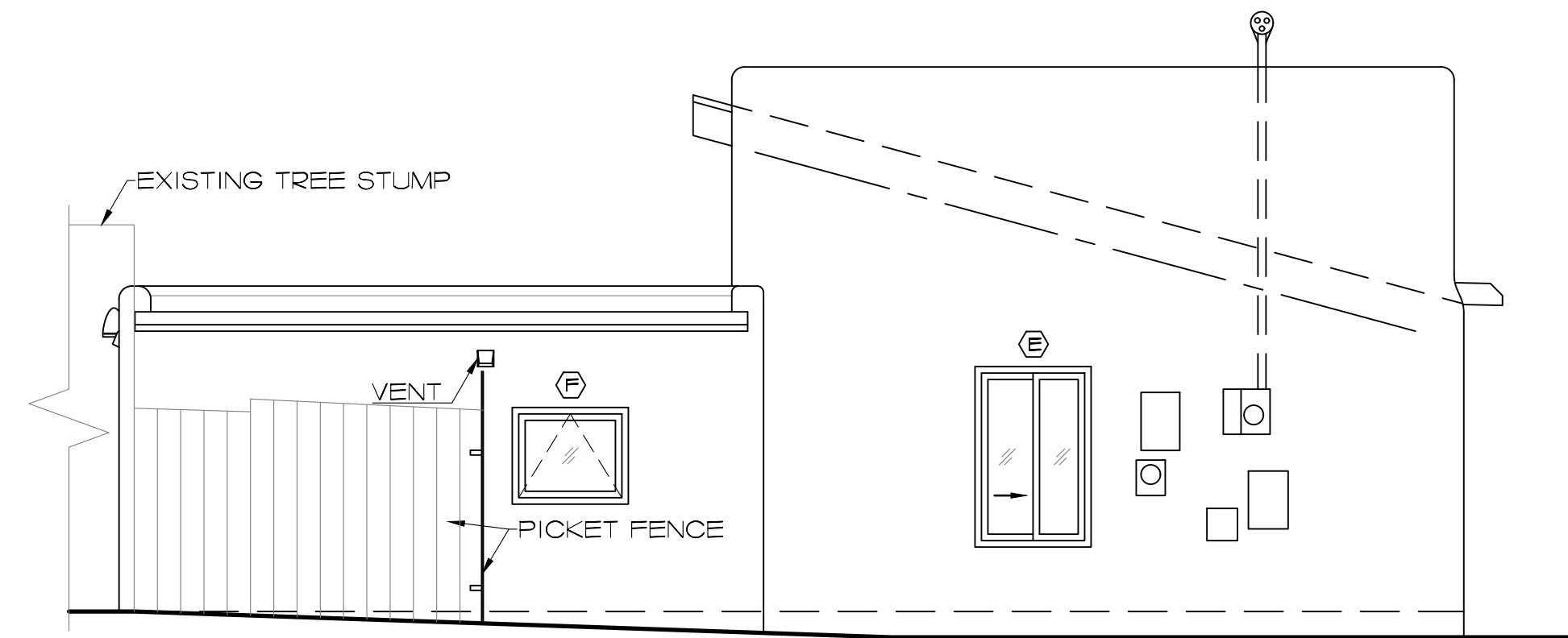

2 EXISTING EAST ELEVATION
A-6.1 SCALE: 1/4" = 1'-0"

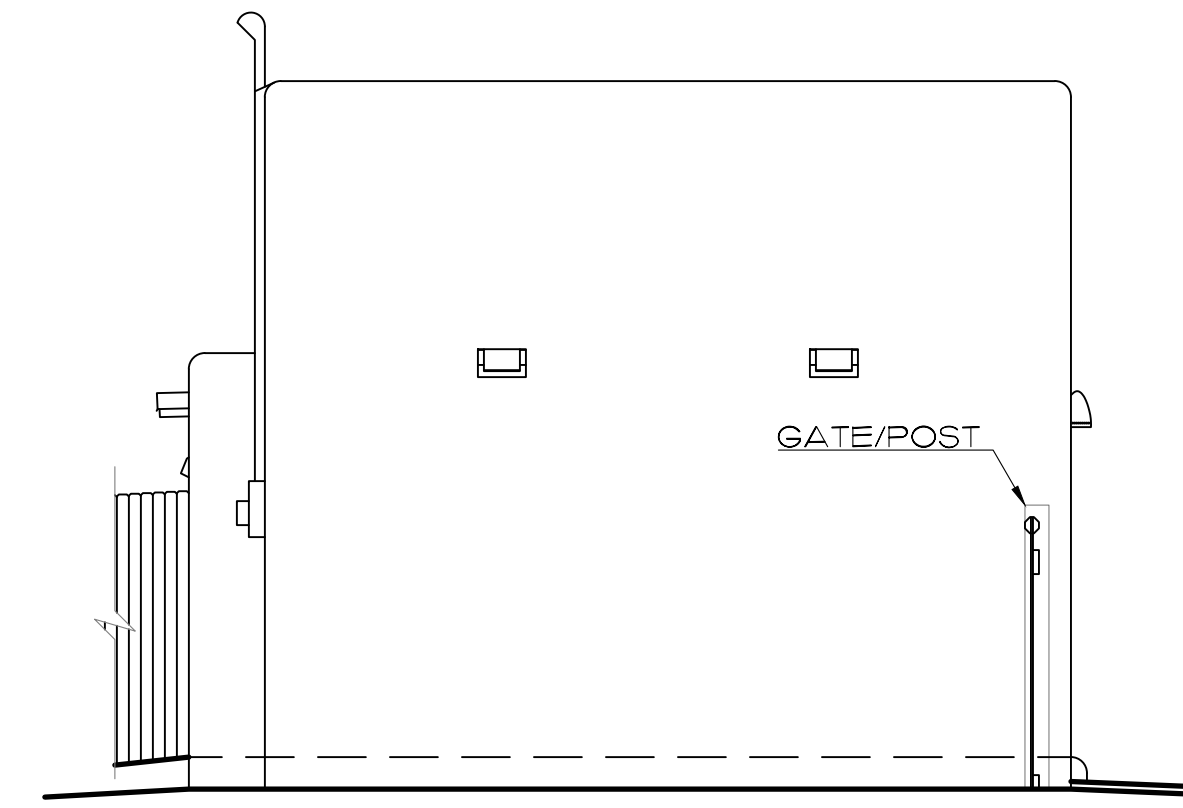

1 EXISTING NORTH ELEVATION
A-6.1 SCALE: 1/4" = 1'-0"

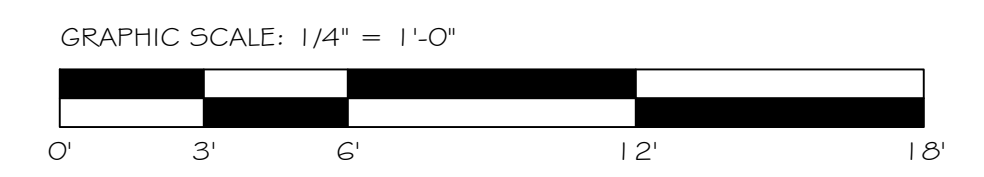

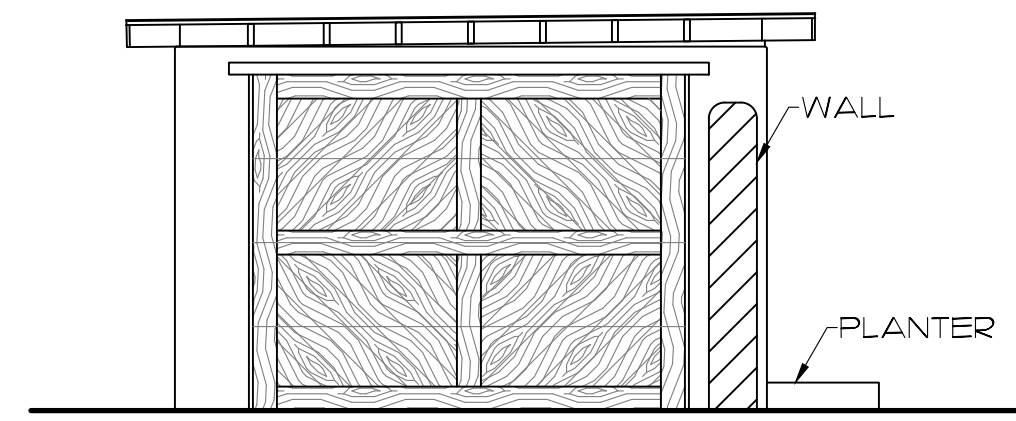

1 EXISTING WEST ELEVATION
A-6.2 SCALE: 1/4" = 1'-0"

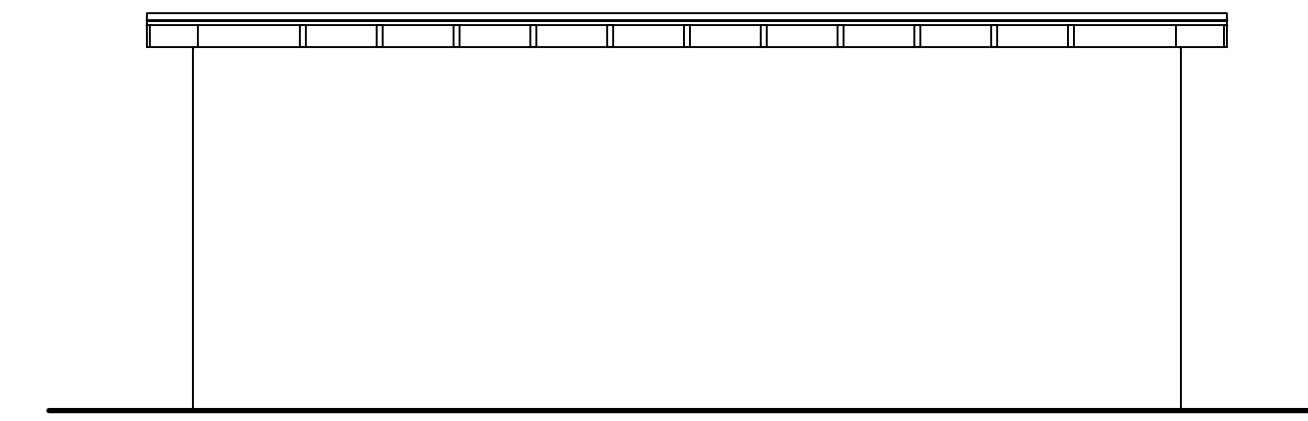

2 EXISTING NORTH ELEVATION
A-6.2 SCALE: 1/4" = 1'-0"

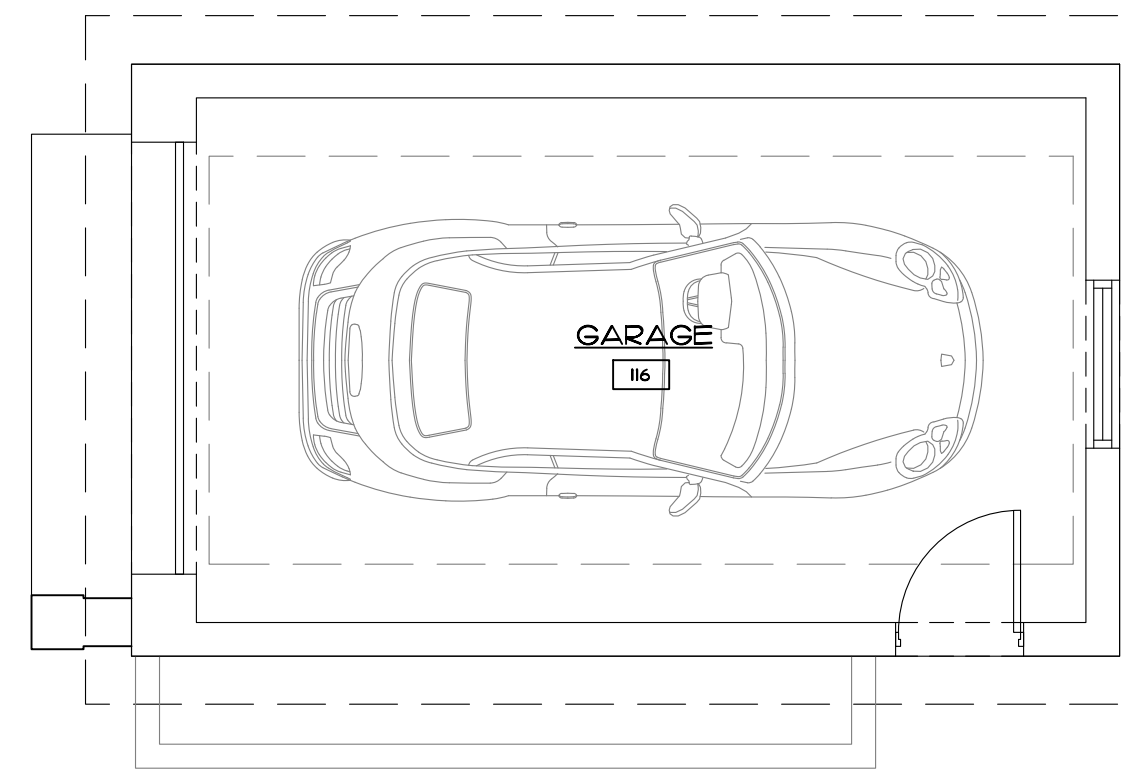

5 EXISTING FLOOR PLAN
A-6.2 SCALE: 1/4" = 1'-0"

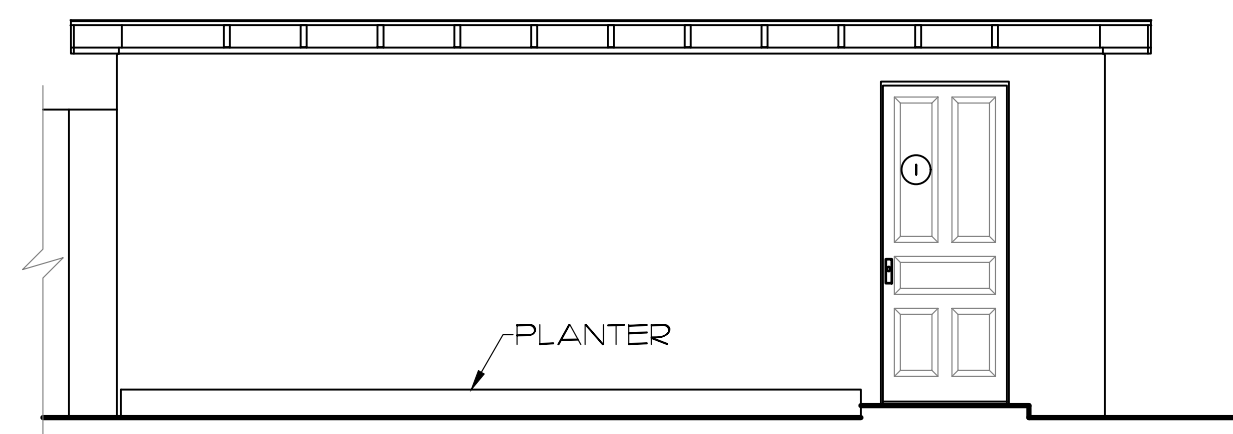

3 EXISTING SOUTH ELEVATION
A-6.2 SCALE: 1/4" = 1'-0"

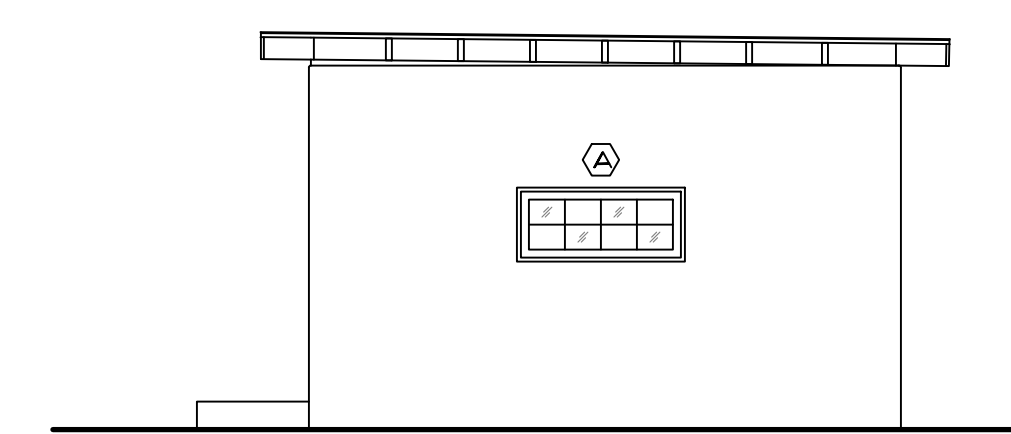

4 EXISTING EAST ELEVATION
A-6.2 SCALE: 1/4" = 1'-0"

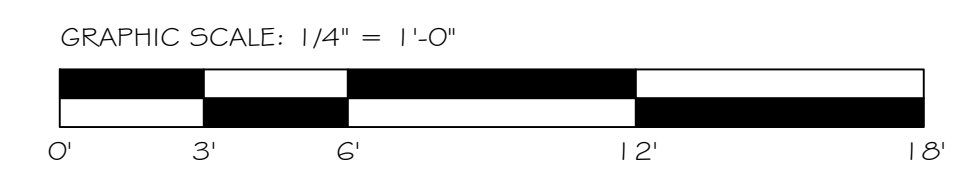

MARTINEZ
ARCHITECTURE
STUDIO PC
1524 PASEO DE PERALTA SANTA FE
505.989.4958 studio@martinezarch.com

RENOVATION
433 CALLE LA PAZ
SANTA ANITA FEE,
NEW MEXICO

JULY 3, 2025

GARAGE
FLOOR AND
ELEVATIONS
- NO
CHANGES
PROPOSED

A
6.2

SET #

AUSTIN-GREGORY - 2509