



**Date:** October 7, 2024

**To:** Mayor Alan Webber and Governing Body  
Finance Committee  
Quality of Life Committee

**Via:** Brian Moya, Fire Chief

**From:** Daniel Garcia, Fleet Section Manager

**Subject:** Purchase of BME Type 3; Model 34 Commercial Wildland Vehicle

**Vendor Name:** Siddons Fire Apparatus

**Vendor Number:** 3592

**ITEM AND ISSUE:**

Santa Fe Fire Department respectfully requests your review and approval of the purchase request of a BME, Type 3; Model 34 Commercial Wildland Vehicle in the total amount of \$486,350.00 – not to exceed for the prevention of Urban Interface Wildland Fires and provide more availability of units for a quicker response. (Siddons Fire Apparatus / Fire Department); (Daniel Garcia, Fire Fleet Manager, [dagarcia@santafenm.gov](mailto:dagarcia@santafenm.gov), and (505) 231-8561; Brian Moya, Fire Chief, [bjmoya@santafenm.gov](mailto:bjmoya@santafenm.gov), and (505) 955-3111.)

**Action Requested:** Approval of purchase

**BACKGROUND AND SUMMARY:**

The purchase of a BME Type 3; Model 34 Commercial Wildland Vehicle is essential for the prevention and mitigation of urban interface wildland fires, as well as to enhance the availability of units for faster response times. This Type 3 Wildland Fire Engine Pumper is specifically designed to navigate challenging environments that our main engines may not be able to access, such as narrow roads or mountainous terrain. By acquiring this unit, we will increase our department's capacity to respond to wildland fire threats in areas with restricted access, ensuring better protection for all districts within the city.

**PROCUREMENT METHOD:**

Small Purchase utilizing Cooperative Agreement.

The procurement method is the Cooperative Agreement HGACBuy #FS12-23 which expires on November 30, 2027.

**Chief Procurement Officer Approval:**  **Date:** 10/29/2024  
**Comment/Exceptions:** \_\_\_\_\_

**Supporting Information:**



**CONTRACT NUMBER:**

The FY25 Munis contract number is 3250240

**SOURCE/REVENUE:** Expense Revenue

The funding source is:

**Fund Name/Number:** General Fund/Fund 100

**Munis Org Name/Number:** FIRMedSvcs / 1000186

**Munis Object Name/Number:** Vhcl < 1.5 / 570950

**If the project is grant funded? Last grant award number:** N/A

**Grant Manager / Accounting Officer Approval:** \_\_\_\_\_ **Date:** \_\_\_\_\_

**Comment/Exceptions:** \_\_\_\_\_

**Project Ledger #:** \_\_\_\_\_

**Budget Officer Approval:** Andy Hopkins **Date:** 10/22/2024

**Comment/Exceptions:** \_\_\_\_\_

**CAPITAL ASSET (will this procurement result in a tangible item that costs more than \$5,000?):**

Yes |  No

**# (if known):** \_\_\_\_\_

**Repair or Replacement of Existing Equipment:**

Yes |  No

If yes -> Repair |  Replacement

**Please explain:** \_\_\_\_\_

**Capital Project:**

(New and improvement projects that are going to cost \$10,000 or more)

Yes |  No

**Project Ledger #:** \_\_\_\_\_

**Anticipated length of project:** \_\_\_\_\_

**Asset Manager Approval:** Lisa Storey **Date:** 10/29/2024

**Comment/Exceptions:** Fire truck will be capitalized as will outfitting associated with vehicle.

**Department Approvals:**

IT Components:  Yes |  No



Vehicles:  Yes |  No

Facilities, Furniture, Fixtures, Equipment:  Yes |  No

Approval: Daniel Garcia Title: Fire Fleet Manager Date: 09-05-2024

Approval: *Emily K. Carter* Title: Finance Director Date: 10/30/2024

Comment & Exceptions: \_\_\_\_\_

Department Contract Administrator Contact Info:

Victoria Velarde,

Business Operations Manager

Santa Fe Fire Department

Office: (505) 955-3113

Cell: (505) 629-5500

**ATTACHMENTS:**

*Keep only those that pertain and delete the rest (including this message)*

Vendor's Quote

Certificate of Liability Insurance

Professional/General Services Contract





# **FIRE TRUCKS**

***3892 STOCK UNIT  
MODEL 34 "TARGHEE"***



### **DETERMINATION OF APPARATUS WEIGHT**

BME Fire Trucks, LLC. shall submit estimated "in-service" weight analysis required by applicable NFPA standards. This Excel computer weight analysis shall break down all major components of the apparatus and shall show the impact on percentage-of-load on the front and rear axles, total weight, and weight on each tire set.

The analysis shall evenly distribute the NFPA required minimum payload allowance or estimated equipment payload as provided by the purchaser into the specified compartments. The allowance for personnel, hose loads, water and foam fluids, and required NFPA equipment shall be outlined individually in the analysis and placed on the apparatus in its specific intended position.

### **CENTER-OF-GRAVITY ANALYSIS**

BME Fire Trucks, LLC. shall perform an estimated center of gravity calculation as required by the applicable section of NFPA standards. This calculation shall include tilt angles, the estimated right to left load distribution, and load on each axle, including all specified major components.

### **LOW VOLTAGE TEST REQUIRMENTS**

The fire apparatus low voltage electrical system shall be tested as required by this section and the test results shall be certified by the apparatus manufacturer. The certification shall be delivered to the purchaser with the documentation for the completed apparatus. The tests shall be performed when the air temperature is between 0 degrees Fahrenheit and 110 degrees Fahrenheit.

### **TEST SEQUENCE**

The three tests defined below shall be performed in the order in which they appear. Before each test, the chassis batteries shall be fully charged until the voltage stabilizes at the voltage regulator set point and the lowest charge current is maintained for 10 minutes. The failure of any of these tests shall require a repeat of the test sequence.

### **RESERVE CAPACITY TEST**

The chassis engine shall be started and kept running until the chassis engine and engine compartment temperatures are stabilized at normal operating temperatures and the chassis battery system is fully charged. The chassis engine shall be shut off and the minimum continuous electrical load shall be applied for 10 minutes. All electrical loads shall be turned off prior to attempting to restart the chassis engine. The chassis battery system shall then be capable of restarting the chassis engine. The failure to restart the chassis engine shall be considered a failure of this test.

### **ALTERNATOR PERFORMANCE TEST AT IDLE**

## Boise Mobile Equipment

The minimum continuous electrical load shall be applied with the chassis engine running at idle speed. The chassis engine temperature shall be stabilized at normal operating temperature. The chassis battery system shall be tested to detect the presence of a chassis battery current discharge. The detection of chassis battery current discharge shall be considered a failure of this test.

### **ALTERNATOR PERFORMANCE TEST AT FULL LOAD**

The total continuous electrical load shall be applied with the chassis engine running up to the engine manufacturer's governed speed. The test duration shall be a minimum of two hours. The activation of the electrical system load management system shall be permitted during this test. The activation of an alarm due to excessive chassis battery discharge, as detected by the system required by NFPA (current edition), or an electrical system voltage of less than 11.8 volts direct current for a 12 volt direct current nominal system, for more than 120 seconds, shall be considered a failure of this test.

### **LOW VOLTAGE ALARM TEST**

Following the completion of the tests described above, the chassis engine shall be turned off. With the chassis engine turned off, the total continuous electrical load shall be applied and shall continue to be applied until the excessive battery discharge alarm activates. The chassis battery voltage shall be measured at the battery terminals.

The test shall be considered to be a failure if the low voltage alarm has not yet sounded 140 seconds after the voltage drops to 11.70 volts direct current for a 12 volt direct current nominal system. The chassis battery system shall then be able to restart the chassis engine. The failure of the chassis battery system to restart the chassis engine shall be considered a failure of this test.

The completed fire apparatus shall undergo a complete 12 volt electrical load and performance testing per applicable sections of NFPA standards with inspection and test sheets included in delivery documentation.

### **DOCUMENTATION**

The apparatus manufacturer shall provide the results of the low-voltage electrical system performance test, certified in writing, with the documentation provided to the purchaser at the time of delivery of the completed apparatus.

The test results shall consist of the following documents:

- (1) Documentation of the electrical system performance tests.
- (2) A written electrical load analysis, including the following:
  - (a) The nameplate rating of the alternator.
  - (b) The alternator rating under the conditions specified in NFPA 1906 (current edition).

## Boise Mobile Equipment

- (c) Each of the component loads specified that make up the minimum continuous electrical load.
- (d) Additional electrical loads that, when added to the minimum continuous electrical load, determine the total continuous electrical load.
- (e) Each individual intermittent electrical load.

### **TEST RESULTS**

BME Fire Trucks LLC. shall provide results of the apparatus testing and shall certify the following:

The weight of the completed apparatus, when loaded to its estimated in service weight, does not exceed the GVWR and GAWR of the chassis.

The complete unit, when loaded to its estimated in service weight, meets the weight distribution and vehicle stability requirements, as defined in the current NFPA guidelines.

The unit meets all required federal standards pertaining to the manufacturer and completion of the apparatus and a label tag has been affixed to the apparatus by the manufacturer stating same.

BME Fire Trucks LLC. shall provide all testing results, including engine, speed, acceleration, road ability, braking, and auxiliary braking to the Purchaser at the time of delivery.

### **DELIVERY REQUIREMENTS**

The bidder shall not be responsible for delays in delivery due to strikes, acts of God, failure of suppliers to deliver, chassis shortage and other reasons beyond the reasonable control of the builder. Should BME Fire Trucks, LLC. be unable to comply with the proposed delivery date, we shall immediately contact the purchaser regarding delay information and actions to be taken by the company.

This vehicle shall be F.O.B. the BME Fire Trucks facility in Boise Idaho. Dealer shall be responsible for arrangement of delivery from factory.

### **GENERAL WARRANTY PROVISIONS**

All materials and workmanship herein specified, including all equipment furnished, shall be guaranteed for a period of one (1) year after the acceptance date of the apparatus, unless otherwise noted, with the exception of any normal maintenance services or adjustments which shall be required. Under this warranty, BME Fire Trucks, LLC. shall be responsible for the costs of repairs to the apparatus that have been caused by defective workmanship or materials during this period.

This warranty shall not apply to the following:

- Any component parts or trade accessories such as chassis, engines, tires, pumps, valves, signaling devices, batteries, electric lights, bulbs, alternators, and all other installed equipment and accessories, in as much as they are usually warranted separately by their respective manufacturers, or are subject to

07/03/24

## Boise Mobile Equipment

normal wear and tear.

- Failures resulting from the apparatus being operated in a manner or for a purpose not recommended by the apparatus manufacturer.
- Loss of time or use of the apparatus, inconvenience or other incidental expenses.
- Any apparatus which has been repaired or altered without written consent or outside of the apparatus manufacturer's factory and or authorized service center in any way that affects its stability, or which has been subject to misuse, negligence, or accident.
- Delivery of the apparatus to repair site.

### **DISCLAIMER**

NO WARRANTIES ARE GIVEN BEYOND THOSE DESCRIBED HEREIN. THIS WARRANTY IS IN LIEU OF ALL OTHER WARRANTIES, EXPRESSED OR IMPLIED. THE COMPANY SPECIFICALLY DISCLAIMS WARRANTIES OF MERCHANTABILITY AND FITNESS FOR A PARTICULAR PURPOSE, ALL OTHER REPRESENTATIONS TO THE USER/PURCHASER AND ALL OTHER OBLIGATIONS OR LIABILITIES. FURTHER, THE COMPANY EXCLUDES LIABILITY FOR CONSEQUENTIAL AND INCIDENTAL DAMAGES, ON THE PART OF THE COMPANY OR SELLER. No person is authorized to give any other warranties or to assume any liabilities on the Company's behalf unless made or assumed in writing by the seller; and no other person is authorized to give any warranties or to assume any liabilities on the seller's behalf unless made or assumed in writing by the seller.

### **OBTAINING SERVICE**

Return the vehicle to any BME Fire Trucks, LLC. dealer/authorized service center; Return the vehicle to BME Fire Trucks, LLC. or contact BME Fire Trucks, LLC.. BME Fire Trucks, LLC. shall be solely responsible for determining the extent of repair under the terms of the warranty. Transportation costs shall be the responsibility of the purchaser.

### **MATERIAL AND WORKMANSHIP**

All equipment provided shall be guaranteed to be new and of current manufacture, and unless specified otherwise, shall meet all requirements of these specifications and prevailing NFPA documents and be in condition at time of delivery for use as specified for this type of apparatus.

All workmanship shall be of the highest quality and accomplished in a professional manner so as to insure a functional apparatus with a high quality aesthetic appearance.

07/03/24

## Boise Mobile Equipment

The construction shall be rugged and ample safety factors shall be provided to carry the loads specified to meet both on and off road requirements.

The apparatus shall be designed and the equipment mounted with due consideration to the distribution of load between the front and rear axles, so all specified equipment, with a full complement of personnel, can be carried without damage to the apparatus.

### **BODY AND STRUCTURAL WARRANTY**

BME Fire Trucks, LLC. shall warrant each new apparatus body, if used in a normal and reasonable manner, against structural defects caused by defects in material, design or workmanship for a period of ten (10) years, covering parts & labor to the original purchaser which shall start on day of acceptance.

This warranty shall not apply to:

- Normal maintenance services or adjustments
- To any vehicle which will have been repaired or altered outside of our factory in any way so as, in the judgment of BME Fire Trucks, LLC., to affect it's stability, nor which has been subject to misuse, negligence, or accident, nor to any vehicle made by us which will have been operated to a speed exceeding the factory rated speed, or loaded beyond the factory rated load capacity.
- Commercial chassis and associated equipment furnished with chassis, signaling devices, generators, batteries, or other trade accessories as they are usually warranted separately by their respective manufacturers.
- Shipping costs of parts or apparatus for purposes of repair or replacement of parts. This warranty is in lieu of all other warranties, expressed or implied. All other representations as to the original purchaser and all other obligations or liabilities, including for incidental or consequential damage on the company's behalf unless made in writing by the company.

### **DARLEY FIRE PUMP WARRANTY**

A three (3) year warranty on the Darley fire pump shall be provided. The provisions of this warranty shall be described in the completed apparatus documentation.

### **PLUMBING WARRANTY**

The stainless steel fire pump plumbing shall carry a ten (10) year parts and labor warranty against defects in workmanship and perforation corrosion.

### **AKRON VALVE WARRANTY**

07/03/24

## Boise Mobile Equipment

The Akron valves shall carry a ten (10) year parts and labor manufacturer's warranty. Provisions of this warranty shall be provided with the completed apparatus documentation.

### **FOAM TANK WARRANTY**

The foam tank shall carry a "lifetime" warranty against defects in workmanship and perforation corrosion. The provisions of this warranty shall be provided in the delivery documentation. The tank manufacturer shall repair, at no cost to the purchaser, any problems caused by defective materials and/or workmanship. The warranty shall cover the reasonable costs of removing the water tank from the apparatus and reinstalling it after the completion of the covered warranty repairs, but shall not cover any liability for the loss of service or downtime costs of the apparatus.

### **WATER TANK WARRANTY**

The polypropylene water tank that is specified to be supplied with this apparatus shall be warranted by the water tank manufacturer for a "lifetime" period from the date that the apparatus is put into service. The tank manufacturer shall repair, at no cost to the purchaser, any problems caused by defective materials and/or workmanship. The warranty shall cover the reasonable costs of removing the water tank from the apparatus and reinstalling it after the completion of the covered warranty repairs, but shall not cover any liability for the loss of service or downtime costs of the apparatus.

### **PAINT WARRANTY**

BME Fire Trucks, LLC. shall provide a seven (7) year paint warranty which shall cover peeling and/or de-lamination of the top coat and other layers of paint, cracking or checking, loss of gloss caused by cracking, checking or chalking, and any paint failure caused by defective paint materials covered by the paint manufacturer's material warranty.

### **CHASSIS WARRANTY**

The specified chassis shall be provided with the chassis manufacturer's warranty. The exact provisions of this warranty shall be supplied with the completed apparatus documentation.

### **APPARATUS OPERATION MANUAL(S)**

BME Fire Trucks, LLC. shall provide (2) electronic apparatus operational manual(s) on a USB thumb drive.

### **CHASSIS SPECIFICATION**

#### **Vehicle configuration**

## Boise Mobile Equipment

M2 106 plus conventional chassis

2024 model year specified

Set back axle - truck

Straight truck provision, non-towing

Lh primary steering location

### **General service**

Truck configuration

Domiciled, usa 50 states (including california and carb opt-in states)

Fire service

Emergency vehicles business segment

Liquid bulk commodity

Terrain/duty: 10% (some) of the time, in transit, is spent on non-paved roads

Maximum 8% expected grade

Maintained gravel or crushed rock - most severe in-transit (between sites) road surface

Medium truck warranty

Expected front axle(s) load : 14000.0 lbs

Expected rear drive axle(s) load : 25000.0 lbs

Expected gross vehicle weight capacity : 39000.0 lbs

### **Engine**

Cum I9 360ev hp @ 2200 rpm, 2200 gov rpm, 1150 lb-ft @ 1200 rpm, r/f/e

### **Engine equipment**

2010 epa/carb/ghg21 configuration

2008 carb emission cert - clean idle (w/6x4 inch label shipped loose w/installation instructions) installed by final stage mfr on driver door or lh side hood

Oil pan for awd and awd conversions

Engine mounted oil check and fill

## Boise Mobile Equipment

Side of hood air intake with nfpa compliant ember screen and fire retardant donaldson air cleaner

Ln 12v 320 amp 4962pgh pad mount alternator

(3) dtna genuine, flooded starting, min 2850cca, 525rc, threaded stud batteries

Standard battery jumpers

Wire ground return for battery cables with additional frame ground return

Non-polished battery box cover

Positive load disconnect with cab mounted control switch with locking provision mounted outboard driver seat

Cummins turbocharged 18.7 cfm air compressor with internal safety valve

Standard mechanical air compressor governor

Air compressor discharge line

Gvg, fire and emergency service vehicles engine warning

C-brake by jacobs with high med low brake with brake lamps

Rh outboard under step mounted horizontal aftertreatment system assembly with rh horizontal tailpipe

Engine aftertreatment device, automatic over the road active regeneration and virtual regeneration request switch in cluster and dash mounted inhibit switch

Standard exhaust system length

Rh standard horizontal tailpipe

6 gallon diesel exhaust fluid tank

100 percent diesel exhaust fluid fill

Lh under cab diesel exhaust fluid tank

Inboard mounted diesel exhaust fluid pump with above rail routing for 6 gallon diesel exhaust fluid tank, cummins engines

Standard diesel exhaust fluid tank cap

Horton 2-speed drivemaster advantage polarextreme fan drive

Automatic fan control with dash switch and indicator light, non engine mounted

Cummins spin on fuel filter

## Boise Mobile Equipment

Combination full flow/bypass oil filter

1100 square inch aluminum radiator

Antifreeze to -60f, ethylene glycol pre-charged sca heavy duty coolant

Gates blue stripe coolant hoses or equivalent

Constant tension hose clamps for coolant hoses

Auxiliary engine cooling using water from fire pump

Aluminum flywheel housing

Electric grid air intake warmer

Delco 12v 39mt hd/ocp starter with thermal protection and integrated magnetic switch

### Transmission

Allison 3000 evs automatic transmission with pto provision

### Transmission equipment

Allison vocational package 265 - available on 3000/4000 product families with vocational model evs

Allison vocational rating for fire truck/emergency vehicle applications available with all product families

Primary mode gears, lowest gear 1, start gear 1, highest gear 6, available for 3000/4000 product families only

Secondary mode gears, lowest gear 1, start gear 1, highest gear 6, available for 3000/4000 product families only

Primary shift schedule recommended by dtna and allison, this defined by engine and vocational usage

Secondary shift schedule recommended by dtna and allison, this defined by engine and vocational usage

Primary shift speed recommended by dtna and allison, this defined by engine and vocational usage

Secondary shift speed recommended by dtna and allison, this defined by engine and vocational usage

Engine brake range preselect recommended by dtna and allison, this defined by engine and vocational usage

Engine brake range alternate preselect recommended by dtna and allison, this defined by engine and vocational usage

Fuel sense 2.0 disabled - performance - table based

Driver switch input - default - no switches

Electronic transmission wiring to customer interface connector

## Boise Mobile Equipment

Customer installed chelsea 280 series pto

Pto mounting, lh side of main transmission allison

Magnetic plugs, engine drain, transmission drain, axle(s) fill and drain

Push button electronic shift control, dash mounted

Transmission prognostics - enabled 2013

Water to oil transmission cooler, in radiator end tank

Meritor mtc-4210 and mtc-4213 transfer case oil cooler

Transmission oil check and fill with electronic oil level check

Meritor mtc 4210xl-ec 2-speed transfer case

Transfer case shift controls in dash

Synthetic transmission fluid (tes-295 compliant)

### Front axle and equipment

Mx-14-120-evo 14,000# 1790mm kpi single front drive axle

4.88 front axle ratio

Mxl 16t meritor extended lube front steering axle driveline with half round yokes

Meritor 16.5x5 q+ mx drive axle cast spider heavy duty cam front brakes

Fire and emergency severe service, non-asbestos front lining

Meritor cast iron front brake drums

Front brake dust shields

Front oil seals

Standard spindle nuts for all axles

Meritor automatic front slack adjusters

Trw tas-85 power steering

Power steering pump

2 quart see through power steering reservoir

## Boise Mobile Equipment

Current available synthetic 75w-90 front axle lube

### **Front suspension**

14,600# taperleaf front suspension

Maintenance free rubber bushings - front suspension

Front shock absorbers

### **Rear axle and equipment**

Rs-25-160 27,000# r-series fire/emergency service single rear axle

4.89 rear axle ratio

Iron rear axle carrier with standard axle housing

Mxl 17t meritor extended lube main driveline with half round yokes

Mxl 17t meritor extended lube intertransmission driveline with half round yokes

Driver controlled traction differential - single rear axle

(1) driver controlled differential lock rear valve for single drive axle

Indicator light for each differential lockout switch, engage at speeds 5 mph or less, disengage w/ign off or speeds exceeding 25 mph

Meritor 16.5x7 p cast spider cam rear brakes, double anchor, cast shoes

Fire and emergency severe service non-asbestos rear brake lining

Brake cams and chambers on forward side of drive axle(s)

Webb heavy weight cast iron rear brake drums

Rear oil seals

Wabco tristop d longstroke 1-drive axle spring parking chambers

Haldex automatic rear slack adjusters

Current available synthetic 75w-90 rear axle lube

### **Rear suspension**

27,000# flat leaf spring rear suspension with helper and radius rod for fire/emergency service

Spring suspension - no axle spacers

## Boise Mobile Equipment

Standard axle seats in axle clamp group

Fore/aft control rods

### **Brake system**

Air brake package

Wabco 4s/4m abs with traction control

Reinforced nylon, fabric braid and wire braid chassis air lines

Fiber braid parking brake hose

Standard brake system valves

Standard air system pressure protection and 85 psi pressure protection for air horn(s)

Std u.s. Front brake valve

Relay valve with 5-8 psi crack pressure, no rear proportioning valve

Bw ad-9si brake line air dryer with heater

Air dryer mounted outboard on lh rail

Steel air brake reservoirs mounted inside rail; customer accepts tanks mounted in rear overhang/rear suspension mount over rear axle only, if additional tanks are required mount in overhang

Pull cable on wet tank, petcock drain valves on all other air tanks

### **Wheelbase & frame**

4500mm (177 inch) wheelbase

11/32x3-1/2x10-15/16 inch steel frame (8.73mmx277.8mm/0.344x10.94 inch) 120ksi

1600mm (63 inch) rear frame overhang

Frame overhang range: 61 inch to 70 inch

8 inch bolt on front frame extension

Calc'd back of cab to rear susp c/l (ca): 64.37 in

Calculated effective back of cab to rear suspension c/l (ca): 59.87 in

Calc'd frame length - overall : 269.55 in

Calculated frame space lh side : 41.3 in

## **Boise Mobile Equipment**

Calculated frame space rh side : 10.27 in

Square end of frame

Front closing crossmember

Standard weight engine crossmember

Standard crossmember back of transmission

Standard midship #1 crossmember(s)

Standard rearmost crossmember

Standard suspension crossmember

### **Chassis equipment**

Fender and front of hood mounted front mudflaps

Grade 8 threaded hex headed frame fasteners

D15-28195-000 center punch to mark centerline of rear suspension on top flange of frame

### **Fuel tanks**

70 gallon/264 liter aluminum fuel tank - lh

23 inch diameter fuel tank(s)

Plain aluminum fuel tank

Fuel tank(s) forward

Chrome fuel tank cap(s)

Detroit fuel/water separator with water in fuel sensor and 12 volt preheater

Equiflo inboard fuel system

Auxiliary fuel supply and return ports located on lh fuel tank

High temperature reinforced nylon fuel line

### **Tires**

Michelin xdn2 12r22.5 16 ply radial front tires

Michelin xdn2 12r22.5 16 ply radial rear tires

## Boise Mobile Equipment

### Hubs

Meritor iron front hubs

Conmet preset plus premium iron rear hubs

### Wheels

Alcoa 8x 22.5x8.25 10-hub pilot 5.81 inset aluminum disc front wheels

Alcoa 8x 22.5x8.25 10-hub pilot aluminum disc rear wheels

Front wheel mounting nuts

Rear wheel mounting nuts

### Cab exterior

8154 inch bbc high-roof aluminum conventional crew cab

Air cab mounting

Cab roof reinforcements for roof mounted components

2-1/2 inch fender extensions

Lh and rh exterior grab handles with single rubber insert

Hood mounted chromed plastic grille

Chrome hood mounted air intake grille

Fiberglass hood

Cab floor, toe board and firewall heat shield

Valve and plumbing for customer furnished air horn, piping capped at firewall

Dual electric horns

Rear license plate mount end of frame

Integral headlights with chrome bezels

Aerodynamic marker lights

Daytime running lights

Truck-lite 3 chamber modules with 45 series sealed beam lamps

## Boise Mobile Equipment

Standard front turn signal lamps

Dual west coast bright finish heated mirrors

Door mounted mirrors

102 inch equipment width

Lh and rh 8 inch bright finish convex mirrors mounted under primary mirrors

Rh and lh electric powered windows

1-piece solar green glass windshield

2 gallon windshield washer reservoir with fluid level indicator, frame mounted

### **Cab interior**

Rugged trim package

Gray & carbon vinyl interior "rugged"

Carbon with premium gunmetal accent (rugged)

Molded plastic door panel

Forward roof mounted console

Lh and rh door storage pockets integrated into molded door panels

Digital alarm clock in driver display

M2/sd dash

Heater, defroster and air conditioner

Standard hvac ducting

Main hvac controls with recirculation switch

Standard heater plumbing

Valeo heavy duty a/c refrigerant compressor

Binary control, r-134a

Premium insulation

Solid-state circuit protection and fuses

## Boise Mobile Equipment

12v negative ground electrical system

Premium cab lighting

Door locks and ignition switch keyed the same

Lh and rh electric door locks

Lh and rh integral door panel armrests

High visibility orange seat belts with driver indicator light and audible alarm

Adjustable tilt and telescoping steering column

4-spoke 18 inch (450mm) black steering wheel with switches

Seating shall be OEM. Front buckets and rear bench

Driver and passenger interior sun visors

### **Instruments & controls**

Digital panel lamp dimmer switch in driver display

Configurable lower panel with integrated upper storage

Engine remote interface without interlocks

Bright argent finish gauge bezels

Low air pressure indicator light and audible alarm with (1) additional park switch for customer use

(1) single brake application air gauge

Dual needle primary and secondary air pressure gauge

Dash mounted air restriction indicator with graduations

Electronic cruise control with controls on steering wheel spokes

Key operated ignition switch and integral start position; 4 position off/run/start/accessory

Premium instrument cluster with 5.0 inch tft color display

Heavy duty onboard diagnostics interface connector located below lh dash

2 inch electric fuel gauge

Engine remote interface for remote throttle

## Boise Mobile Equipment

Quickfit powertrain interface connector under cab with bluntcuts

Quickfit programmable interface connector(s) under cab with bluntcuts

Engine remote interface connector at powertrain interface connector

Electrical engine coolant temperature gauge

2 inch transmission oil temperature gauge

Electronic outside temperature sensor display in driver message center

Engine and trip hour meters integral within driver display

Pto controls for enhanced vehicle electric/electronic architecture

Electric engine oil pressure gauge

No overhead instrument panel

Quickfit programmable interface module + (4) 20 amp fused relays

Am/fm/wb world tuner radio with auxiliary input, j1939

Dash mounted radio

(2) radio speakers in cab

Multi-band am/fm/wb/cb lh mirror mounted antenna system

Standard radio wiring with steering wheel controls

Electronic mph speedometer with secondary kph scale, without odometer

Standard vehicle speed sensor

Electronic 3000 rpm tachometer

Detroit connect platform hardware

Ignition switch controlled engine stop

Digital voltage display integral with driver display

Single electric windshield wiper motor with delay

Rotary headlamp switch, marker lights/headlights switch with pull out for optional fog/road lamps

One valve parking brake system with warning indicator

## Boise Mobile Equipment

Self canceling turn signal switch with dimmer, headlamp flash, wash/wipe/intermittent

2 integral electronic turn signal flasher with 40 amp (20 amp per side) trailer lamp capacity

### **Design**

Paint: one solid color

### **Color**

Cab color a: "97902EY" Candy Apple Red

Black, high solids polyurethane chassis paint

### **CAB SEATING AND WEIGHT ALLOWANCE**

A warning label shall be installed in the cab to indicate seating positions.

### **LABELS, STANDARD PACKAGE SET**

A standard set of labels shall be provided and installed on the inside of chassis cab area. The labels shall contain the required information based on the applicable components for the apparatus.

### **DATA PLAQUE**

A data plaque shall be provided and installed on the inside of the driver's door. The data plaque shall contain the required information based on the applicable components for the apparatus:

- Engine oil
- Engine coolant
- Chassis transmission fluid
- Drive axle lubricant
- Power steering fluid
- Pump, generator, or other component lubrications
- Other NFPA applicable fluid levels or data as required
- Paint manufacturer, type, and color number
- Tire Speed Ratings

Location shall be in the driver's compartment or on the driver's door.

### **DATA PLAQUE**

A data plaque shall be provided and installed. The plaque shall contain the following information.

## Boise Mobile Equipment

- Pump make and model
- GPM capacity rating
- Truck serial and production number
- Pump performance (specific GPMs at rated pressures with engine RPM)
- Governed engine RPM
- Pump gear ratio

### **WARNING LABEL -- NO RIDING ON REAR**

A warning label stating: "WARNING: DO NOT RIDE ON REAR STEP WHILE VEHICLE IS IN MOTION. DEATH OR SERIOUS INJURY MAY RESULT" shall be installed on the rear of the apparatus. The label shall be applied to the vehicle at the rear step area. The label shall warn personnel that riding in or on these areas, while the vehicle is in motion, is prohibited.

### **WARNING LABEL -- SEAT BELT USAGE**

A warning label, stating: "WARNING CRASH HAZARD OCCUPANTS MUST BE SEATED AND BELTED WHEN VEHICLE IS IN MOTION..." shall be provided in the apparatus cab interior. This label shall be located so that it is visible from all seating positions.

### **LOUD NOISE WARNING LABEL**

A final stage manufacturer shall install "hearing loss" potential warning labels on the vehicle in any areas or fixed equipment that produces excessive noise levels. (Exhaust outlet, sirens and air horns shall not be required for such equipment.)

### **AIR FILTER EMBER PROTECTION SCREEN WARNING LABEL**

A warning label, stating: "THIS VEHICLE HAS AN AIR INTAKE EMBER SCREEN WHICH REQUIRES PERIODIC INSPECTION & CLEANING" shall be provided and installed in the apparatus cab interior.

### **FRESH AIR EMBER SEPARATOR WARNING LABEL**

A warning label, stating: "THIS APPARATUS IS EQUIPPED WITH A CAB FRESH AIR INTAKE EMBER PROTECTION SCREEN. ROUTINE INSPECTION IS REQUIRED." shall be provided and installed in the apparatus cab interior.

### **WARNING LABEL -- DO NOT WEAR HELMET**

A warning label, stating: "CAUTION: DO NOT WEAR HELMET WHILE SEATED" shall be provided in the apparatus cab interior. This label shall be located so that it is visible from all seating positions.

### **MANUFACTURER LOGO**

The apparatus shall include a BME logo plaque which shall be affixed at the rear of the apparatus.

The BME plaque shall feature white reflective material on the outside of the Maltese cross and red reflective material in the middle.

### **FRONT TOW PLATE**

A horizontal full frame width, 3/4-inch thick steel plate, center pull, front tow eye shall be furnished and installed through or below the front bumper. The tow eye plate shall be triangle shaped extended 6 inches beyond the front bumper with a 3-inch X 4-inch rectangle tow eye.

The tow eye shall be braced and gusseted to prevent frame rail or bumper damage and bolted to the front frame rail web.

The tow plate shall to be sprayed with black durabak.

### **FRONT RECEIVER**

There shall be one 2" receiver hitch on the front of the apparatus. The receiver shall be mounted off set as to prevent towing use.

### **REAR RECEIVER**

There shall be one 2" receiver hitch on the rear of the apparatus. The receiver shall be mounted off set as to prevent towing use.

### **REAR BUSTLE**

A single, frame mounted, 3-inch X 4-inch diameter, rear towing eye shall be provided. It shall be manufactured from 3/4-inch thick steel plate and bolted between the rear frame rail webs with SAE Grade 8 frame bolts and lock nuts.

The tow eye shall be braced and gusseted to prevent damage to the frame rails, bumper or apparatus body while being towed from various angles. Access to the tow eye shall be below the bumper and designed not to interfere with the required angle of departure. The bustle shall be painted job color.

### **FRONT FRAME EXTENSION**

The front frame rails shall be extended 16" ahead of the cab grill or fender area.

**BUMPER PLATFORM**

The front bumper extended frame rails shall feature an overlay constructed of .125 inch, 5052 grade, aluminum embossed diamond plate which shall offer space for mounting components necessary to the apparatus. The bumper extension shall measure approximately sixteen (16) inches from the cab to the front face of the extension and shall be approximately eight (8) inches in height.

**BUMPER**

There shall be an International 15 degree bumper installed on the apparatus.

**FRONT BUMPER COLOR**

The front bumper shall be painted job color.

**BUMPER SIDE WINGS**

The bumper shall have steel side wings.

**FRONT BUMPER WINGS COLOR**

The front bumper wings shall be painted job color.

**REPLACEMENT FRONT BUMPER**

The front bumper on the Freightliner shall be replaced with an International front bumper.

**DRIVERS SIDE -- FRONT BUMPER COMPARTMENT**

One (1) recessed hose storage compartment shall be installed in the drivers side of the bumper. The compartment shall be constructed of smooth aluminum. The floor of the compartment shall have drain holes provided.

**BUMPER COMPARTMENT NYLON HOLD DOWN STRAP**

One (1) nylon strap with a buckle shall be installed on the specified front bumper compartment. The nylon strap shall act as a hold down mechanism for the hose in the compartment.

The straps shall be black in color.

**BUMPER COMPARTMENT GRATING**

## Boise Mobile Equipment

The specified bumper compartment shall be fitted with removable interlocking vinyl Dri-Dek grating. This material shall be resistant to heat, cold, ultra-violet radiation, mechanical impacts, chemical actions and is corrosion resistant.

The specified Dri-Dek grating shall be black in color.

### **CENTER -- FRONT BUMPER COMPARTMENT**

One (1) recessed hose storage compartment shall be installed in the center front bumper. The compartment shall be constructed of smooth aluminum. The floor of the compartment shall have drain holes provided.

### **BUMPER COMPARTMENT DOOR**

An aluminum tread plate door shall be installed on the specified front bumper compartment. The non-skid surface door shall have a stainless steel hinge at the rear, latch, and hold open device installed.

The specified door(s) shall have a Polished stainless-steel D-ring door handle.

### **BUMPER COMPARTMENT GRATING**

The specified bumper compartment shall be fitted with removable interlocking vinyl Dri-Dek grating. This material shall be resistant to heat, cold, ultra-violet radiation, mechanical impacts, chemical actions and is corrosion resistant.

The specified Dri-Dek grating shall be black in color.

### **PASSENGER SIDE -- FRONT BUMPER COMPARTMENT**

One (1) recessed hose storage compartment shall be installed in the passenger side of the bumper. The compartment shall be constructed from smooth aluminum. The floor of the compartment shall have drain holes provided.

### **BUMPER COMPARTMENT NYLON HOLD DOWN STRAP**

One (1) nylon strap with a buckle shall be installed on the specified front bumper compartment. The nylon strap shall act as a hold down mechanism for the hose in the compartment.

The straps shall be black in color.

### **BUMPER COMPARTMENT GRATING**

## Boise Mobile Equipment

The specified bumper compartment shall be fitted with removable interlocking vinyl Dri-Dek grating. This material shall be resistant to heat, cold, ultra-violet radiation, mechanical impacts, chemical actions and is corrosion resistant.

The specified Dri-Dek grating shall be black in color.

### **BUMPER DISCHARGE SWIVEL STOPPER**

There shall be a swivel elbow stopper installed just behind the front discharge(s).

### **FRONT BUMPER BEZEL**

The center of the front bumper shall feature a bezel, the bezel shall trim out around the front tow plate and front Whelen Micro Pioneer lights and have an BME logo. The BME logo shall have reflective material behind it.

### **REFLECTIVE BACKGROUND**

Part shall feature a Red reflective background.

### **AIR HORN**

One (1) Buell brand, Model #1063 15" air horn shall be provided and mounted on the frame rail of the passenger's side frame, behind the bumper.

### **AIR HORN FOOT SWITCH**

One (1) foot switch shall be provided and installed. The foot switch shall be located on the driver's side of the floor and shall activate the air horn system.

### **AIR HORN PUSH BUTTON SWITCH**

One (1) push button switch shall be provided on the pump panel. The switch shall activate the air horn system.

### **EXHAUST SYSTEM MODIFICATION**

The chassis exhaust system shall be modified to exit on the passenger side of the apparatus ahead of the rear wheel.

### **EXHAUST HEAT WRAP**

The exhaust pipe shall be wrapped with heat wrap from the diesel particulate filter to just shy of the end of the tailpipe.

### **BUMPER BOX PROTECTIVE FLAP**

The protective flap shall be a cut down mud flap installed on the rear edge of the front bumper to eliminate debris from being deposited on the top of the front bumper and in the hose boxes.

### **REAR MUD FLAPS**

The chassis shall be supplied with mud flaps with BME's logo. The mud flaps shall be installed behind the rear wheels.

### **DRIVER'S SIDE UNDER CAB COMPARTMENT**

The apparatus shall be equipped with an enclosed stainless steel compartment located under the crew door on the drivers side of the cab. The compartments clear door opening shall measure approximately 32" wide x 12.5" high x 19.25" deep with a hinged aluminum door and a D-ring style latch.

The doors shall be painted job color.

### **BRASS BOX SLIDE TRAY**

The left under cab compartment shall have these additional items installed, a 10-gauge reinforced plain anodized aluminum sliding drawer-type tray with a 4-inch vertical flange on all sides to be utilized for the storage of nozzles and adapters.

The tray shall utilize the maximum available space within this compartment and have extra heavy duty 500 pound lock-in/lock-out roller glides with stops to prevent it from sliding all the way out and to hold it securely in place when the compartment door is opened or closed.

The brass box tray shall feature adjustable 16 section slotted 4-inch high "egg-crate" divider designed for vertical storage of various nozzles and adapters.

### **COMPARTMENT LIGHTING**

One (1) Code 3 800 Series Corner LED lights shall be installed in the specified compartment(s).

### **COMPARTMENT LIGHT SWITCHES**

Each interior compartment light shall be automatically controlled by a door activated "On-Off" switch.

### **PASSENGER'S SIDE UNDER CAB COMPARTMENT**

## Boise Mobile Equipment

The apparatus shall be equipped with an enclosed stainless steel compartment located under the crew door on the passenger side of the cab. The compartments clear door opening shall measure approximately 35" wide x 12.5" high x 15.25" deep with double hinged aluminum doors.

The doors shall be painted job color.

### **SLIDE TRAY**

A 250# capacity slide tray shall be installed in the specified under cab compartment. The chassis batteries shall be located on this tray in the undercab compartment.

### **COMPARTMENT LIGHTING**

One (1) Code 3 800 Series Corner LED lights shall be installed in the specified compartment(s).

### **COMPARTMENT LIGHT SWITCHES**

Each interior compartment light shall be automatically controlled by a door activated "On-Off" switch.

### **CAB STEPS**

Aggressive, extruded aluminum surfaces shall be installed on each of the cab steps areas.

### **CAB DOOR REFLECTIVE PANELS**

The cab doors shall include reflective trim installed inside each door.

Specified part shall include Red and White DOT approved reflective striping.

### **AIR HOSE OUTLET**

There shall be one (1) female quick connect air outlet provided and installed. The quick connect fitting shall provide connection to a utility air hose and shall be located on the drivers side pump operator's panel. There shall be a shut off located at the tank.

### **AIR TANK RELOCATION**

The air tanks shall be relocated to the rear of the truck between the frame rails.

### **BATTERY RELOCATION**

The chassis batteries are to be relocated to the passenger side of the chassis, below the rear cab door in a custom made under cab box.

### **UNDERHOOD LIGHTS**

There shall be two (2) Tecniq LED light(s) installed under the hood of the chassis. Lights shall have local switching on the driver side under the hood.

### **AIR FILTER EMBER PROTECTION SCREEN AND WARNING LABEL**

The chassis air intake shall be protected by an ember guard of 18 Mesh, 0.017-inch wire diameter, and a maximum mesh opening of 0.039 inches. The ember guard shall be sized to fit and located at the intake opening. The screen shall be readily accessible for inspection and maintenance.

### **EMBER SEPARATOR -- FRESH AIR INTAKE TO CAB**

The cabin air filter shall be protected by an ember guard with a maximum mesh opening of 0.039 inches.

### **EMBER SEPARATOR**

The final stage manufacturer shall install a stainless steel ember separator within the auxiliary fire pump engine air intake system.

### **FUEL TANK SKID PLATE**

A heavy duty removable skid plate shall be fastened to the bottom side of the fuel tank. The skid plate shall have the front and rear sides turned up to prevent digging into the ground when the apparatus is in off road conditions.

### **AIR, FUEL, ELECTRICAL LINE PROTECTION**

All air lines, fuel lines and electrical harnesses below the chassis frame rails shall be protected with fire resistive sleeves.

### **FUEL TANK VENTING**

The O.E.M fuel tank vent line shall be extended from the fuel tank and vented to the atmosphere. The vent line shall extend vertically from the tank to the bottom of the cab rear window and then bend 180 degrees towards the ground.

### **TIRE PRESSURE INDICATOR SYSTEM**

There shall be a tire pressure indicator at each tire's valve stem on the vehicle that shall indicate if there is insufficient pressure in the specific tire.

### **FIRE PUMP SPECIFICATIONS**

A Darley model JMP 500 GPM two stage fire pump shall be installed. Power to drive the pump shall be provided by the same engine used to propel the apparatus. The pump shall be equipped with a series-parallel changeover valve control on the pump panel.

Pump casing shall be a fine grain cast iron, with a minimum tensile strength of 30,000 PSI. Pump shall contain a cored heating jacket feature that, if selected, can be connected into the vehicle antifreeze system to protect the pump from freezing in cold climates, and to help reject engine heat from engine coolant, providing longer life for the engine. Seal rings shall be renewable, double labyrinth, wrap around bronze type.

The pump shaft shall be splined to receive broached impeller hubs, for greater resistance to wear, torsional vibration, and torque imposed by engine, as well as ease of maintenance and repair.

Bearings provided shall be heavy duty, deep groove, radial-type ball bearings. Sleeve bearings on any portion of the pump or transmission shall be prohibited due to wear, deflection, and alignment concerns. The bearings shall be protected at all openings from road dirt and water splash with oil seals and water slingers.

The impeller shall be a high strength bronze alloy, splined to the pump shaft for precision fit, durability, and ease of maintenance. Impeller shaft oil seals shall be constructed to be free from steel components except for the internal lip spring. The impeller shaft oil seals shall carry a lifetime warranty against damage from corrosion from water and other fire-fighting fluids.

The pump transmission case shall be heavy-duty cast iron with adequate oil reserve capacity to maintain low operating temperature. Pump ratio to be selected by the manufacturers engineering department. Gears shall be helical in design and precision ground for quiet operation and extended life. Gears to be cut from high strength alloy steel, ground, and carburized. Chain drive and/or design requiring extra lubricating pump is not acceptable.

Pump drive shaft shall be precision ground, heat-treated alloy steel, with a 1-3/8 spline. Gears shall be helical design, and shall be precision ground for quiet operation and extended life. The pump transmission shall require no further lubrication beyond that provided by the intrinsic action of the gears, to reduce the likelihood of failure due to loss of auxiliary lubrication.

### **MECHANICAL SEAL**

The mechanical seal shall use silicon carbide mechanical seals with welded springs. The stationary face of our mechanical seals shall be made from silicon carbide, an extremely hard and heat dissipative material, which resists wear and dry running damage.

### **PUMP SHIFT NO PUMP AND ROLL**

## Boise Mobile Equipment

The pump transmission shall be engaged by a guarded toggle switch which will lock in both the road and the pump mode to ensure that accidental pump engagement or disengagement is avoided.

The main fire pump shift controls shall be mounted in the cab and identified as "PUMP SHIFT" and shall include a permanently inscribed pump shift instruction I.D. plate. The pump shift controls shall include indicating lights located on the in-cab and left pump panels that advise the operator that the pump shift has been completed and it is O.K. to pump.

The main pump shall be used for stationary pumping only. The main pump shall include a lock-out system that is interfaced with the apparatus electrical and parking brake systems and is designed to keep the main pump from being used in pump and roll operations.

### **FIRE PUMP ANODE SYSTEM**

The fire pump plumbing system shall be provided with anode system to reduce corrosion within the piping. The anode shall be bolt-in or screw-in type and easily replaceable.

### **ELECTRIC PRIMER SPECIFICATIONS**

A 12 volt electrically driven positive displacement fire pump primer system shall be installed. The priming pump shall be constructed of heat treated aluminum and hard coat anodized and shall not use oil in the operation. The system shall perform in compliance to applicable NFPA standards.

### **FIRE PUMP TEST**

The fire pump shall undergo factory fire pump tests for a minimum of 30 minutes of continuous pump at rated capacity at rated net pump pressure prior to delivery of the completed apparatus. The complete pump test shall include a pressure control test, a priming system test, a vacuum test and a water tank to pump flow test. The factory pump testing results shall be furnished on delivery.

### **FIRE PUMP PTO AND DRIVELINES**

A "Hot Shift" power-take-off shall be installed on the transmission PTO opening with the controls located in the chassis cab, with an AMBER warning light to note engagement. The drive shaft and universals shall be sized for intended usage and pump rating.

### **INTAKE DUMP VALVE**

An Elkhart model #40/40 intake dump valve shall be provided and mounted on the suction side of the pump. The valve shall be preset from the factory at 125 psi. The discharge piping of the dump valve shall be a minimum of 2-1/2" diameter and shall terminate with a 2-1/2" male NST adapter. The excess water shall be

## Boise Mobile Equipment

discharged to the ground. A label shall be provided indicating: "DUMP VALVE DISCHARGE, DO NOT CAP".

### **BYPASS FIRE PUMP COOLER**

The fire pump shall be equipped with 3/8" cooling line from the pump to the water tank. This re-circulation line shall be controlled by a pump panel control valve with nameplate label noting it as the "fire pump bypass cooler".

### **OVERHEAT PROTECTION MANAGER**

The fire pump shall be equipped with an overheat protection device which monitors the temperature of the water inside the pump and relieves water when the temperature inside the pump exceeds 140 degrees Fahrenheit. The Waterous Model #OPM shall also have an warning light on the pump panel to provide additional protection in the event the temperature inside the pump continues to rise with the overheat protection valve open. The warning light and test button shall be mounted to a heavy polished casting that is mounted to the pump operator's panel.

### **MASTER PUMP DRAIN**

One (1) Trident, multiple-port drain valve, fabricated from bronze, shall be provided and controlled at the pump operator's control panel. The valve shall be opened by turning a rotary hand wheel. The valve shall be plumbed to drain both the discharge and intake sides of the pump, the relief valve and other plumbing components as required.

The valve shall be placed as low as possible to provide proper drainage of the components plumbed to it. The valve shall be rated to 600 PSI minimum and suitable for daily valve actuation.

### **MAIN PUMP PLUMBING**

The PTO main pump plumbing system shall utilize stainless steel piping incorporating hosing to allow for flex. The piping shall utilize TIG welding to provide a complete seal. Hard angles shall be avoided when possible to improve water flow characteristics. The piping shall utilize Victaulic couplers whenever possible to allow flex as the body module flexes.

Threaded sections of piping shall be avoided to reduce the leak potential of the system. Victaulic couplers shall be used in place of threading to reduce leak potential. Schedule 10 stainless steel piping shall be used for transport type piping. Schedule 40 stainless steel shall be used for areas requiring threading to provide a stable threading base. Brackets shall be installed to support threading locations thereby reducing the potential for leaks.

All hoses shall be connected directly to the tank due to the different flex ratios of the tank to body. Any front discharges, any rear discharges, and all cross lays shall use hose to reach the actual discharge. The use of hose

## Boise Mobile Equipment

shall be utilized due to the difference in flex or movement between the discharge location and the pump connection. Drain lines shall be provided at the lowest points in the plumbing system to allow for complete drainage. Bleeders shall be provided for all gauges to relieve pressure after use.

### PORTABLE PUMP

A Darley 1-1/2AGE 24K portable pump shall be provided on the apparatus. The unit shall have a liquid cooled, 24 HP, Kubota D902 diesel engine equipped with an electric start.

#### Pump Performance

20 gpm @ 310 psi  
140 gpm @ 145 psi  
180 gpm @ 80 psi

#### Diesel Engine

Kubota, D902 Diesel, water-cooled, 24 hp.

#### Fuel Supply

The engine shall be piped to the chassis fuel system with provisions to prevent fuel drain back to the tank when the engine is shutdown.

#### Fuel Prime

A fuel re-prime pump shall be provided to assist in fuel delivery to the diesel engine from the chassis tank.

#### Lubrication

Pressure feed with spin-on filter.

#### Starter

12-volt electric wired into the chassis battery system

#### Exhaust

A spark arrestor shall be provided on the engine exhaust system.

#### Air Intake

An air cleaner shall be provided with easy access to remove the element.  
An ember screen shall be provided on the inlet to the air cleaner.

The aux pump shall be capable of flowing water through the following discharges only.

Front bumper discharges  
Front bumper monitor (if applicable)  
Booster hose reel

## Boise Mobile Equipment

Cross lay pre connect discharges  
Rear 1-1/2" discharge

### **DUAL DARLEY DELUXE PANELS**

The auxiliary pump shall be controlled by a dual Darley, Deluxe panel set up. One panel shall be located on the pump panel and one panel shall be located in the cab console.

### **AUXILIARY PUMP PLUMBING**

The auxiliary fire pump plumbing system shall utilize stainless steel piping incorporating hosing to allow for flex. The piping shall utilize TIG welding to provide a complete seal. Hard angles shall be avoided when possible to improve water flow characteristics. The piping shall utilize Victaulic couplers whenever possible to allow flex as the body module flexes.

Threaded sections of piping shall be avoided to reduce the leak potential of the system. Victaulic couplers shall be used in place of threading to reduce leak potential. Schedule 10 stainless steel piping shall be used for transport type piping. Schedule 40 stainless steel shall be used for areas requiring threading to provide a stable threading base. Brackets shall be installed to support threading locations thereby reducing the potential for leaks.

All hoses shall be connected directly to the tank due to the different flex ratios of the tank to body. Any front discharges, any rear discharges, and all cross lays shall use hose to reach the actual discharge. The use of hose shall be utilized due to the difference in flex or movement between the discharge location and the pump connection.

### **AUXILIARY PUMP EXHAUST SYSTEM**

The auxiliary fire pump and engine assembly shall have a muffler and exhaust pipe. The exhaust pipe shall be directed out of the compartment and away from the pump operator. An additional guard shall be installed where the pipe is exposed to touch by an operator.

### **PRIMER ASSEMBLY**

The auxiliary pump shall use the main pump primer to prime the pump. Primer control shall be located on the aux pump control panel and shall utilize one primer for both pumps.

### **LOW PRESSURE PUMP SHUT-DOWN**

If the fire pump runs out of water and the pressure decreases below 20 PSI, an automatic pressure switch shall detect the condition, and turn off the fire pump operation.

### **LOW OIL PRESSURE / HIGH TEMPERATURE PUMP SHUT-DOWN**

## Boise Mobile Equipment

If the fire pump has low oil pressure or high engine temperature, automatic pressure switches shall detect the condition, and the device shall turn off the fire pump operation. There shall be an override switch provided and installed on the operators pump panel to allow the system to be disabled when required.

### **AUXILIARY FUEL SYSTEM**

The fuel system for the auxiliary fire pump shall be plumbed to the chassis fuel system. There shall be a separate fuel pickup tube mounted in the chassis fuel tank specifically for a separate engine driven pump assembly. There shall be an electric fuel pump with regulator and fuel hose furnished between the chassis fuel tank and the auxiliary pump.

### **AUXILIARY FIRE PUMP ELECTRIC START WIRING TO CHASSIS**

Properly sized 12 volt positive and negative cables shall be provided from the chassis battery to the auxiliary fire pump.

### **AUXILIARY AND MAIN PUMP PLUMBING**

The auxiliary fire pump shall be plumbed to the main pump discharge.

### **AUXILIARY PUMP OIL DRAIN EXTENSION**

There shall be an oil drain extension installed on the auxiliary pump. This will allow for the engine oil to be drained without removing the auxiliary engine.

### **4" UNGATED INTAKE -- LEFT SIDE**

One (1) 4" un-gated suction intake shall be installed on the left side pump panel to supply the fire pump from an external water supply. The threads shall be 4" NH male and equipped with a removable screen.

One (1) chrome brass 4" NH rocker lug cap with a securing chain or cable shall be installed on the intake.

### **2-1/2" GATED INTAKE -- LEFT SIDE**

One (1) 2-1/2" gated suction intake shall be recessed mounted on the left side pump panel to supply the fire pump from an external water supply. The valve shall be a quarter-turn ball valve with the appropriate handle and shall have 2-1/2" NH female thread.

The intake shall be equipped with a South Park Corp. 3/4" Push-pull type drain valve mounted to the bottom of the valve.

07/03/24

## Boise Mobile Equipment

One (1) Akron 8825 series swing-out style valve(s) shall be supplied and installed. All valves shall be designed to operate under normal conditions up to 500 PSI and shall have dual seats to work in both pressure and vacuum environments. All valves and controls shall be easily accessible for service, repair or replacement.

The specified valve shall have a direct actuated 'local' control Akron Model TSC valve handle.

One (1) chrome brass 2-1/2" NH rocker lug plug with a securing chain or cable shall be installed on the intake.

### **2-1/2" GATED INTAKE -- RIGHT SIDE**

One (1) 2-1/2" gated suction intake shall be recess mounted on the right side pump panel to supply the fire pump from an external water supply. The valve shall be a quarter-turn ball valve with the appropriate handle and shall have 2-1/2" NH female thread.

The intake shall be equipped with a South Park Corp. 3/4" Push-pull type drain valve mounted to the bottom of the valve.

One (1) Akron 8825 series swing-out style valve(s) shall be supplied and installed. All valves shall be designed to operate under normal conditions up to 500 PSI and shall have dual seats to work in both pressure and vacuum environments. All valves and controls shall be easily accessible for service, repair or replacement.

The specified valve shall have a direct actuated 'local' control Akron Model TSC valve handle.

One (1) chrome brass 2-1/2" NH rocker lug plug with a securing chain or cable shall be installed on the intake.

### **WATER TANK SUPPLY LINE TO FIRE PUMP**

A 3" water tank to pump line shall be installed, with a 3" full flow quarter turn ball valve and 3" piping. The line shall be equipped with a hump hose with stainless steel hose clamps and a 3" check valve to prevent pressurization of the water tank.

One (1) Akron 8830 series swing-out style valve(s) shall be supplied and installed. All valves shall be designed to operate under normal conditions up to 500 PSI and shall have dual seats to work in both pressure and vacuum environments. All valves and controls shall be easily accessible for service, repair or replacement.

The specified valve shall have a direct actuated 'local' control, Akron Model R1 valve handle.

The 3" valve shall be equipped with an air operated cylinder and control actuator installed on pump panel.

### **PUMP TO TANK**

## Boise Mobile Equipment

There shall be a pump to tank line provided from the discharge side of the pumps and plumbed to the top of the tank. The plumbing shall be 2-inch with a 2-inch Akron 8800 series ¼-turn full flow ball valve, and shall be controlled at the left pump panel by a push/pull T-handle and linkage. The pump to tank shall be plumbed to flow water from both the main and auxiliary pumps

One (1) Akron 8820 series swing-out style valve(s) shall be supplied and installed. All valves shall be designed to operate under normal conditions up to 500 PSI and shall have dual seats to work in both pressure and vacuum environments. All valves and controls shall be easily accessible for service, repair or replacement.

The specified valve shall have a direct actuated 'local' control, Akron Model R1 valve handle.

The valve shall be equipped with a Thuemling manually operated pull rod, with quarter-turn locking feature.

### **2-1/2" DISCHARGE LEFT SIDE – FORWARD PUMP PANEL**

One (1) 2-1/2" discharge shall be installed on the left side forward pump panel area controlled by a quarter turn ball valve with the appropriate handle. The discharge shall have 2-1/2" NH male hose threads, bleeder valve, and chrome brass cap, with a label adjacent the control handle.

A Class 1 quarter-turn 3/4" drain and bleeder valve shall be installed on the discharge valve.

One (1) Akron 8825 series swing-out style valve(s) shall be supplied and installed. All valves shall be designed to operate under normal conditions up to 500 PSI and shall have dual seats to work in both pressure and vacuum environments. All valves and controls shall be easily accessible for service, repair or replacement.

The specified valve shall have a direct actuated 'local' control Akron Model TSC valve handle.

One (1) chrome brass 2.5" NH rocker lug cap with a securing chain or cable shall be installed on the discharge.

### **LINE PRESSURE GAUGE**

There shall be one (1) 2.5" diameter -30-0-600 PSI pressure gauge internally lit.

The specified gauge shall feature a drain located at the gauge inlet to help prevent freezing. The drain shall be a twist open and close type.

Gauge(s) shall include internal, back-lit 12 volt lighting. Replaceable, White, LED bulb in a water-resistant holder.

Gauge(s) shall be supplied with a white dial face with black lettering and black gauge marks.

Gauge bezel shall be Chrome in color.

**2.5" DISCHARGE -- REAR LEFT**

One (1) 2.5" discharge shall be installed on the rear left panel with controlled by a quarter turn ball valve. The discharge shall have 2.5" NH male hose threads and nameplate label adjacent the control handle.

One (1) Akron 8825 series swing-out style valve(s) shall be supplied and installed. All valves shall be designed to operate under normal conditions up to 500 PSI and shall have dual seats to work in both pressure and vacuum environments. All valves and controls shall be easily accessible for service, repair or replacement.

The specified valve shall have a direct actuated 'local' control Akron Model TSC valve handle.

(1) chrome plated brass 30 degree elbow with 2.5" swivel female NH x 2.5" male NH thread with rocker lugs shall be provided on the discharge.

One (1) chrome brass 2.5" NH rocker lug cap with a securing chain or cable shall be installed on the discharge.

**2" DISCHARGE -- REAR RIGHT**

One (1) 2" discharge shall be installed on the rear right panel, controlled by a quarter turn ball valve on pump panel. The discharge shall have 2" NPT x 1-1/2" NH male hose threads and nameplate label adjacent the valve control handle.

One (1) Akron 8820 series swing-out style valve(s) shall be supplied and installed. All valves shall be designed to operate under normal conditions up to 500 PSI and shall have dual seats to work in both pressure and vacuum environments. All valves and controls shall be easily accessible for service, repair or replacement.

The specified valve shall have a direct actuated 'local' control Akron Model TSC valve handle.

One (1) chrome plated brass reducing adapter with a 2" female NH x 1.5" male NH thread with rocker lugs shall be provided on the discharge.

One (1) chrome plated brass 30 degree elbow with 1.5" swivel female NH x 1.5" male NH thread with rocker lugs shall be provided on the discharge.

One (1) chrome plated brass 1.5" NH rocker lug cap with a securing chain or cable shall be installed on the discharge.

**1-1/2" CROSSLAY DISCHARGES**

Two (2) 1-1/2" hose cross lays shall be installed over pump enclosure. One (1) each side. They shall be arranged in a single stack design with a divider in the center of the storage area. Each storage area shall extend from the

## Boise Mobile Equipment

side of the pump house to the center of the pump house. The dimensions shall be approximately 4-1/2" wide x 36" deep x 32" tall.

Two (2) Akron 8820 series swing-out style valve(s) shall be supplied and installed. All valves shall be designed to operate under normal conditions up to 500 PSI and shall have dual seats to work in both pressure and vacuum environments. All valves and controls shall be easily accessible for service, repair or replacement.

The specified valve shall have a direct actuated 'local' control Akron Model TSC valve handle.

The crosslay hosebed shall be equipped with an aluminum diamond plate hinged cover and vinyl end flap enclosures on each side, installed in compliance with applicable NFPA #1900 standards. The cover shall be equipped with rubber bumpers and lift up handle on each end of the cover.

The specified crosslay flaps shall be red.

### **CROSSLAY EDGES**

The crosslay side sheets shall be rolled on each side to act as a guide for the hose to come out of the tray.

Two (2) chrome plated brass reducing adapter with a 2" female NH x 1.5" male NH thread with rocker lugs shall be provided on the discharge.

Two (2) chrome plated brass 1.5" NH rocker lug cap with a securing chain or cable shall be installed on the discharge.

### **1-1/2" BUMPER AREA DISCHARGE (LEFT SIDE)**

One (1) 2" discharge shall be provided at the driver's side of the front bumper extension. The discharge shall be plumbed with 2" flexible high pressure hose with reusable fittings or welded stainless steel pipe. The front bumper discharge shall be equipped with a 2" quarter turn ball valve. The discharge shall have a 90 degree full swivel elbow, terminating in 1-1/2" NST male threads, to allow the hose to be pulled in any direction without kinking.

One (1) Akron 8820 series swing-out style valve(s) shall be supplied and installed. All valves shall be designed to operate under normal conditions up to 500 PSI and shall have dual seats to work in both pressure and vacuum environments. All valves and controls shall be easily accessible for service, repair or replacement.

The specified valve shall have a direct actuated 'local' control Akron Model TSC valve handle.

One (1) chrome plated brass 1.5" NH rocker lug cap with a securing chain or cable shall be installed on the discharge.

**1-1/2" BUMPER AREA DISCHARGE (RIGHT SIDE)**

One (1) 2" discharge, shall be provided at the passenger's side of the front bumper extension. The discharge shall be plumbed with 2" flexible high pressure hose with reusable fittings or welded stainless steel pipe. The front bumper discharge shall be equipped with a 2" quarter turn ball valve. The discharge shall have a 90 degree full swivel elbow, terminating in 1-1/2" NST male threads, to allow the hose to be pulled in any direction without kinking.

One (1) Akron 8820 series swing-out style valve(s) shall be supplied and installed. All valves shall be designed to operate under normal conditions up to 500 PSI and shall have dual seats to work in both pressure and vacuum environments. All valves and controls shall be easily accessible for service, repair or replacement.

The specified valve shall have a direct actuated 'local' control Akron Model TSC valve handle.

One (1) chrome plated brass 1.5" NH rocker lug cap with a securing chain or cable shall be installed on the discharge.

**2" ISOLATION VALVE**

One (1) 2" inline valve, labeled, shall be provided to isolate the front bumper extension discharge piping in the case of a hose or piping failure. This valve shall normally be left in the open position. Control for this valve shall be through the use of a R1 handle, painted red, located at the valve.

One (1) Akron 8820 series swing-out style valve(s) shall be supplied and installed. All valves shall be designed to operate under normal conditions up to 500 PSI and shall have dual seats to work in both pressure and vacuum environments. All valves and controls shall be easily accessible for service, repair or replacement.

The specified valve shall have a direct actuated 'local' control, Akron Model R1 valve handle.

**HOSE REEL**

There shall be one (1) Hannay aluminum hose reel(s) Model #SBSEPF17-28-29-RT shall be installed. The reel shall have leak proof ball bearing swing joint, adjustable friction brake, electric 12 volt rewind and manual crank rewind provisions. The reel shall be plumbed with wire reinforced, high-pressure hose coupled with brass fittings. The reel shall be designed to hold 125% of the specified hose capacity.

The reel shall be provided with a 12 volt electric motor of appropriate size for rewinding. The hose reel shall have provisions for being rewound manually. The pinion shaft for the manual rewind gear shall be equipped with an adjustable tension brake, controlled at the hose reel.

## Boise Mobile Equipment

One (1) Akron 8810 series swing-out style valve(s) shall be supplied and installed. All valves shall be designed to operate under normal conditions up to 500 PSI and shall have dual seats to work in both pressure and vacuum environments. All valves and controls shall be easily accessible for service, repair or replacement.

The specified valve shall have a direct actuated 'local' control Akron Model TSC valve handle.

### **HOSE REEL MOUNTING**

The hose reel shall be mounted over the pump enclosure.

Two (2) Cole Hersee #M-608 push button hose reel rewind controls shall be installed supplied and installed to rewind the hose reel. One (1) button shall be installed on the left pump panel and one (1) button shall be installed on the right panel.

### **HOSE REEL ROLLERS**

The hose reel shall include one horizontal and two vertical chrome fairlead rollers. Two (2) additional sets of fair lead rollers shall be located on the auxiliary pump cover for guiding the hose across the top of the apparatus.

### **FOAM SYSTEM**

A FoamPro electronic foam system shall be provided. The system shall be designed for use with Class A foam concentrate. The foam proportioning operation shall be designed for direct measurement of water flows and shall remain consistent within the specified flows and pressures. The system shall be capable of accurately delivering foam solution as required by applicable sections of the NFPA standards.

The system shall be equipped with a control module suitable for installation on the pump panel. There shall be a microprocessor incorporated within the motor driver that shall receive input from the system's flowmeter, while also monitoring the foam concentrate pump output. The microprocessor shall compare the values to ensure that the desired amount of foam concentrate is injected onto the discharge side of the fire pump. A "foam capable" paddlewheel-type flowmeter shall be installed in the discharge side of the piping system.

The control module shall enable the pump operator to:

- Activate the foam proportioning system
- Select the proportioning rates from 0.1% to 1.0%
- See a "low concentrate" warning light flash when the foam tank level becomes low and in two (2) minutes, if the foam concentrate has not been added to the tank, the foam concentrate pump shall be capable of shutting down.

A 12-volt electric motor driven positive displacement plunger pump shall be provided. The pump capacity range shall be 0.1 to 1.7 GPM (6.4L/min) at 200 PSI (13.8 BAR) with a maximum operating pressure up to 400 PSI

## Boise Mobile Equipment

(27.6 BAR). The system shall draw a maximum of 30 amps at 12 volts. The motor shall be controlled by the microprocessor which shall be mounted to the base of the pump. It receives signals from the control module and power the 1/3 horsepower (.25 Kw) electric motor in a variable speed duty cycle to ensure that the correct proportion of concentrate is injected into the water stream.

A full flow check valve shall be provided in the discharge piping to prevent foam contamination of the fire pump and water tank. A 5 PSI (.35 BAR) opening pressure check valve shall be provided in concentrate line.

Components of the complete proportioning system as described above shall include:

- Operator control module
- Paddlewheel flowmeter
- Pump and electric motor/motor driver
- Wiring harnesses
- Low level tank switch
- Foam tank
- Foam injection check valve
- Main waterway check valve
- Flowmeter and tee with 2" male NPT threads.

The foam system shall be installed and calibrated to manufacturer's requirements. In addition the system shall be tested and certified by the apparatus manufacturer to applicable NFPA standards.

The foam system design shall be tested and pass environmental testing in accordance to SAE standards.

An installation and operation manual shall be provided for the unit. The system shall have a one (1) year limited warranty by the foam system manufacturer.

The FoamPro 1600 Series foam system shall be provided with a control cable from the controller to the foam pump assembly.

The FoamPro 1600 Series foam system shall be provided with a standard pump panel mounted FoamPro control head.

A FoamPro brass flowmeter shall be provided. The flowmeter shall be installed in the "foam capable" discharge line. The flowmeter shall have maximum accuracy between the flow range of 15 GPM and 520 GPM and be capable of operation between 5 GPM to 625 GPM. The tee shall have NPT and Victaulic inlet and outlets connections.

A FoamPro instruction and system rating label shall be provided. The label shall display information for a FoamPro 1600 Series foam system and shall meet applicable sections of the NFPA standards.

## Boise Mobile Equipment

A FoamPro foam system schematic label shall be installed on the pump panel near foam controls. The label shall be a diagram of the FoamPro 1600 series foam system layout and shall meet applicable sections of the NFPA standards.

### **FOAM SYSTEM OUTLETS**

The following discharges shall have foam distributed to them.

- Front bumper discharges
- Front bumper monitor (if applicable)
- Pump house crosslay pre connects
- Booster hose reel
- Rear 1-1/2" discharge

### **FOAM SYSTEM CAB CONTROL**

A FoamPro on-off control switch shall be installed in the cab console.

### **FOAM UPLOAD SYSTEM**

There shall be a Hale EZ Foam upfill system supplied and installed on the apparatus.

### **PUMP MODULE ENCLOSURE**

The PTO fire pump enclosure shall be a separate unit from the body unit and shall be attached and supported at the chassis frame rails. This module shall allow for independent flexing of the pump enclosure from the body, chassis, and tank, and shall permit quick removal. The module shall have Polypro mounting pads and shall be attached to the frame rails. The pump module shall also house the auxiliary pump and hose reel mounted up above the plumbing. The bolt-on pump enclosure support structure shall be constructed of steel tubing.

The pump enclosure shall be approximately 27" front to rear, 72" right to left, and 60" high.

The top portion above the pump panel (operators side), and above the pump house compartment (right hand side) shall have a stainless steel overlay. The overlay shall contour around the front and rear of the pump module approx 3" and extend down the outer edges of the module on both sides left and right to the bottom of the module. On the front of the pump house module there shall be an ALDP overlay that extends from left to right along the top approx 8" tall.

There shall be polished stainless steel bezels around panel mounted discharge and intake valves, they will be removable for ease of service.

### **AUXILIARY PUMP COVER**

A louvered hinged cover with suitable latches shall be provided over the pump and power unit assembly. The area around the assembly shall remain open for maintenance and air circulation and the radiator shall be located behind ventilated side sheet.

### **DOOR AJAR SENSOR**

The Specified door(s) shall feature a magnetic proximity switch to indicate when the compartment door is ajar.

### **PUMP ENCLOSURE RUNNING BOARD**

Both the drivers and passenger side shall be equipped with a side running board a minimum of 12" deep. The running board shall extend along the width of the pump enclosure from the forward end of the body module to behind the chassis cab. The exterior edge of the running board shall be constructed of a non-slip aggressive surface, supported by the pump enclosure framework, and bolted in place with stainless steel fasteners.

### **PUMP ACCESS SERVICE DOOR -- UPPER LEFT SIDE**

The upper left side of the side mount pump enclosure shall be provided with a pump service access door. The hinged door shall be constructed of stainless steel powder coated satin black, with push button type lever latches for service access.

### **PUMP PANELS**

The pump panels shall be constructed of stainless steel, bolted to the pump enclosure with stainless steel fasteners. The operators side pump panel shall be powdercoated satin black, while the right side panel shall be brushed stainless steel.

### **MASTER PUMP DISCHARGE AND INTAKE GAUGES**

#### **MASTER INTAKE PRESSURE GAUGE**

One (1) master intake pressure gauge shall be provided on the operator's panel. The gauge shall be a Span brand, or equivalent, 30-0-150 PSI graduated, with a minimum diameter of 4-1/2", backlit for nighttime operations and silicone liquid filled to prevent condensation inside the gauge and to dampen the movement.

The gauge housing shall be constructed of Zytel nylon with a 1/4" NPT brass male fitting centrally located on the rear of the housing. The gauge shall be filled with low-temperature liquid with an operating range of -40 to +150 degrees Fahrenheit, which prevents bouncing of the readout needle and provides for an accuracy rating of 3% or 1" hg on the vacuum side and 5% or 15 PSI on the pressure side of the gauge.

## Boise Mobile Equipment

The specified gauge shall feature a drain located at the gauge inlet to help prevent freezing. The drain shall be a twist open and close type.

Gauge(s) shall include internal, back-lit 12 volt lighting. Replaceable, White, LED bulb in a water-resistant holder.

Gauge(s) shall be supplied with a white dial face with black lettering and black gauge marks.

Gauge bezel shall be Chrome in color.

### **MASTER DISCHARGE PRESSURE GAUGE**

One (1) master discharge pressure gauge shall be provided on the operator's panel. The gauge shall be a Span brand, or equivalent, 0-600 PSI graduated, with a minimum diameter of 4-1/2", backlit for nighttime operations and silicone liquid filled to prevent condensation inside the gauge and to dampen the movement.

The gauge housing shall be constructed of Zytel nylon with a 1/4" NPT brass male fitting centrally located on the rear of the housing. The gauge shall be filled with low-temperature liquid with an operating range of -40 to +150 degrees Fahrenheit, which prevents bouncing of the readout needle and provides for an accuracy rating of 5% or 15 PSI on the pressure side of the gauge.

Gauge(s) shall include internal, back-lit 12 volt lighting. Replaceable, White, LED bulb in a water-resistant holder.

Gauge(s) shall be supplied with a white dial face with black lettering and black gauge marks.

Gauge bezel shall be Chrome in color.

### **TEST TAPS**

Test taps for pump intake and pump pressure with name plate labels shall be provided on the pump instrument panel.

### **PRESSURE GOVERNOR and ENGINE MONITORING DISPLAY**

Fire Research PumpBoss series PBA401-D00 pressure governor and monitoring display kit shall be installed. The kit shall include a control module, intake pressure sensor, discharge pressure sensor, and cables. The control module case shall be waterproof and have dimensions not to exceed 6 3/4" high by 4 5/8". The control knob shall be 2" in diameter with no mechanical stops, have a serrated grip, and a red idle push button in the center. It shall not extend more than 1 3/4" from the front of the control module. Inputs for monitored engine

## Boise Mobile Equipment

information and outputs for engine control shall be on the J1939 databus. Inputs from the pump discharge and intake pressure sensors shall be electrical.

The following continuous displays shall be provided:

- Engine RPM; shown with four daylight bright LED digits more than 1/2" high
- Check engine and stop engine warning LEDs
- Engine oil pressure; shown on a dual color (green/red) LED bar graph display
- Engine coolant temperature; shown on a dual color (green/red) LED bar graph display
- Transmission Temperature; shown on a dual color (green/red) LED bar graph display
- Battery voltage; shown on a dual color (green/red) LED bar graph display
- Pressure and RPM operating mode LEDs
- Pressure / RPM setting; shown on a dot matrix message display
- Throttle ready LED.

The dot-matrix message display shall show diagnostic and warning messages as they occur. It shall show monitored apparatus information, stored data, and program options when selected by the operator. All LED intensity shall be automatically adjusted for day and night time operation.

The program shall store the accumulated operating hours for the pump and engine to be displayed with the push of a button. It shall monitor inputs and support audible and visual warning alarms for the following conditions:

- High Battery Voltage
- Low Battery Voltage (Engine Off)
- Low Battery Voltage (Engine Running)
- High Transmission Temperature
- Low Engine Oil Pressure
- High Engine Coolant Temperature
- Out of Water (visual alarm only)
- No Engine Response (visual alarm only).

The program features shall be accessed via push buttons located on the front of the control module. There shall be a USB port located at the rear of the control module to upload future firmware enhancements.

The governor shall operate in two control modes, pressure and RPM. No discharge pressure or engine RPM variation shall occur when switching between modes. A throttle ready LED shall light when the interlock signal is recognized. The governor shall start in pressure mode and set the engine RPM to idle. In pressure mode the governor shall automatically regulate the discharge pressure at the level set by the operator. In RPM mode the governor shall maintain the engine RPM at the level set by the operator except in the event of a discharge pressure increase. The governor shall limit a discharge pressure increase in RPM mode to a maximum of 30 psi. Other safety features shall include recognition of no water conditions with an automatic programmed response and a push button to return the engine to idle.

The pressure governor and display shall be programmed to interface with a Cummins engine.

**WATER TANK GAUGE**

One (1) Fire Research TankVision model WLA300-A00-S20 tank gauge shall be installed on the pump panel. The water tank indicator kit shall include an electronic indicator module, a pressure sensor, and a 10' sensor cable. The indicator shall show the volume of water in the tank on nine (9) easy to see super bright LEDs.

The specified level gauge shall be active anytime the chassis battery switch is turned on.

**WATER TANK GAUGE**

One (1) Fire Research TankVision model WLA300-A00-S20 tank gauge shall be installed on the cab console. The water tank indicator kit shall include an electronic indicator module, a pressure sensor, and a 10' sensor cable. The indicator shall show the volume of water in the tank on nine (9) easy to see super bright LEDs. The gauge shall be powered when the parking brake is released and the aux pump is engaged.

**WATER TANK VOLUME REMOTE INDICATOR**

Two (2) Fire Research TankVision model WLA280-A00 tank remote indicator shall be installed. The indicator shall show the volume of water in the tank on Ninety six (96) easy to see super bright Tri-color LEDs. The indicator case shall be waterproof, manufactured of Polycarbonate material with an integrated lens. The package includes a rubber gasket.

The remote indicator shall receive input information over a datalink from a Fire Research TankVision primary indicator model WLA200-A00, WLA300-A00 or WLA400-A00. The remote indicator shall indicate the level as a single color in Red for 25% or less, Amber color for up to 50% volume, Blue color for up to 75% volume and Green color for up to 100% volume. When the level reaches 25%, the red LEDs will begin flashing. When the level is empty, the red LEDs will scroll in a down-chasing motion and then flash three times. It shall have the program capability to adjust the brightness level for day time and nighttime viewing.

The specified level gauge shall be active anytime the chassis battery switch is turned on.

**CLASS A FOAM TANK GAUGE**

One (1) Fire Research brand, Model WLA360-A00 tank level gauge shall be provided on the pump operator's panel to monitor the foam concentrate storage tank level. The gauge shall indicate the foam concentrate storage tank liquid level on an LED bar graph display.

The specified level gauge shall be active anytime the chassis battery switch is turned on.

**NOMENCLATURE PLATES**

## Boise Mobile Equipment

The apparatus shall be equipped with color coded labels. The labels shall be furnished for discharges, intakes, and for other controls and indicators. All labels shall be in English format.

### **MIDSHIP PUMP PANEL LIGHTS -- DRIVERS SIDE**

There shall be three Tecniq brand LED lights installed under a stainless steel light shield mounted above the pump panel. The two outer lights shall be operated by a panel mounted switch, while the middle light will only be activated upon pump engagement.

One (1) of the pump panel lights shall illuminate at the time the fire pump is engaged.

### **MIDSHIP PUMP PANEL LIGHTS -- PASSENGER SIDE**

There shall be one Tecniq brand LED light installed under a stainless steel light shield mounted above the pump panel. The light shall activate upon pump engagement.

### **PUMP ENCLOSURE WORK LIGHTS**

Two (2) LED work lights shall be installed in the pump enclosure. The work lights shall have clear lenses and shall have a control switch.

### **DESIGN AND SCOPE OF WILDLAND BODY**

The body shall be designed and constructed of commonly available structural components for ease of repair and maintenance. The body shall be of a modular design with the body structure independent of the chassis frame rails. The body module shall be mounted to the chassis frame rails utilizing a unique double spring mounting system for flexibility and durability over the lifetime of the apparatus. The fabrication of the body shall be of welded construction to withstand the rigors of fire service use.

The body shall be designed to incorporate and support the tank, hose bed, compartments, and all other equipment intended to be stored in or mounted to the body module. The body skeleton and compartment framework shall be designed of tubular members for increased strength and stress resistance. There shall be no sheet metal or extrusions utilized in the foundation or structural components of the body module due to their critical role in assuring lifetime durability, functionality and usability.

### **BODY FRAMEWORK**

The entire body framework shall be fabricated from steel tubing. The body framework shall be a completely welded unit, forming a connected, stable frame for strength, longevity and providing the skeleton of the body module. The internal upright members of the framework shall act as support for the top layer of the body module. The external upright members shall act as an exoskeleton providing form and support for compartments

## Boise Mobile Equipment

while acting as the external surfaces of the module. The framework shall define the compartment openings and provide a rigid mounting location for all compartments and doors.

The foundation cross-members shall be placed perpendicular to the chassis frame rails in the wheel well area extending the full width of the body and shall be constructed of 3 inch high x 2 inch wide x .25 inch tubing. The foundation members parallel to the chassis frame rails shall be constructed of 3 inch square x .25 inch tubing and shall connect the foundation cross members and extend the full length of the body.

All tank support cross members shall be placed to support the water tank as per the tank manufacture's recommendation. These supports shall be constructed of 3 inch high x 2 inch wide x .25inch steel tubing. The tank support angles shall be constructed of 4 inch x 4 inch x .25 inch thick angles and shall be placed at the tank sides parallel to the chassis frame rails to provide lateral support for the tank and protection from debris from the wheels.

The internal upright supports for top layer components shall be placed to provide support for all components located on the top layer of the body module and shall be constructed of steel tubing measuring 2 inch square x .25 inch wall thickness. All front to rear connecting members shall be 3 inches high x 2 inches wide x .125 inch wall thickness and shall be placed in between the interior upright support members to provide rigidity, stability and support to all top layer components. All gussets shall be constructed of 2 inches high x 3 inches wide x .25 inch thick plate which shall be placed on the top and bottom of the foundation cross members where they intersect with the exterior members.

### **BODY MOUNTING SYSTEM**

The mounting assembly shall be designed to isolate and protect the body module from vibration and twisting stresses imparted by the flexing of the chassis frame rails. The body module shall employ spring loaded body mounting assemblies. Each two piece mounting assembly shall be designed to positively position the body on the frame rails while allowing lateral and forward or aft movement. Mounting assemblies shall be placed forward and rearward of the rear axle as necessary to provide a strong and stable mounting of the body module

Each mounting assembly shall consist of a "male" upper mounting bracket and a "female" lower mounting bracket. The upper mounting brackets shall be fabricated from .25 inch thickness steel plate, with .250 inch painted steel lower mounting brackets. The upper mounting brackets shall be welded directly to the foundation connecting members. The lower mounting brackets shall be bolted to the exterior side facing surface of the chassis frame rails.

The mounting brackets shall be aligned and connected by two (2) 5/8 inch diameter grade 8 bolts equipped with compression springs. The springs shall be of the appropriate tension rating for the weight requirements of the body module. The mounting assembly shall be designed to completely eliminate sheering forces on the mounting bolts.

The foundation connecting members shall be placed on top of the chassis frame rails for added strength and

## Boise Mobile Equipment

stability. The foundation members shall be isolated from the steel chassis frame rails by .25 inch thickness steel plates which have .5 inch thick 80 durometer rubber pads vulcanized to the bottom surface of each plate. The steel plates shall be welded to the bottom of the foundation, doubling as additional gussets at foundation cross member joints.

### **COMPARTMENT FLOOR, SWEEP OUT STYLE**

Each compartment shall feature a raised floor sufficient enough to allow debris to be removed easily from the compartment.

### **BODY MATERIAL**

All materials utilized shall be of the correct type, alloy, and thickness to withstand the intended usage and provide protection against cracking, corrosion or metal fatigue. The body compartments shall be fabricated using 14 gauge steel for most compartments unless otherwise stated. Any use of proprietary parts or materials in the construction of the body shall be unacceptable, due to potential delays or difficulties in an unlikely event of future repairs or when service becomes necessary.

All external upright supports for integral compartments shall incorporate a second set of upright supports constructed of 3 inch wide x 2 inch deep x .250 inch wall thickness and shall be located outboard of the internal upright supports to provide a rigid structure for the compartments to be mounted to. The compartment openings shall be constructed of 3 inch high x 2 inch wide x .125 inch wall thickness cross members and shall be placed in between the external upright supports to define the openings of all enclosed body compartments again, providing a rigid mounting location for compartments.

### **COMPARTMENTATION**

All compartments shall be constructed of 14 gauge E.G. steel welded for strength and shall be sealed from the elements. The compartments shall be attached to the steel superstructure only, in order to maintain a truly modular design. Each compartment shall feature a smooth edges and surfaces from the walls to each weld without burs or sharp edges in the material.

### **DRIVER'S SIDE BODY COMPARTMENTS**

#### **COMPARTMENT D1**

One compartment shall be provided on the driver's side of the apparatus body above the rear wheels. This compartment shall span from just behind the pump panel to the back of the rear wheel well quarter panel. The compartments approximate "clear door opening" is 51" wide by 39" high with a variable depth of 13.5"/22".

### **COMPARTMENT VENTILATION**

## Boise Mobile Equipment

A minimum 2-inch single "Weber" style polished stainless steel swivel vent with four (4) ¼-inch vent holes shall be provided. These vents shall have a stainless steel center bolt to lock the vent in either the open or closed position and be located in the compartment walls. All vents will contain fire resistant filters to minimize dust entering the compartment.

### **COMPARTMENT FLOOR DRAIN**

The compartment shall be provided with rear corner floor drains to the underside of the body.

### **COMPARTMENT SILL PLATE**

The compartment shall feature a polished stainless steel sill plate protecting the painted surface of the compartment when items are accessed.

### **ADJUSTABLE UNISTRUT**

Adjustable Uni-Strut equipment mounting tracks shall be installed inside the compartment with two (2) channels on the left wall and two (2) channels on the right wall. The tracks shall be positioned to provide support for equipment mounting. The length of the tracks shall be sized to allow for optimum use of the compartment interior.

Adjustable Uni-Strut equipment mounting tracks shall be installed inside the compartment with two (2) vertical channels on the back wall of the compartment.

### **ADJUSTABLE SHELF**

There shall be (1) adjustable shelf(elvs) installed; and the shelf(elvs) shall be constructed of .125" thick smooth aluminum plate and be mounted in the specified compartment with double bolt aluminum shelf brackets. The shelf(elvs) shall have a broken front edge, and a broken rear edge for added strength and reinforcement.

### **COMPARTMENT SHELF GRATING**

The specified compartment shelf shall be fitted with removable interlocking vinyl Dri-Dek grating. This material shall be resistant to heat, cold, ultra-violet radiation, mechanical impacts, chemical actions and is corrosion resistant.

The specified Dri-Dek grating shall be black in color.

The compartment shelf and or shelves shall have reflective striping added to the outside lip. The stripe shall be a 1-1/2" minimum in width.

Specified part shall include Red and White DOT approved reflective striping.

### **COMPARTMENT GRATING**

The compartments shall be fitted with removable interlocking vinyl Dri-Dek grating. This material shall be resistant to heat, cold, ultra-violet radiation, mechanical impacts, chemical actions and is corrosion resistant.

### **COMPARTMENT GRATING EDGE**

The Dri-Dek grating shall be equipped with beveled edges where required.

The specified Dri-Dek grating shall be black in color.

### **COMPARTMENT LIGHTING**

The specified compartment shall have two (2) vertical and one (1) horizontal Code 3 800 series lights installed.

### **DOOR AJAR SENSOR**

The Specified door(s) shall feature a magnetic proximity switch to indicate when the compartment door is ajar.

### **COMPARTMENT D2**

One full height compartment shall be provided on the driver's side of the apparatus body aft of the rear wheels. This compartment shall span from behind the rear wheel well quarter panel to the rear of the body in width and from the top of the body to the rub rail in height. The compartments approximate "clear door opening" is 34" wide by 58" high with a variable depth of 13.5"/22".

### **COMPARTMENT VENTILATION**

A minimum 2-inch single "Weber" style polished stainless steel swivel vent with four (4) ¼-inch vent holes shall be provided. These vents shall have a stainless steel center bolt to lock the vent in either the open or closed position and be located in the compartment walls. All vents will contain fire resistant filters to minimize dust entering the compartment.

### **COMPARTMENT FLOOR DRAIN**

The compartment shall be provided with rear corner floor drains to the underside of the body.

### **COMPARTMENT SILL PLATE**

The compartment shall feature a polished stainless steel sill plate protecting the painted surface of the compartment when items are accessed.

**ADJUSTABLE UNISTRUT**

Adjustable Uni-Strut equipment mounting tracks shall be installed inside the compartment with two (2) channels on the left wall and two (2) channels on the right wall. The tracks shall be positioned to provide support for equipment mounting. The length of the tracks shall be sized to allow for optimum use of the compartment interior.

Adjustable Uni-Strut equipment mounting tracks shall be installed inside the compartment with two (2) vertical channels on the back wall of the compartment.

**ADJUSTABLE SHELF**

There shall be (1) adjustable shelf(elvs) installed; and the shelf(elvs) shall be constructed of .125" thick smooth aluminum plate and be mounted in the specified compartment with double bolt aluminum shelf brackets. The shelf(elvs) shall have a broken front edge, and a broken rear edge for added strength and reinforcement.

**COMPARTMENT SHELF GRATING**

The specified compartment shelf shall be fitted with removable interlocking vinyl Dri-Dek grating. This material shall be resistant to heat, cold, ultra-violet radiation, mechanical impacts, chemical actions and is corrosion resistant.

The specified Dri-Dek grating shall be black in color.

The compartment shelf and or shelves shall have reflective striping added to the outside lip. The stripe shall be a 1-1/2" minimum in width.

Specified part shall include Red and White DOT approved reflective striping.

**COMPARTMENT GRATING**

The compartments shall be fitted with removable interlocking vinyl Dri-Dek grating. This material shall be resistant to heat, cold, ultra-violet radiation, mechanical impacts, chemical actions and is corrosion resistant.

**COMPARTMENT GRATING EDGE**

The Dri-Dek grating shall be equipped with beveled edges where required.

The specified Dri-Dek grating shall be black in color.

**COMPARTMENT LIGHTING**

## Boise Mobile Equipment

The specified compartment shall have two (2) vertical and one (1) horizontal Code 3 800 series lights installed.

### **DOOR AJAR SENSOR**

The Specified door(s) shall feature a magnetic proximity switch to indicate when the compartment door is ajar.

## **PASSENGER SIDE BODY COMPARTMENTS**

### **COMPARTMENT P1**

One compartment shall be provided on the passenger's side of the apparatus body above the rear wheels. This compartment shall span from just behind the pump panel to the back of the rear wheel well quarter panel in width and from the top of the body side to the wheel well in height. The compartments approximate "clear door opening" is 51" wide by 39" high with a depth of 12".

### **COMPARTMENT VENTILATION**

A minimum 2-inch single "Weber" style polished stainless steel swivel vent with four (4) ¼-inch vent holes shall be provided. These vents shall have a stainless steel center bolt to lock the vent in either the open or closed position and be located in the compartment walls. All vents will contain fire resistant filters to minimize dust entering the compartment.

### **COMPARTMENT FLOOR DRAIN**

The compartment shall be provided with rear corner floor drains to the underside of the body.

### **COMPARTMENT SILL PLATE**

The compartment shall feature a polished stainless steel sill plate protecting the painted surface of the compartment when items are accessed.

### **ADJUSTABLE UNISTRUT**

Adjustable Uni-Strut equipment mounting tracks shall be installed inside the compartment with two (2) channels on the left wall and two (2) channels on the right wall. The tracks shall be positioned to provide support for equipment mounting. The length of the tracks shall be sized to allow for optimum use of the compartment interior.

Adjustable Uni-Strut equipment mounting tracks shall be installed inside the compartment with two (2) vertical channels on the back wall of the compartment.

## Boise Mobile Equipment

### **ADJUSTABLE SHELF**

There shall be (1) adjustable shelf(elvs) installed; and the shelf(elvs) shall be constructed of .125" thick smooth aluminum plate and be mounted in the specified compartment with double bolt aluminum shelf brackets. The shelf(elvs) shall have a broken front edge, and a broken rear edge for added strength and reinforcement.

### **COMPARTMENT SHELF GRATING**

The specified compartment shelf shall be fitted with removable interlocking vinyl Dri-Dek grating. This material shall be resistant to heat, cold, ultra-violet radiation, mechanical impacts, chemical actions and is corrosion resistant.

The specified Dri-Dek grating shall be black in color.

The compartment shelf and or shelves shall have reflective striping added to the outside lip. The stripe shall be a 1-1/2" minimum in width.

Specified part shall include Red and White DOT approved reflective striping.

### **COMPARTMENT GRATING**

The compartments shall be fitted with removable interlocking vinyl Dri-Dek grating. This material shall be resistant to heat, cold, ultra-violet radiation, mechanical impacts, chemical actions and is corrosion resistant.

### **COMPARTMENT GRATING EDGE**

The Dri-Dek grating shall be equipped with beveled edges where required.

The specified Dri-Dek grating shall be black in color.

### **COMPARTMENT LIGHTING**

The specified compartment shall have two (2) vertical and one (1) horizontal Code 3 800 series lights installed.

### **DOOR AJAR SENSOR**

The Specified door(s) shall feature a magnetic proximity switch to indicate when the compartment door is ajar.

### **COMPARTMENT P2**

One compartment shall be provided on the passenger's side of the apparatus body aft of the rear wheels. This compartment shall span from behind the rear wheel well quarter panel to the rear of the body in width and from

## Boise Mobile Equipment

below the walkway to the rub rail in height. The compartments approximate "clear door opening" is 34" wide by 58" high with a variable depth of 12"/22".

### **COMPARTMENT VENTILATION**

A minimum 2-inch single "Weber" style polished stainless steel swivel vent with four (4) ¼-inch vent holes shall be provided. These vents shall have a stainless steel center bolt to lock the vent in either the open or closed position and be located in the compartment walls. All vents will contain fire resistant filters to minimize dust entering the compartment.

### **COMPARTMENT FLOOR DRAIN**

The compartment shall be provided with rear corner floor drains to the underside of the body.

### **COMPARTMENT SILL PLATE**

The compartment shall feature a polished stainless steel sill plate protecting the painted surface of the compartment when items are accessed.

### **ADJUSTABLE UNISTRUT**

Adjustable Uni-Strut equipment mounting tracks shall be installed inside the compartment with two (2) channels on the left wall and two (2) channels on the right wall. The tracks shall be positioned to provide support for equipment mounting. The length of the tracks shall be sized to allow for optimum use of the compartment interior.

Adjustable Uni-Strut equipment mounting tracks shall be installed inside the compartment with two (2) vertical channels on the back wall of the compartment.

### **ADJUSTABLE SHELF**

There shall be (1) adjustable shelf(elvs) installed; and the shelf(elvs) shall be constructed of .125" thick smooth aluminum plate and be mounted in the specified compartment with double bolt aluminum shelf brackets. The shelf(elvs) shall have a broken front edge, and a broken rear edge for added strength and reinforcement.

### **COMPARTMENT SHELF GRATING**

The specified compartment shelf shall be fitted with removable interlocking vinyl Dri-Dek grating. This material shall be resistant to heat, cold, ultra-violet radiation, mechanical impacts, chemical actions and is corrosion resistant.

The specified Dri-Dek grating shall be black in color.

## Boise Mobile Equipment

The compartment shelf and or shelves shall have reflective striping added to the outside lip. The stripe shall be a 1-1/2" minimum in width.

Specified part shall include Red and White DOT approved reflective striping.

### **COMPARTMENT GRATING**

The compartments shall be fitted with removable interlocking vinyl Dri-Dek grating. This material shall be resistant to heat, cold, ultra-violet radiation, mechanical impacts, chemical actions and is corrosion resistant.

### **COMPARTMENT GRATING EDGE**

The Dri-Dek grating shall be equipped with beveled edges where required.

The specified Dri-Dek grating shall be black in color.

### **COMPARTMENT LIGHTING**

The specified compartment shall have two (2) vertical and one (1) horizontal Code 3 800 series lights installed.

### **DOOR AJAR SENSOR**

The Specified door(s) shall feature a magnetic proximity switch to indicate when the compartment door is ajar.

## **BACK BODY COMPARTMENTS**

### **COMPARTMENT B1**

One compartment shall be provided at the back of the apparatus body, below the hose bed and above the tailboard. This compartment shall span just center of the tank. The compartments approximate "clear door opening" is 27" wide by 34" high with a depth of 25".

### **COMPARTMENT VENTILATION**

A minimum 2-inch single "Weber" style polished stainless steel swivel vent with four (4) 1/4-inch vent holes shall be provided. These vents shall have a stainless steel center bolt to lock the vent in either the open or closed position and be located in the compartment walls. All vents will contain fire resistant filters to minimize dust entering the compartment.

### **COMPARTMENT FLOOR DRAIN**

## Boise Mobile Equipment

The compartment shall be provided with rear corner floor drains to the underside of the body.

### **COMPARTMENT SILL PLATE**

The compartment shall feature a polished stainless steel sill plate protecting the painted surface of the compartment when items are accessed.

### **ADJUSTABLE UNISTRUT**

Adjustable Uni-Strut equipment mounting tracks shall be installed inside the compartment with two (2) channels on the left wall and two (2) channels on the right wall. The tracks shall be positioned to provide support for equipment mounting. The length of the tracks shall be sized to allow for optimum use of the compartment interior.

Adjustable Uni-Strut equipment mounting tracks shall be installed inside the compartment with two (2) horizontal channels on the back wall of the compartment.

### **ADJUSTABLE SHELF**

There shall be (1) adjustable shelf(elvs) installed; and the shelf(elvs) shall be constructed of .125" thick smooth aluminum plate and be mounted in the specified compartment with double bolt aluminum shelf brackets. The shelf(elvs) shall have a broken front edge, and a broken rear edge for added strength and reinforcement.

### **COMPARTMENT SHELF GRATING**

The specified compartment shelf shall be fitted with removable interlocking vinyl Dri-Dek grating. This material shall be resistant to heat, cold, ultra-violet radiation, mechanical impacts, chemical actions and is corrosion resistant.

The specified Dri-Dek grating shall be black in color.

The compartment shelf and or shelves shall have reflective striping added to the outside lip. The stripe shall be a 1-1/2" minimum in width.

Specified part shall include Red and White DOT approved reflective striping.

### **COMPARTMENT GRATING**

The compartments shall be fitted with removable interlocking vinyl Dri-Dek grating. This material shall be resistant to heat, cold, ultra-violet radiation, mechanical impacts, chemical actions and is corrosion resistant.

### **COMPARTMENT GRATING EDGE**

## Boise Mobile Equipment

The Dri-Dek grating shall be equipped with beveled edges where required.

The specified Dri-Dek grating shall be black in color.

### **COMPARTMENT LIGHTING**

The specified compartment shall have two (2) vertical Code 3 800 series lights installed.

### **DOOR AJAR SENSOR**

The Specified door(s) shall feature a magnetic proximity switch to indicate when the compartment door is ajar.

### **PUMP HOUSE COMPARTMENT (PH1)**

There shall be a compartment located on the upper passenger side of the pump house. The compartment dimensions shall be approximately 21" wide x 23" high x 12" deep.

### **COMPARTMENT VENTILATION**

A minimum 2-inch single "Weber" style polished stainless steel swivel vent with four (4) ¼-inch vent holes shall be provided. These vents shall have a stainless steel center bolt to lock the vent in either the open or closed position and be located in the compartment walls. All vents will contain fire resistant filters to minimize dust entering the compartment.

### **COMPARTMENT FLOOR DRAIN**

The compartment shall be provided with rear corner floor drains to the underside of the body.

### **ADJUSTABLE UNISTRUT**

Adjustable Uni-Strut equipment mounting tracks shall be installed inside the compartment with two (2) channels on the left wall and two (2) channels on the right wall. The tracks shall be positioned to provide support for equipment mounting. The length of the tracks shall be sized to allow for optimum use of the compartment interior.

### **ADJUSTABLE SHELF**

There shall be (1) adjustable shelf(elvs) installed; and the shelf(elvs) shall be constructed of .125" thick smooth aluminum plate and be mounted in the specified compartment with double bolt aluminum shelf brackets. The shelf(elvs) shall have a broken front edge, and a broken rear edge for added strength and reinforcement.

## Boise Mobile Equipment

### **COMPARTMENT SHELF GRATING**

The specified compartment shelf shall be fitted with removable interlocking vinyl Dri-Dek grating. This material shall be resistant to heat, cold, ultra-violet radiation, mechanical impacts, chemical actions and is corrosion resistant.

The specified Dri-Dek grating shall be black in color.

The compartment shelf and or shelves shall have reflective striping added to the outside lip. The stripe shall be a 1-1/2" minimum in width.

Specified part shall include Red and White DOT approved reflective striping.

### **COMPARTMENT GRATING**

The compartments shall be fitted with removable interlocking vinyl Dri-Dek grating. This material shall be resistant to heat, cold, ultra-violet radiation, mechanical impacts, chemical actions and is corrosion resistant.

### **COMPARTMENT GRATING EDGE**

The Dri-Dek grating shall be equipped with beveled edges where required.

The specified Dri-Dek grating shall be black in color.

### **COMPARTMENT LIGHTING**

The specified compartment shall have two vertical Code 3 800 series lights installed.

### **DOOR AJAR SENSOR**

The Specified door(s) shall feature a magnetic proximity switch to indicate when the compartment door is ajar.

### **PUMP HOUSE COMPARTMENT (PH2)**

There shall be a compartment located on the lower passenger side of the pump house. The compartment dimensions shall be approximately 11.5" wide x 18" high x 18" deep.

### **COMPARTMENT FLOOR DRAIN**

The compartment shall be provided with rear corner floor drains to the underside of the body.

### **DOOR AJAR SENSOR**

## Boise Mobile Equipment

The Specified door(s) shall feature a magnetic proximity switch to indicate when the compartment door is ajar.

### **SLIDE-IN REAR LADDER COMPARTMENT - PASSENGER SIDE**

The rear passenger side of the apparatus body shall have a vertically mounted slide-in ladder storage compartment. The compartment shall be **capable** of storing one (1) \*20-foot three-section Duo Safety model #912 ladder, one (1) \*backboard minimum dimensions 72" L x 16" W x 2" H (Ferno "Najo Light NB5500" or similar), one (1) \*8-foot long pike pole and one (1) \*5-foot digging bar, one (1) \*8-foot rubbish hook, \*New York Roof Hook with locking pins to secure each item.

\*Items are to be purchased by the end user.

### **DOOR AJAR SENSOR**

The Specified door(s) shall feature a magnetic proximity switch to indicate when the compartment door is ajar.

### **SLIDE-IN REAR SUCTION HOSE COMPARTMENTS**

Two (2) suction hose storage compartments will be located above the side storage compartments on both sides of the apparatus. The compartments will hold a combined total of three (3) eight (8) foot sections of four (4) inch hard suction hose and strainer.

Both compartments will be capable of holding two (2) eight (8) foot sections of hose if needed. Each compartment will have a stainless steel painted hinged door on the rear of the compartment. Each compartment door will have a locking positive latching door latch.

### **DOOR AJAR SENSOR**

The Specified door(s) shall feature a magnetic proximity switch to indicate when the compartment door is ajar.

### **TOP COMPARTMENT TC1**

The hose bed shall be provided with a compartment down the center of the hosebed. The top compartment shall have a one piece aluminum treadplate cover. Approximate "clear door opening" dimensions shall be 13" wide by 75" deep and 16" high.

### **ALUMINUM TREADPLATE DOOR**

This compartment shall feature an embossed aluminum diamond plate lid. The lid shall be bare embossed aluminum diamond plate.

**DOOR LATCH**

The specified hinged door(s) shall be equipped with a sealed, black lever latch(es). Latch(es) shall be non-locking style.

**LIGHTING**

The specified compartment shall have no compartment lighting.

**DOOR AJAR SENSOR**

The Specified door(s) shall feature a magnetic proximity switch to indicate when the compartment door is ajar.

**PAINTED ALUMINUM PANEL**

There shall be a smooth aluminum panel bolted to the rear of the center top storage box.

**WHEEL WELL PANEL CONSTRUCTION**

The outer wheel well panel shall be galvaneal steel of the same gauge as compartment construction and an integral part of the overall body design. The exterior wheel well area shall be painted to match the body.

**WHEEL WELL LINERS**

Wheel well liners designed to protect the body from impact resulting from road debris thrown by the tires shall be installed. The removable liners shall be constructed from UHMW material to encompass the entire inner wheel well area. The liners shall be secured with stainless steel threaded fasteners.

**REAR WHEEL FENDERETTES**

Polished stainless steel fenderettes shall be installed at each rear wheel opening. The fenderettes shall be positioned outside of the wheel well panel to cover the tire area that extends past the body. The fenderettes shall be secured with stainless steel threaded fasteners.

**DRIVERS SIDE BODY -- SCBA CYLINDER STORAGE PROVISIONS**

A storage area for an SCBA cylinder shall be provided in the forward area of the driver's side wheel well. Dimensions shall be 8" diameter x 26" deep.

The SCBA door shall be a Cast Products door.

## Boise Mobile Equipment

The SCBA cylinder storage tube shall be made from plastic. There shall be rubber matting to cushion the bottle glued into the tube.

### **DOOR LATCH**

The specified hinged door(s) shall be equipped with (1), textured chrome lever latch(es). Latch(es) shall be non-locking style with a raised button.

### **SCBA CYLINDER STRAPS**

There shall be a 1" nylon tether installed to secure the bottle in the storage tube.

### **DRIVERS SIDE BODY -- SCBA CYLINDER STORAGE PROVISIONS**

A storage area for an SCBA cylinder shall be provided in the rearward area of the driver's side wheel well. Dimensions shall be 8" diameter x 26" deep.

The SCBA door shall be a Cast Products door.

The SCBA cylinder storage tube shall be made from plastic. There shall be rubber matting to cushion the bottle glued into the tube.

### **DOOR LATCH**

The specified hinged door(s) shall be equipped with (1), textured chrome lever latch(es). Latch(es) shall be non-locking style with a raised button.

### **SCBA CYLINDER STRAPS**

There shall be a 1" nylon tether installed to secure the bottle in the storage tube.

### **PASSENGER SIDE BODY – SCBA CYLINDER STORAGE PROVISIONS**

A storage area for an SCBA cylinder shall be provided in the forward area of the passenger's side wheel well. Dimensions shall be 8" diameter x 26" deep.

The SCBA door shall be a Cast Products door.

The SCBA cylinder storage tube shall be made from plastic. There shall be rubber matting to cushion the bottle glued into the tube.

### **DOOR LATCH**

## Boise Mobile Equipment

The specified hinged door(s) shall be equipped with (1), textured chrome lever latch(es). Latch(es) shall be non-locking style with a raised button.

### **SCBA CYLINDER STRAPS**

There shall be a 1" nylon tether installed to secure the bottle in the storage tube.

### **PASSENGER SIDE BODY -- SCBA CYLINDER STORAGE PROVISIONS**

A storage area for an SCBA cylinder shall be provided in the rearward area of the passenger's side wheel well. Dimensions shall be 8" diameter x 26" deep.

The SCBA door shall be a Cast Products door.

The SCBA cylinder storage tube shall be made from plastic. There shall be rubber matting to cushion the bottle glued into the tube.

### **DOOR LATCH**

The specified hinged door(s) shall be equipped with (1), textured chrome lever latch(es). Latch(es) shall be non-locking style with a raised button.

### **SCBA CYLINDER STRAPS**

There shall be a 1" nylon tether installed to secure the bottle in the storage tube.

### **RUB RAILS, CLEARANCE LIGHTS, AND REFLECTIVE TAPE**

The sides of the lower body area fore and aft of the wheel well area shall be provided with 2" x 1.25" x .250" extruded aluminum rub rails, with end caps or angled corners.

Specified part shall include White reflective striping.

### **FRONT OF BODY -- PROTECTIVE SURFACE**

The entire front of the apparatus body shall include a protective surface, constructed of aluminum tread plate material.

### **FRONT CORNERS OF BODY -- PROTECTIVE SURFACES**

## Boise Mobile Equipment

The front corners of the apparatus body shall include a protective surface installed. The surface shall be constructed of polished stainless steel material.

### **REAR BODY PANELS**

The entire rear of the apparatus body shall be painted apparatus color.

### **OUTER REAR BODY PANELS -- PROTECTIVE COVERING**

The rear outer panels of the body shall have protective surfaces installed on the corners. The protective covering shall be constructed of polished stainless steel material.

### **TOP OF BODY COMPARTMENTS -- PROTECTIVE SURFACES**

The top of the side compartments shall have a protective surfaces installed. The surface shall be constructed of aluminum tread plate material.

### **ANODIZED ALUMINUM DRIP RAIL**

All enclosed compartment doors shall be provided with an aluminum drip rail above the doors.

### **ALUMINUM – COMPARTMENT DOOR, HINGED OVERLAP**

One (1) single, vertically hinged door shall be provide and fabricated from aluminum. The frame of the door shall be constructed of 1.75" x 1.75" x .125" aluminum tubing to prevent corrosion and provide structural support. The spacing created by the frame tubing shall filled with Styrofoam for added support, dent resistance, insulation and noise reduction. The exterior surface shall be .125" aluminum for durability. The interior surface shall be .080" aluminum. There shall be no mechanical fasteners, such as bolt heads or rivets on the inside or outside of the doors.

The exterior of the door shall overlap the opening of the compartment. A .75" lip shall be constructed around the opening of the compartment and the exterior of the door. A rubber seal shall be installed on the .75" lip on both the compartment and the door to provide for a double seal against water and dust.

The door shall be designed utilizing a D-ring style latch system. A 6" stainless steel D-ring latch, large enough to accommodate a gloved hand, shall be mounted on the exterior of the door. A stainless steel bezel shall be installed to house and protect the D-ring locking mechanism. The easily serviced bezel shall be mounted utilizing stainless steel screws. The D-ring locking mechanism shall be a double catch design. The first catch shall engage to secure the door in the event of improper closure. The second catch shall seal the door from water and other elements once the door has been properly closed.

## Boise Mobile Equipment

The door shall be mounted using a stainless steel piano style hinge and a .25" diameter hinge pin for stability. The vertical hinge shall be mounted to the body frame with threaded inserts and stainless steel screws to preserve functionality and ease of maintenance in the event of damage.

Gas struts shall be utilized to hold the door in the open position and to prevent the door from slamming during closing. The gas struts shall be mounted directly to the door with a stainless steel bracket assembly for stability and ease of maintenance. The gas struts shall be mounted to the interior of the compartment with a fully adjustable assembly.

The exterior of the compartment doors shall be painted to match the body in quality and tone. The interior surface shall not be painted, it shall be sanded utilizing a dual orbital technique.

The specified door(s) shall have a Polished stainless-steel D-ring door handle.

The specified door(s) D-ring handles shall be equipped with manual key door locks keyed to use the 1250 key.

### **COMPARTMENT DOOR EDGE STRIPING**

The hinged compartment doors shall have reflective striping applied on the edges. The stripe shall be a 1-1/2" minimum in width.

Specified part shall include Red and White DOT approved reflective striping.

### **ALUMINUM – COMPARTMENT DOOR, HINGED OVERLAP**

There shall be five (5) double, vertically hinged sets of doors fabricated from aluminum and installed on the apparatus body. Each door shall feature exterior surfaces which overlaps the opening of the compartment. The exterior surface shall be .125" aluminum for durability and damage resistance. The interior surface shall be .080" aluminum for structural support and overall appealing appearance of the compartment. The frame of the doors shall be constructed of 1.75" x 1.75" x .125" aluminum tubing to prevent corrosion and provide structural support. The spacing created by the frame tubing shall be filled with Styrofoam for added support and dent resistance, temperature insulation, and noise reduction.

A .75" lip shall be constructed around the opening of the compartment and the exterior of the door. A rubber seal shall be installed on the .75" lip of both the compartment and the door to provide for a double seal against water and dust. A rain gutter shall be mounted above the latch type door for an added third layer of water protection.

The doors shall be designed utilizing a D-ring latch system. A 6 inch stainless steel D-ring latch, large enough to accommodate a gloved hand, shall be mounted on the exterior of the door to allow the door to seal and fasten in the closed position. A stainless steel bezel shall be installed to house and protect the D-ring locking mechanism. The easily serviced bezel shall be mounted utilizing stainless steel screws for added stability of the mechanism

## Boise Mobile Equipment

and ease of maintenance in the event of damage. The D-ring locking mechanism shall be of a double catch design. The first catch shall engage to secure the door in the event of improper closure. The second catch will seal the door to water and other elements once the doors has been properly closed.

The doors shall be mounted with a stainless steel hinges with .25" diameter hinge pin for stability. The vertical hinges shall be mounted to the body frame with threaded inserts and stainless steel screws to preserve functionality with use or age and ease of maintenance in the event of damage.

Gas struts shall be utilized to hold the door in the open position and to prevent the door from slamming during closing. The gas struts are mounted directly to the door with a stainless steel bracket assembly for stability and ease of maintenance. The gas struts shall be mounted to the interior of the compartment with fully adjustable assembly for ease of adjustment and maintenance while increasing stability.

The specified door(s) shall have a Polished stainless-steel D-ring door handle.

The specified door(s) D-ring handles shall be equipped with manual key door locks keyed to use the 1250 key.

### **COMPARTMENT DOOR EDGE STRIPING**

The hinged compartment doors shall have reflective striping applied on the edges. The stripe shall be a 1-1/2" minimum in width.

Specified part shall include Red and White DOT approved reflective striping.

### **REAR STEP**

The rear bumper shall be made from aluminum diamondback grip strut. The design of the grip strut shall allow for no debris or dust buildup and will allow for easy clean out with just water.

The step shall be of a three piece design each section to operate independently during body and chassis flexing. The step will be full body width.

The drop step will have locking positions to allow for up position storage and rear compartment door opening access.

### **AUXILIARY FIXED STEP -- DRIVERS SIDE REAR**

Three (3) Cast Products square cast aluminum auxiliary step(s) shall be provided. The step shall be installed on the rear drivers side of the body.

### **AUXILIARY FIXED STEP -- PASSENGER SIDE REAR**

## Boise Mobile Equipment

Three (3) Cast Products square cast aluminum auxiliary step shall be provided. The step shall be installed on the rear passenger side of the body.

### **HANDRAILS**

One (1) knurled type non-slip handrail, approximately 18" in length, shall be vertically installed.

### **HANDRAILS**

Two (2) knurled type non-slip handrail, approximately 42" in length, shall be vertically installed.

### **HANDRAILS**

Two (2) knurled type non-slip handrail, approximately 12" in length, shall be horizontally installed.

### **HANDRAILS**

Two (2) knurled type non-slip handrail, approximately 18" in length, shall be horizontally installed.

### **HANDRAILS**

One (1) knurled type non-slip handrail, approximately 60" in length, shall be horizontally installed.

### **HOSE BODY CONSTRUCTION SPECIFICATIONS**

The hose bed side sheets and floor shall be constructed from aluminum material. The hosebed shall provide two separate hose beds one on the left and one on the right side of the top loaded center dunnage. The hose body shall be free of sharp corners, bolts, or other obstructions that may catch hose and other equipment.

### **HOSE STORAGE BRACKETS**

There shall be two (2) I-Zone hose bracket(s) provided on the rear of the apparatus body one on each side left and right. The mount(s) shall be mounted under CPI fixed step(s). Approx length of the I-zone pole shall be 24".

### **ALUMINUM HOSEBED GRATING**

The hose bed compartment deck shall be constructed entirely from maintenance-free, extruded aluminum slats. The slats shall feature an anodized, contoured, ribbed top surface. The slats shall be of widths approximately 3/4" high x 4.5" wide and shall be welded into a one-piece grid system to prevent the accumulation of water and allow ventilation to assist in drying hose.

### **ALUMINUM HOSEBED COVER**

Two (2) separate aluminum tread plate hose bed covers shall be installed, 1/8-inch aluminum alloy diamond plate reinforced with a 1/8-inch aluminum alloy hat section as needed to support walking on the hose bed covers. The covers shall be hinged on the outboard side using full length polished stainless steel hinges with a minimum 3/8-inch pin and 1-inch joint length and installed to avoid any hindrance in walking on hose bed covers.

The hose bed covers shall have full length handrails installed along the rear lip of the covers and two (2) mechanisms on each cover to assist with opening and closing of the hose bed covers. Each hose bed cover shall have a mechanism to hold the hose bed cover in the open position and will be substantial enough to prevent accidental closing in extreme wind conditions.

The covers shall be reinforced so that they will support the weight of a person walking on the cover and shall be sloped to the outboard side of the apparatus to aid in water run-off.

### **HOSEBED REAR ENCLOSURE**

A vinyl end skirt with three (3) straps, and large quick release buckles (minimum 2-inch) shall be installed on each hose bed cover. Quick release buckles and nylon tie down straps shall be attached to the end skirts. The end skirts will be weighted at the bottom end with a full width flat strip of metal sewn into the hem of the skirt. The end skirts, straps, buckles, etc. will be exposed to direct sun light and shall be protected against UV rays.

The flaps shall be red in color.

### **HOSEBED -- AREA LIGHTS**

(4) Tecniq E10 lights shall be provided and installed on hosebed door(s).

### **DOOR AJAR SENSOR**

The Specified door(s) shall feature a magnetic proximity switch to indicate when the compartment door is ajar.

### **WATER TANK SPECIFICATIONS**

A 500 gallon booster tank (Poly Tank) shall be fabricated from a minimum of .500" polypropylene complete with a minimum of .375" polypropylene internal full height baffles that are raised 4" off the tank floor for maximum water flow between baffles. In addition, provisions for the main pump outlet, direct tank filler inlet, a pump to tank filler/churn valve inlet, a back pump filler outlet, a fitting for an electronic water level gauge sensor and clean outs for manual tank flushing shall be provided. The tank shall be structurally reinforced and restrained to prevent deformities or damage to the tank or apparatus body during stressed off road operations. The booster tank shall be a rectangular design, and shall be capable of being completely removable from the

## Boise Mobile Equipment

body without cutting or bending of any components. The tank and cradle assembly shall be mounted to the chassis frame in strict accordance to the tank manufacturer's installation guidelines.

The water tank shall be configured in a rectangular style with consistent widths on the sides from top to bottom.

### **TANK FILL AND OVERFLOW PROVISIONS**

The water tank shall have a combination vent and manual fill tower. The fill tower shall be fabricated from 1/2" polypropylene and shall have a minimum outer perimeter dimension of 8" x 8". The tower shall have a 1/4" thick polypropylene screen and a polypropylene hinged cover. Inside the fill tower, halfway down from the top, shall be fastened a vent overflow pipe. The vent overflow shall be fabricated from Schedule 40 polypropylene pipe, with a minimum I.D. of 4". The vent overflow shall be designed to run through the tank interior and shall be designed to exit the water tank interior behind the rear wheels.

The tank cover shall be fabricated from 1/2" thick polypropylene and shall incorporate a three-piece design which allows for the removal of each individual cover section for inspection or repair of the tank interior, if necessary. The tank cover shall be recessed 3/8" from the top of the tank sides and shall be welded to both the sides and the longitudinal baffles. Each of the three cover sections shall have hold downs to assist in keeping the cover rigid under fast filling conditions. These hold downs shall consist of 2" polypropylene dowels, spaced a maximum of 30" apart, fitted and then welded to the transverse partitions. The dowels shall extend through the cover sections and be welded to them. Two of the dowels shall be drilled and tapped to accommodate the tank lifting eyes.

The sump shall have a minimum dimension of 8" x 6" with a 3/4" thick bottom. On all tanks with a bulkhead suction inlet, a 3" Schedule 40 polypropylene pipe sweep shall be provided from the front of the tank to the sump location. The sump shall have a threaded plug located at the bottom of it for a tank drain and clean out.

There shall be two standard tank outlets: one for the tank to pump suction line, which shall be a minimum of a 3" NPTF coupling, and one for a tank fill line, which shall be a minimum of a 1-1/2" NPTF coupling. All tank fill couplings shall be backed with flow deflectors to break up the stream of water entering the tank.

The water tank shall rest on the body subframe cross members, which shall be spaced a maximum of 22" apart. The tank shall be insulated from those cross members by hard rubber insulators, with a minimum thickness of 1/4", glued and mechanically fastened to the cross members to protect the tank from direct contact with the steel body subframe. The tank shall be designed on a free-floating suspension principle and shall not require the use of additional hold downs. The tank shall be completely removable without disturbing or dismantling the apparatus body structure.

### **VENT AND OVERFLOW**

## Boise Mobile Equipment

The fill tower shall incorporate a vent and overflow system shall be designed into the water tank. The system shall include a 3" diameter PVC pipe that functions both as an air vent while emptying the tank and as an overflow when filling the tank. The overflow shall discharge excess water below the frame rails of the vehicle.

### **TANK SUMP AND DRAIN PROVISIONS**

A one (1) cubic foot (minimum) polypropylene sump, with anti-swirl baffles shall be provided. The sump shall be located as close to the center of the tank floor as the chassis cross members, and differential driveline will allow.

One (1) 3-inch or 4-inch National Pipe Thread (NPT) outlet and plug shall be provided in the sump floor for flushing of the tank. A 1½-inch drain valve shall be provided in the tank sump for flushing of the booster tank. The valve will be located as to provide for adequate clearance from cross members and differential during extreme twisting motions of the chassis and buildup

The sump shall also be provided with a 1-inch NPT outlet for the back pump filler hose.

Due to space constraints, it may be necessary to locate the main pump suction outlet in the tank sump for maximum water usage. The main pump suction tube will be of an adequate size to supply the main pump with enough water to meet pump ratings.

A minimum 3-inch direct tank fill NPT inlet and internal manifold shall be provided on the left rear of the tank. If the direct tank fill inlet is located on the rear tank wall, the inlet manifold shall pass through the first baffle and feature a turn down to eliminate any possible damage to the tank or baffles while filling the tank.

### **WATER TANK DRAIN PROVISIONS**

A 3" plugged drain provision shall be installed in the bottom of the water tank, sump, or plumbing for water tank draining and the flushing-out of debris.

### **CLASS A FOAM TANK SPECIFICATIONS**

The Class A foam tank shall have a capacity of 20 gallons. The foam tank shall be manufactured by UPF and have a lifetime warranty.

The tank shall be equipped with a positive sealing pressure/vacuum vent type cap, a low foam concentrate sensor that turns off the foam pump at a pre-set level, a visual sight gauge, an easily accessible brass or stainless steel drain valve located at the lowest point of the foam tank and an accessible brass or stainless steel cleanable strainer installed in the supply line from the foam tank to the foam pump.

The foam tank shall be mounted on a removable sub-structure. The tank will have a positive tie down. The tie down will allow for easy removal of the foam tank.

## Boise Mobile Equipment

The foam tank will have two (2) quarter turn brass or stainless shut off valves at the pump supply and fill lines to allow for the removal of the tank without loss of foam. The float switch harness and the foam concentrate supply and fill lines shall have connections located adjacent to the tank to facilitate foam tank removal.

### **FOAM TANK FILL AND VENTING PROVISIONS**

The foam concentrate tank shall be provided with a fill pipe having a volume of not less than 2 percent of the total tank volume. The filler opening shall be capped with a sealed air-tight threaded cover. The fill opening shall be designed to incorporate a removable screen and shall be located so that foam concentrate from a five (5) gallon container can be dumped into the tank.

The foam tank filler shall be equipped with a pressure/vacuum vent that enables the tank to compensate for changes in pressure or vacuum when filling or withdrawing foam concentrate from the tank. The pressure/vacuum vent shall not allow atmospheric air to enter the foam tank except during operation or to compensate for thermal fluctuations. The vent shall be protected to prevent foam concentrate from escaping or directly contacting the vent at any time. The vent shall be of sufficient size to prevent tank damage during filling or foam withdrawal.

A color coded label or visible permanent marking that reads "CLASS A -- FOAM TANK FILL" shall be placed at or near the foam concentrate tank fill opening. An additional label shall be placed at or near any foam concentrate tank fill opening stating the type of foam concentrate the system is designed to use.

Any restrictions on the types of foam concentrate that can be used with the system shall also be stated, along with a warning message that states "WARNING: DO NOT MIX BRANDS AND TYPES OF FOAM."

A 3/4" diameter connection, piping, and gate type valve shall be installed for the foam tank for draining purposes.

### **DIRECT TANK FILL - REAR DRIVERS SIDE**

A valve for direct filling of the tank shall be supplied. The 1/4 turn valve shall be configured with 2-1/2" NH female threads, debris screen, threaded plug with retention chain and lever handle. The valve shall be located on the drivers side rear of the apparatus.

One (1) Akron 8825 series swing-out style valve(s) shall be supplied and installed. All valves shall be designed to operate under normal conditions up to 500 PSI and shall have dual seats to work in both pressure and vacuum environments. All valves and controls shall be easily accessible for service, repair or replacement.

The specified valve shall have a direct actuated 'local' control Akron Model TSC valve handle.

One (1) chrome brass 2-1/2" NH rocker lug plug with a securing chain or cable shall be installed on the intake.

## Boise Mobile Equipment

(1) chrome plated brass 30 degree elbow with 2.5" swivel female NH x 2.5" male NH thread with rocker lugs shall be provided on the direct tank fill.

### **BACK PACK FILL SYSTEM**

There shall be one (1) back pack fill system provided and installed on the lower area of the pump panel. The valve plumbing shall be 3/4" I.D. hose.

### **12 VOLT ELECTRICAL SPECIFICATIONS**

The following describes the low voltage electrical system on the apparatus including all panels, electrical components, switches and relays, wiring harnesses and other electrical components. The apparatus manufacturer shall conform to the latest Federal DOT standards, current automotive electrical system standards, and the applicable requirements of the NFPA 1906.

Wiring shall be stranded copper or copper alloy conductors of a gauge rated to carry 125 percent of the maximum current for which the circuit is protected. Voltage drops shall not exceed 10 percent in all wiring from the power source to the using device. The wiring and wiring harness and insulation shall be in conformance to applicable SAE and NFPA standards. The wiring harness shall conform to SAE J-1128 with GXL temperature properties. Exposed wiring shall be run in a loom with a 290 degree Fahrenheit rating. Wiring looms shall be properly supported and attached to body members. Electrical conductors shall be constructed in accordance with applicable SAE standards, except when good engineering practice requires special construction.

All wiring connections and terminations shall provide positive mechanical and electrical connections and be installed in accordance with the device manufacturer's instructions. When wiring passes through metal panels, electrical connections shall be with mechanical type fasteners and rubber/plastic grommets.

Wiring between cab and body shall be split using Deutsch type connectors or enclosed in a terminal junction panel allowing body removal with minimal impact on the apparatus electrical system. Connections shall be insulated with heat shrink crimp-type tubing to resist moisture and foreign debris such as grease and road grime. Weather resistant connectors shall be provided throughout the system.

Electrical junction or terminal boxes shall be weather resistant and located away from water spray conditions. When required, automatic reset breakers and relays shall be housed in the main body junction panel.

There shall be no exposed electrical cabling, harnesses, or terminal connections located in compartments, unless enclosed in an electrical junction box or covered with a removable electrical panel. Wiring shall be secured in place and protected against heat, liquid contaminants and damage and shall be uniquely identified at least every six inches (6") by color coding or permanent marking with a circuit function code and identified on a reference chart or electrical wiring schematic per requirements of applicable NFPA 1906 standards.

## Boise Mobile Equipment

Low voltage protective devices shall be provided for the electrical circuits. The devices shall be accessible and located in required terminal connection locations or weather resistant enclosures. Over current protection devices shall be automatic reset type suitable for electrical equipment and meet SAE standards. All electrical equipment, switches, relays, terminals, and connectors shall have a direct current rating of 125 percent of maximum current for which the circuit is protected. Electro-magnetic interference suppression shall be provided in the system as required in applicable SAE standards.

The electrical system shall include the following:

Electrical terminals in weather exposed areas shall have a non-conductive grease or spray applied. All terminal plugs located outside of the cab or body shall be treated with a corrosion preventative compound.

All electrical wiring shall be placed in a protective loom or be harnessed.

Exposed connections shall be protected by heat shrink material and sealed connectors.

Large fender washers shall be used when fastening equipment to the underside of the cab roof and all holes made in the roof shall be caulked with silicone.

Electrical components installed in exposed areas shall be mounted in a manner that will not allow moisture to accumulate inside.

A service loop shall be provided behind an electrical appliance to allow them to be pulled away from mounting area for inspection and service work.

Upon completion of the vehicle and prior to delivery, the apparatus shall be electrically tested and the electrical testing, certifications, and test results shall be submitted with delivery documentation per requirements of NFPA 1906.

### **ELECTRICAL WIRING HARNESS**

The electrical system shall be divided into separate harnesses. The individual harness shall be connected with Deutsch type quick connectors. The wiring and appliances shall be protected by automatic reset type circuit breakers.

### **CUSTOM FABRICATED CONSOLE**

A custom fabricated electrical console and enclosure shall be located between the driver's and the officer's seating positions. The console shall feature a fixed lid with optional radio mounting locations located at the front of the console. The console shall have two (2) cup holders.

The specified compartment(s) shall be coated with Hamlet Black colored Multi-Spec paint.

### **12 VOLT POWER SOURCE**

## Boise Mobile Equipment

There shall be two (2) 12 volt plug-in utility power connection(s) rated at 20 amps provided and installed in the cab console.

The specified power source shall be wired to the switched battery circuit.

### **USB CHARGING PORT**

Two (2) USB charging port(s) shall be installed in the cab of the truck for the fire departments accessory devices. The USB charging port shall have two (2) USB connections and shall have a 5 volt, 4.8A output with Intelligent Device Recognition capabilities.

The specified power source shall be wired to the switched battery circuit.

### **BATTERY SWITCH - MASTER DISCONNECT**

A battery cutoff switch shall be provided in the cab within easy reach of the driver; by the chassis manufacturer. The switch shall be rated for 300 amps.

### **BATTERY CHARGER**

A Kussmaul Autocharge 1000 PLC, model #091-215-12, automatic battery charger shall be provided. The battery charger shall be wired to the 12 volt battery system. The unit shall be mounted in a clean, dry area accessible for service and/or maintenance. It shall be wired to the specified shore power receptacle. Included in the package is a Kussmaul Super 20 Auto Eject Deluxe with built in bar graph display. Mounting location shall be determined in pre-con

The specified auto eject cover shall be yellow.

### **IDENTIFICATION LIGHTS**

All LED identification lights shall be installed on the vehicle as required by applicable highway regulations.

### **LICENSE PLATE MOUNTING AND LIGHT**

A predrilled backing plate and LED light shall be installed on the rear for mounting of the license plate.

Stop, Tail, Turn Lights, Whelen M Series, Quad, Package

### **STOP AND TAIL LIGHTS**

Two (2) Whelen Model #M62BTTC, 4" x 6" LED brake, tail, turn lights with clear lenses shall be provided. The light shall be furnished with a Clear optic polycarbonate lens for maximum light spread and furnished with

07/03/24

## Boise Mobile Equipment

a 6" wire pigtail. The light can be used in combination with a separated turn signal, or alone as a Brake, tail, and turn light.

### TURN SIGNALS

Two (2) Whelen M62TC light heads shall be installed on the apparatus. The lightheads shall feature an Clear lens with sequential chevron arrow, with multi flash pattern.

### BACK-UP LIGHTS

Two (2) Whelen M-Series M62BU, 4" x 6" rear LED back-up lights shall be installed.

### TAILLIGHT BEZELS

Two chrome (2) Whelen M Series housings shall be installed at the rear of the apparatus for four (4) Whelen M-Series stop-tail-turn-backup and warning lights.

### ZONE C- LOWER REAR WARNING LIGHTS

Two (2) Whelen M6 Series Model # M6RC warning light shall be provided. The warning light shall incorporate Linear Super-LED® and Smart LED® technology. The M6RC configuration shall consist of 18 red Super-LEDs and a clear optic polycarbonate lens.

The lens/reflector assembly shall be sealed and resistant to water, moisture, dust, and other environmental conditions. The hard coated lens shall provide extended life/luster protection against UV and chemical stresses.

### MAP LIGHT

One (1) Havis Shields #C-MAP-T-LED 12" LED map light, 12 volt, with a gooseneck arm an on-off switch located on the base of the light shall be installed on the dashboard.

### FRONT BUMPER -- GROUND LIGHTS

There shall be two (2) Tecniq E10, LED ground light(s) installed under the front bumper.

The ground lights shall be activated when parking brake is set, or the transmission is placed into park (where applicable).

### CAB GROUND LIGHTS

There shall be four (4) Tecniq E10, LED ground lights installed under the cab door(s).

## Boise Mobile Equipment

The ground lights shall be activated when parking brake is set, or the transmission is placed into park (where applicable).

### **GROUND LIGHTS - PUMP PANEL**

There shall be two (2) Tecniq E10, LED ground lights installed under the pump panel running board(s).

The ground lights shall be activated when parking brake is set, or the transmission is placed into park (where applicable).

### **GROUND LIGHTS - UNDER REAR STEP**

There shall be two (2) Tecniq E10, LED ground lights installed under the rear step area.

The ground lights shall be activated when parking brake is set, or the transmission is placed into park (where applicable).

### **PIONEER MICRO**

There shall be two (2) Whelen Pioneer Micro lights provided and installed on the apparatus.

The lights shall be located:

- Two located under the middle steps on the back of the apparatus. They shall be operated by the "Rear Scene" switch located on the Whelen siren controller

### **PIONEER MICRO**

There shall be two (2) Whelen Pioneer Micro lights provided and installed on the apparatus. They shall be located in the center section of the front bumper in provided cutouts. The lights shall be controlled by a button labeled "Scene Front" on the whelen siren controller.

The forward facing scene light(s) shall be activated by individual buttons or switches on the cab center console.

### **PIONEER FLOOD/SPOT SURFACE MOUNT LIGHTHEAD**

Four (4) Whelen Pioneer Plus™ Model # PCPSM1C shall be provided and installed on the apparatus. The light head shall have a chrome housing.

## **Boise Mobile Equipment**

The scene lights shall be activated by individual buttons or switches on the cab center console. Left, right, and rear scene light controls.

### **DOOR OPEN WARNING LIGHT**

The door ajar warning system shall be separated into four zones, a Front, Left, Right, and Rear zone. Each zone shall have an individually labeled warning light and also activate an audible alarm. The door ajar lights and audible alarm shall activate only when the apparatus parking brake has been released.

### **RADIO ANTENNA INSTALLATION**

There shall be four (4) radio antenna installed on the apparatus and routed to the cab center console.

### **BACK UP ALARM**

One (1) solid state back up alarm shall be provided at the rear of the apparatus. The back up alarm shall be wired to the reverse circuit of the transmission, and shall provide an audible alarm to the rear of the apparatus when reverse gear is selected. The alarm shall have a volume of 87 to 112 db while in operation.

### **HEADLIGHT FLASHER**

The headlights shall be set to alternate flash (Wig-Wag).

The wig wag shall be triggered by the siren controller slide switch position 3.

### **ELECTRONIC SIREN**

A Whelen CenCom Core C399 electric siren and lighting control module shall be installed.

### **WHELEN CORE CONTROL HEAD**

There shall be a Whelen model CCTL6 control head supplied with the Cencom Core system. It features a 3 section control head, with 8 push buttons, 4- position slide switch with a 7 position rotary knob. A manual siren and air horn button, and 3 traffic advisor control buttons.

### **WHELEN CORE WECANX TRAFFIC ADVISOR MODULE**

There shall be a Whelen model CTA Traffic Advisor module interfaced with the Cencom Core system.

### **SIREN SPEAKER**

## Boise Mobile Equipment

One (1) Whelen Model #SA315P siren speaker shall be provided. The 100 watt siren speaker shall be designed in a black nylon composite housing with 123 decibel rating.

### **ZONE A FRONT UPPER -- LIGHTBAR**

One (1) Whelen Cenator series WeCanx light bar shall be installed on the apparatus.

### **ZONE A -- LOWER FRONT WARNING LIGHTS**

Two (2) Whelen M6 Series Model # M6D warning light shall be provided. The warning light shall incorporate Linear Super-LED® and Smart LED® technology.

The lens/reflector assembly shall be sealed and resistant to water, moisture, dust, and other environmental conditions. The hard coated lens shall provide extended life/luster protection against UV and chemical stresses. The M6D light shall include a split design including red and white LEDs, with a clear lens.

The specified Whelen M6 lights shall be equipped with chrome plastic flange type light bezel mountings.

### **ZONE A -- LOWER FRONT WARNING LIGHTS**

Two (2) Whelen ION series lights, model TLIR shall provided. The light head shall have red LEDs.

### **ZONE B AND D-- FRONT INTERSECTION**

Two (2) Whelen M6 Series Model # M6RC warning light shall be provided. The warning light shall incorporate Linear Super-LED® and Smart LED® technology. The M6RC configuration shall consist of 18 red Super-LEDs and a clear optic polycarbonate lens.

The lens/reflector assembly shall be sealed and resistant to water, moisture, dust, and other environmental conditions. The hard coated lens shall provide extended life/luster protection against UV and chemical stresses.

The specified Whelen M6 lights shall be equipped with chrome plastic flange type light bezel mountings.

### **ZONE B AND D LOWER MID-BODY WARNING LIGHTS**

Two (2) Whelen M6 Series Model # M6RC warning light shall be provided. The warning light shall incorporate Linear Super-LED® and Smart LED® technology. The M6RC configuration shall consist of 18 red Super-LEDs and a clear optic polycarbonate lens.

The lens/reflector assembly shall be sealed and resistant to water, moisture, dust, and other environmental conditions. The hard coated lens shall provide extended life/luster protection against UV and chemical stresses.

The specified Whelen M6 lights shall be equipped with chrome plastic flange type light bezel mountings.

**ZONE B AND D-- UPPER SIDE REAR WARNING LIGHTS**

Two (2) Whelen M6 Series Model # M6RC warning light shall be provided. The warning light shall incorporate Linear Super-LED® and Smart LED® technology. The M6RC configuration shall consist of 18 red Super-LEDs and a clear optic polycarbonate lens.

The lens/reflector assembly shall be sealed and resistant to water, moisture, dust, and other environmental conditions. The hard coated lens shall provide extended life/luster protection against UV and chemical stresses.

The specified Whelen M6 lights shall be equipped with chrome plastic flange type light bezel mountings.

**ZONE C UPPER REAR**

Two (2) Whelen M6 Series Model # M6RC warning light shall be provided. The warning light shall incorporate Linear Super-LED® and Smart LED® technology. The M6RC configuration shall consist of 18 red Super-LEDs and a clear optic polycarbonate lens.

The lens/reflector assembly shall be sealed and resistant to water, moisture, dust, and other environmental conditions. The hard coated lens shall provide extended life/luster protection against UV and chemical stresses.

The specified Whelen M6 lights shall be equipped with chrome plastic flange type light bezel mountings.

**REAR TRAFFIC ADVISOR, EIGHT (8) L.E.D. LAMPS**

A Whelen TAZ86 eight lamp LINZ6 Super-LED Traffic Advisor with all amber lights shall be provided and mounted at the rear of the body. The solid state traffic advisor shall include model TACTL5 control head, or it can be directly connected to a Whelen CenCon Siren Head Controller.

**PAINT CODES/COLORS**

The apparatus shall be painted Candy Apple Red.

**BODY PAINTING SPECIFICATIONS**

All exposed surfaces shall be prepared and painted using a multi-step process to ensure a blemish-free, protective coating for the base metal materials.

All removable items, such as brackets and compartment doors, shall be removed and painted separately to insure finish paint behind them after they are reinstalled.

Due to its modular design, the apparatus body shall be completely finish painted prior to its installation on the

## **Boise Mobile Equipment**

chassis.

The body shall be sanded, and cleaned. Any imperfections or defects in the metal shall be corrected with premium body filler and then sanded smooth.

An epoxy primer shall be utilized on all painted and coated surfaces and shall prepare the metal for the final paint. The direct-to-metal primer shall be used to create a first level seal allowing secure adhesion between the base metal and the subsequent substrates.

All body and components shall then be primed, thoroughly sanded, and meticulously inspected for any imperfections; which shall be properly corrected..

All surfaces shall then be painted with a base coat of premium paint following the guidelines as established by the paint manufacturer. The body shall be painted using a single color to match the cab primary color, and then shall be buffed to a high gloss finish.

### **INTERIOR COMPARTMENT FINISH**

The interior wall, floor and ceiling surfaces of compartments shall be finished with Rust-Oleum brand Multispec color flecked paint. The final color combination shall be determined in pre-con.

The specified compartment(s) shall be coated with Hamlet Black colored Multi-Spec paint.

### **TOUCH-UP PAINT**

Touch-up paint shall be furnished with the completed truck at final delivery.

### **VALVE PAINTING**

All exposed valves shall be painted to match the color of the exterior body.

### **CHEVRON STRIPING**

The outer rear panels of the body only shall have 3M brand 6" wide reflective red and yellow striping installed over 50% of available area. The rear doors, suction doors and ladder door shall not be chevron striped.

### **STRIPING PACKAGE- SINGLE 4" STRIPE**

There shall be a single 4" reflective stripe installed one on each side of the apparatus. The stripe is limited to single color only.

### **WHEEL CHOCKS**

## Boise Mobile Equipment

Two (2) Worden brand, Model #HWC-7WH wheel chocks shall be provided.

### **5# DRY CHEMICAL FIRE EXTINGUISHER**

One (1) 5# ABC dry chemical fire extinguisher and mounting bracket shall be provided on the apparatus. The extinguisher shall have a pressure gauge and shall be filled with a dry chemical extinguishing agent.

### **HYDRAULIC JACK**

One (1) hydraulic jack shall be provided. The jack shall be designed for lifting capacity of twelve (12) tons.

### **LUG WRENCH**

There shall be one (1) lug wrench provided and shipped loose with the completed apparatus.

### **REFLECTOR**

A set of three (3) triangular reflectors shall be provided.

ITEM	QTY	DESCRIPTION	UNIT	PRICE	TOTAL
1	1	CHASSIS		1000.00	1000.00
2	1	ENGINE		1500.00	1500.00
3	1	TRANSMISSION		1200.00	1200.00
4	1	DRIVE SHAFT		800.00	800.00
5	1	AXLE ASSEMBLY		1100.00	1100.00
6	1	WHEEL ASSEMBLY		900.00	900.00
7	1	STEERING ASSEMBLY		700.00	700.00
8	1	SUSPENSION ASSEMBLY		600.00	600.00
9	1	EXHAUST SYSTEM		500.00	500.00
10	1	BRAKE SYSTEM		400.00	400.00
11	1	SEAT ASSEMBLY		300.00	300.00
12	1	DOOR ASSEMBLY		200.00	200.00
13	1	HOOD ASSEMBLY		150.00	150.00
14	1	TRUNK ASSEMBLY		100.00	100.00
15	1	WINDSHIELD		80.00	80.00
16	1	REARVIEW MIRROR		50.00	50.00
17	1	HEADLIGHT ASSEMBLY		40.00	40.00
18	1	BUMPER ASSEMBLY		30.00	30.00
19	1	WIPER ASSEMBLY		20.00	20.00
20	1	KEY		10.00	10.00
21	1	OWNER'S MANUAL		5.00	5.00
22	1	WARRANTY CARD		2.00	2.00
23	1	SALES TAX		100.00	100.00
24	1	DELIVERY CHARGE		50.00	50.00
25	1	PREPARE TO DELIVER CHARGE		25.00	25.00
26	1	SALES TAX		100.00	100.00
27	1	DELIVERY CHARGE		50.00	50.00
28	1	PREPARE TO DELIVER CHARGE		25.00	25.00
29	1	SALES TAX		100.00	100.00
30	1	DELIVERY CHARGE		50.00	50.00
31	1	PREPARE TO DELIVER CHARGE		25.00	25.00
32	1	SALES TAX		100.00	100.00
33	1	DELIVERY CHARGE		50.00	50.00
34	1	PREPARE TO DELIVER CHARGE		25.00	25.00
35	1	SALES TAX		100.00	100.00
36	1	DELIVERY CHARGE		50.00	50.00
37	1	PREPARE TO DELIVER CHARGE		25.00	25.00
38	1	SALES TAX		100.00	100.00
39	1	DELIVERY CHARGE		50.00	50.00
40	1	PREPARE TO DELIVER CHARGE		25.00	25.00
41	1	SALES TAX		100.00	100.00
42	1	DELIVERY CHARGE		50.00	50.00
43	1	PREPARE TO DELIVER CHARGE		25.00	25.00
44	1	SALES TAX		100.00	100.00
45	1	DELIVERY CHARGE		50.00	50.00
46	1	PREPARE TO DELIVER CHARGE		25.00	25.00
47	1	SALES TAX		100.00	100.00
48	1	DELIVERY CHARGE		50.00	50.00
49	1	PREPARE TO DELIVER CHARGE		25.00	25.00
50	1	SALES TAX		100.00	100.00

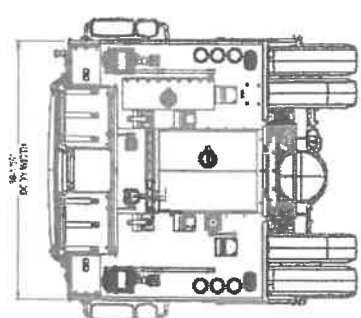
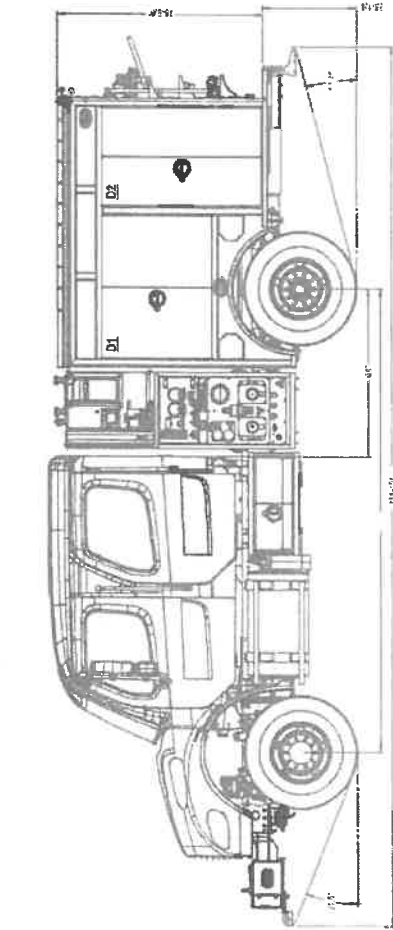
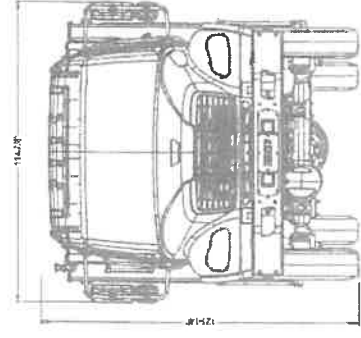
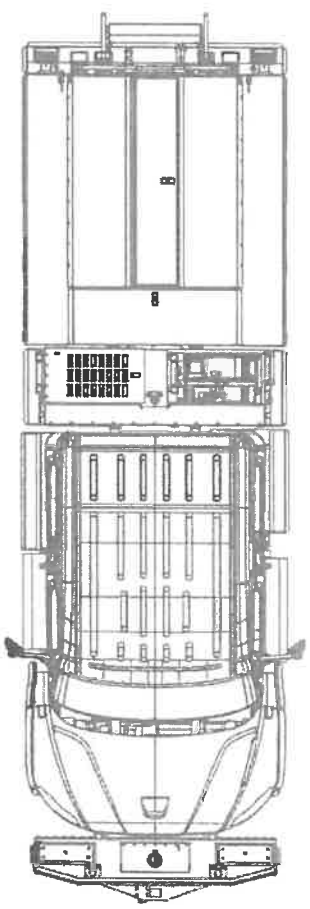
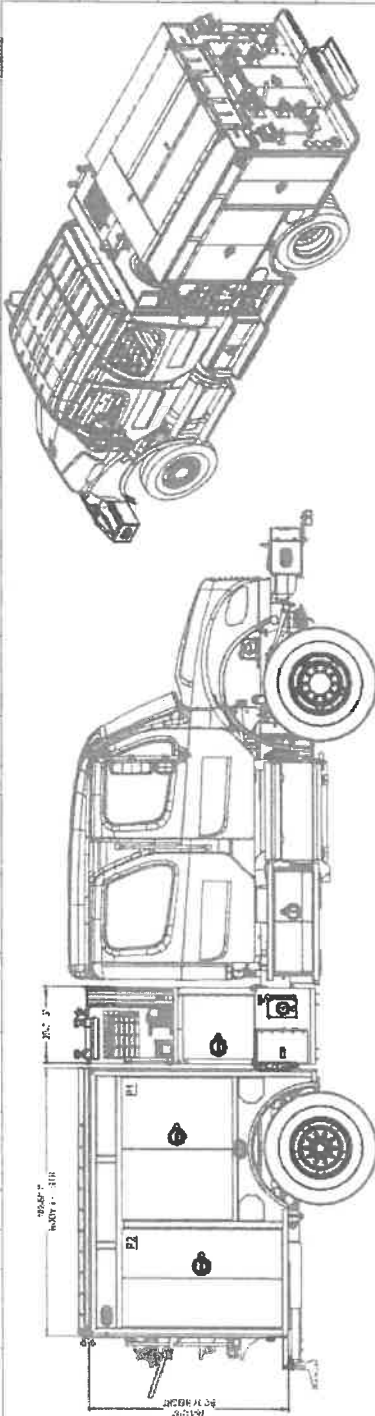

ITEM	QTY	DESCRIPTION	UNIT	PRICE	TOTAL
1	1	CHASSIS		1000.00	1000.00
2	1	ENGINE		1500.00	1500.00
3	1	TRANSMISSION		1200.00	1200.00
4	1	DRIVE SHAFT		800.00	800.00
5	1	AXLE ASSEMBLY		1100.00	1100.00
6	1	WHEEL ASSEMBLY		900.00	900.00
7	1	STEERING ASSEMBLY		700.00	700.00
8	1	SUSPENSION ASSEMBLY		600.00	600.00
9	1	EXHAUST SYSTEM		500.00	500.00
10	1	BRAKE SYSTEM		400.00	400.00
11	1	SEAT ASSEMBLY		300.00	300.00
12	1	DOOR ASSEMBLY		200.00	200.00
13	1	HOOD ASSEMBLY		150.00	150.00
14	1	TRUNK ASSEMBLY		100.00	100.00
15	1	WINDSHIELD		80.00	80.00
16	1	REARVIEW MIRROR		50.00	50.00
17	1	HEADLIGHT ASSEMBLY		40.00	40.00
18	1	BUMPER ASSEMBLY		30.00	30.00
19	1	WIPER ASSEMBLY		20.00	20.00
20	1	KEY		10.00	10.00
21	1	OWNER'S MANUAL		5.00	5.00
22	1	WARRANTY CARD		2.00	2.00
23	1	SALES TAX		100.00	100.00
24	1	DELIVERY CHARGE		50.00	50.00
25	1	PREPARE TO DELIVER CHARGE		25.00	25.00
26	1	SALES TAX		100.00	100.00
27	1	DELIVERY CHARGE		50.00	50.00
28	1	PREPARE TO DELIVER CHARGE		25.00	25.00
29	1	SALES TAX		100.00	100.00
30	1	DELIVERY CHARGE		50.00	50.00
31	1	PREPARE TO DELIVER CHARGE		25.00	25.00
32	1	SALES TAX		100.00	100.00
33	1	DELIVERY CHARGE		50.00	50.00
34	1	PREPARE TO DELIVER CHARGE		25.00	25.00
35	1	SALES TAX		100.00	100.00
36	1	DELIVERY CHARGE		50.00	50.00
37	1	PREPARE TO DELIVER CHARGE		25.00	25.00
38	1	SALES TAX		100.00	100.00
39	1	DELIVERY CHARGE		50.00	50.00
40	1	PREPARE TO DELIVER CHARGE		25.00	25.00
41	1	SALES TAX		100.00	100.00
42	1	DELIVERY CHARGE		50.00	50.00
43	1	PREPARE TO DELIVER CHARGE		25.00	25.00
44	1	SALES TAX		100.00	100.00
45	1	DELIVERY CHARGE		50.00	50.00
46	1	PREPARE TO DELIVER CHARGE		25.00	25.00
47	1	SALES TAX		100.00	100.00
48	1	DELIVERY CHARGE		50.00	50.00
49	1	PREPARE TO DELIVER CHARGE		25.00	25.00
50	1	SALES TAX		100.00	100.00



QUOTATION

**FIRE TRUCKS**

BME Fire Trucks LLC.  
 Jeff Haynes  
 4600 S Apple Street  
 Boise, Idaho 83716  
 208-853-1708

BME Fire Trucks LLC.  
 Jeff Haynes  
 4600 Apple Street  
 Boise, Idaho 83716  
 208-853-1708

Quote No: 10070-0003  
 Job/Order No: 3892  
 07/03/2024

PART NO	S	DESCRIPTION	QTY	ID
		== BME, Type 3: Model 34, 500/500 "Targhee" - 2.200 04/17/23 ==		BME
		COVER SHEET		BME
00-00-1215	XS	Commercial Wildland, Single Axle, Model 34, "Targhee"	1	BME
		GENERAL TERMS AND CONDITIONS		BME
00-01-0010		Standard Boiler Plate Package (DEALER)	1	BME
00-15-1110		-- Certificate, Weight/Tilt Angle, NFPA (BME)	1	BME
00-20-1310		-- Performance Testing, Electrical, 12 Volt (BME)	1	BME
00-21-9100		-- Test Results, Vehicle (BME)	1	BME
00-55-1010		-- Delivery, Dealer Arranged	1	BME
00-65-1020		-- Warranty, General Provisions, 1 Year (BME)	1	BME
00-65-2100		-- Material and Workmanship Rqmts (BME)	1	BME
00-66-1115		-- Warranty, Body & Structural, 10 Yrs (BME)	1	BME
00-67-1100		-- Foam Warranty, System, 1 year	1	BME
00-67-1410		-- Pump Warranty, Darley, 3 years	1	BME
00-67-1620		-- Plumbing Warranty, 10 Years, Stainless Steel	1	BME
00-67-1800		-- Valve Warranty, Akron, 10 years	1	BME
00-68-2110		-- Warranty, Foam Tank, Poly, Lifetime	1	BME
00-68-1101		-- Warranty, Water Tank, Poly, Lifetime	1	BME

PART NO	S	DESCRIPTION	QTY	ID
00-69-5210		-- Warranty, Paint, 7 yrs (BME)	1	BME
00-69-5420		-- Warranty, Lettering/Striping, 3 yrs (BME)	1	BME
00-70-1055		-- Warranty, Chassis, General (BME)	1	BME
00-75-1405		-- Manuals, Apparatus Complete Electronic, USB	2	BME
<b>===== CHASSIS SPECIFICATIONS =====</b>				<b>BME</b>
01-40-1220	XS	F-L M2 106+, 360 HP, 4 Door, Single Axle, 4x4, Model 34 <b>LABELING</b>	1	BME BME
02-71-1000		*** Cab Seating Placard ***	1	BME
02-71-1100		Label, Seating Number, Cab	1	BME
02-71-2999			1	BME
02-71-3000		*** Safety Placards ***	1	BME
02-71-3100		Labels, Standard Package Set	1	BME
02-71-3110		-- Label, Data, Fluid Levels	1	BME
02-71-3115		-- Label, Data, Pump Performance	1	BME
02-71-3300		-- Label, Data, "No Ride" Rear Step (LEXAN)	1	BME
02-71-3400		-- Label, Data, Seat Belt	1	BME
02-71-3700		-- Label, Noise Danger, Personnel	1	BME
02-71-3900		-- Label, Ember Separator	1	BME
02-71-3910		-- Label, Ember Separator, Fresh Air	1	BME
02-71-3920		-- Label, Data, Do Not Wear Helmet While Seated	1	BME
<b>LOGOS -- BME</b>				<b>BME</b>
02-71-4110		Plaque, BME (1)	1	BME
81-15-1605		-- BME Plaque, Reflective Background, White Back, Red Front	1	BME
<b>TOWING</b>				<b>BME</b>
02-72-4002		*** Front Towing Devices ***	1	BME
02-72-4400		Tow Eye Plate, Front, Painted (Durabak) M34 - style	1	BME
02-72-5105		-- Front Receiver, Off Center	1	BME
02-72-5999			1	BME
02-72-6000		*** Rear Towing Provisions ***	1	BME
02-72-7105		Rear Receiver, Off Center	1	BME
02-72-8300		Towing Provision, Rear Under Body Bustle, Job Color, Model 34	1	BME
<b>BUMPERS</b>				<b>BME</b>
02-73-1000		*** Bumper Extensions ***	1	BME
02-73-1240		Bumper Extension, 16", Frame Rails	1	BME
02-73-1220		-- Bumper Platform, 16", .125" Alum NFPA T/P	1	BME
02-73-8005		-- Bumper, International, 15 degree	1	BME
02-73-9701		-- Front Bumper, Color, Job Color	1	BME

PART NO	S	DESCRIPTION	QTY	ID
02-73-8008		-- Bumper, Side Bumper Wings	1	BME
02-73-9710		-- Front Bumper, Wings, Color, Job Color	1	BME
02-73-1600		Bumper Replacement, Freightliner to Navistar	1	BME
02-73-1999			1	BME
02-73-2000		*** Bumper Compartments ***	1	BME
02-73-2305		Bumper Cmpt, Driver, Hose Stge Compartment	1	BME
02-73-6600		-- Bumper Cmpt, Nylon Straps W/Buckles, (1) per Cmpt	1	BME
35-86-1100		-- Black Straps	1	BME
35-85-2118		-- Dri-Dek, Grating, Per Bumper Cmpt	1	BME
35-85-5001		-- Dri-Dek, Black	1	BME
02-73-2999			1	BME
02-73-3305		Bumper Cmpt, Center, Hose Stge Compartment	1	BME
02-73-6100		-- Bumper Cmpt, Door, Alum T/P, ALDP	1	BME
24-18-2310		-- D-ring, Polished	1	BME
35-85-2118		-- Dri-Dek, Grating, Per Bumper Cmpt	1	BME
35-85-5001		-- Dri-Dek, Black	1	BME
02-73-3999			1	BME
02-73-4305		Bumper Cmpt, Psngr, Hose Stge Compartment	1	BME
02-73-6600		-- Bumper Cmpt, Nylon Straps W/Buckles, (1) per Cmpt	1	BME
35-86-1100		-- Black Straps	1	BME
35-85-2118		-- Dri-Dek, Grating, Per Bumper Cmpt	1	BME
35-85-5001		-- Dri-Dek, Black	1	BME
02-73-6999			1	BME
02-73-8000		*** Bumper Equipment ***	1	BME
02-73-8006		Bumper, Swivel Elbow Stopper	1	BME
02-73-9501	XS	Front Bumper, Center Bezel, BME, Whelen Light Cutout, Tow Plate	1	BME
81-15-1501	XS	-- Reflective Background, Red	1	BME
<b>AIR HORNS</b>				<b>BME</b>
02-74-1560		Air Horn, (1) Buell, #1063, Frame Mounted, (Model 34)	1	BME
02-74-2200		-- Air Horn, Control, Driver, Single Foot Switch	1	BME
02-74-2520		-- Air Horn, Control, Pump Panel	1	BME
<b>EXHAUST SYSTEMS</b>				<b>BME</b>
02-76-1000		*** Horizontal Exhaust ***	1	BME
02-76-1100		Exhaust System, Extend to Psngr Side	1	BME
02-76-1350		Exhaust, Heat Wrap	1	BME
<b>MUD FLAPS</b>				<b>BME</b>
02-77-1000		*** Front Mud Flaps ***	1	BME
02-77-1600		Bumper Box Protective Flaps, Black Rubber	1	BME
02-77-1999			1	BME

PART NO	S	DESCRIPTION	QTY	ID
02-77-2000		*** Rear Mud Flaps ***	1	BME
02-77-2200		Mud Flaps, Rear Wheels, Manufacturer Logo	1	BME
<b>CAB STEPS -- ALUM T/P ENCLOSURES -- SCUFF PLATES</b>				<b>BME</b>
02-79-2000		*** Cab Step Compartments ***	1	BME
02-79-2060		Cab Step Compartment, Under Cab, Driver, S.S., Double door	1	BME
02-79-3220		-- Slide Tray, 500#, Under Cab Compartment, Aluminum, W/Dividers	1	BME
41-44-4020		-- Cmpt Lights, 800 Series Corner LED 21"	1	BME
41-46-1005		-- Cmpt Light Door Switch, Automatic, Cmpt Door	1	BME
02-79-2109			1	BME
02-79-2160		Cab Step Compartment, Under Cab, Psngr, S.S., Double Door	1	BME
02-79-3100	XS	-- Slide Tray, 250#, Under Cab Compartment, S/S	1	BME
41-44-4020		-- Cmpt Lights, 800 Series Corner LED 21"	1	BME
41-46-1005		-- Cmpt Light Door Switch, Automatic, Cmpt Door	1	BME
02-79-3999			1	BME
02-79-4000		*** Cab Steps ***	1	BME
02-79-4500		Cab Steps, Extrd Diamond Back Alum, (4) Door	1	BME
<b>CAB DOORS</b>				<b>BME</b>
02-80-1600		Cab Trim, Door, Reflective NFPA, 4 Door	1	BME
81-15-1521		-- Reflective Color, Red/Wht DOT	1	BME
<b>CAB SEATING AND SCBA EQUIPMENT</b>				<b>BME</b>
02-81-0100		NO--Seats, Front, Chassis Mfgr Supplied	1	BME
<b>AIR SYSTEMS</b>				<b>BME</b>
02-87-2200		Air Outlet, Pump Panel, Manual, Drivers Pnl, W/Shutoff at Tank	1	BME
02-87-2705		Air Tank Relocation, Rear	1	BME
<b>ADDITIONAL CHASSIS MODIFICATIONS</b>				<b>BME</b>
02-88-2125		Chassis Batteries, Relocated, Model 34	1	BME
02-88-2199			1	BME
02-88-2500		Under hood Light, LED	2	BME
02-88-4100		Ember Separator, Screen, Installation, Chassis Engine	1	BME
02-88-4200		Ember Separator, Screen, Installation, Fresh Air Cab	1	BME
02-88-4300		Ember Separator, Screen, Installation, Fire Pump Engine, Aux	1	BME
02-88-4399			1	BME
02-88-5330		Fuel Tank Skid Plate	1	BME
02-88-5399			1	BME
02-88-7100		Protective Sleeve, Air, Fuel, Elec Lines, Fire Resistant Sleeves	1	BME
02-88-7110		Fuel Tank Venting	1	BME
02-88-7999			1	BME

PART NO	S	DESCRIPTION	QTY	ID
02-88-8100		Tire Pressure Monitoring System, Real Wheels	1	BME
		***** FIRE PUMP *****		BME
08-11-1200		Pump, Darley, JMP500, 2/Stg, PTO, (Model 34)	1	BME
08-20-2500		-- Pump Seal, Mechanical, Darley, PTO	1	BME
08-20-3420		-- Pump Shift, Darley, PTO, JMP, NO Pump and Roll, Stationary Pumping Only	1	BME
08-20-5100		-- Anode, Pump, Darley	1	BME
08-20-6005		-- Pump Primer, Darley, Elec	1	BME
10-01-1410		-- Pump Test, NFPA, 1906, Factory Test	1	BME
10-02-1100		-- Pump Drive, PTO and Drivelines, Chelsea (Transmission mounted)	1	BME
10-03-1150		-- Intake-Relief Valve, Elkhart #40/40	1	BME
10-04-1120		-- Pump Cooler, Bypass-To-Tank, 3/8"	1	BME
10-04-1600		-- Waterous, Thermal Bypass, Overheat Protection Manager	1	BME
10-06-1200		-- Pump Drain, Master-Low Point, Handwheel	1	BME
10-09-1100		-- Piping, Stainless Steel, PTO, <500GPM	1	BME
08-12-9999			1	BME
08-15-1800		Pump, Darley, 1-1/2 AGE, 24HP Kubota D902 Diesel, Model 34	1	BME
08-20-5300		-- Dual Deluxe Plus Panels, Darley	1	BME
10-09-1300		-- Piping, Stainless Steel, Auxiliary Pump	1	BME
10-80-2100		-- Exhaust and Muffler, Aux Pump	1	BME
10-80-3115		-- Primer, Electric, Share with Main Pump, Aux Control Panel, Push Button	1	BME
10-80-4400		-- Shut Down Pump, Low Pressure, 20 PSI	1	BME
10-80-4410		-- Shut Down Pump, Low Oil Pressure/High Engine Temp	1	BME
10-80-5300		-- Fuel System, Plumbed to Chassis Fuel Tank	1	BME
10-80-6100		-- Battery, 12V, From Chassis, Quick Disconnect	1	BME
10-81-6100		-- Plumbing, Piped to Main Fire Pump	1	BME
10-81-8400		-- Auxiliary Pump, Oil Drain Extension	1	BME
		===== PUMP INTAKES =====		BME
		LEFT SIDE INTAKE		BME
11-01-1000		*** Left Side Ungated Intakes ***	1	BME
11-01-1300		Intake, Ungated, 4", LH Side	1	BME
11-07-3300		-- Cap, 4", Chrome Brass, Rocker Lug	1	BME
11-01-1799			1	BME
11-01-2000		*** Left Side Gated Intakes ***	1	BME
11-01-2100		Intake, Gated, 2.5", LH Side	1	BME
10-07-1105		-- Intake Valve Bleeder, South Park, W/O flange, Push-Pull	1	BME
10-15-1120		-- Valves, Akron, Brass, 8825 Series (Uses R1,TS or TSC Handles Only)	1	BME
10-20-0060		-- Valve, Direct, Local Control, Akron locking TSC	1	BME
11-07-1100		-- Plug, 2.5", Chrome Brass, Rocker Lug	1	BME

PART NO	S	DESCRIPTION	QTY	ID
<b>RIGHT SIDE INTAKE</b>				<b>BME</b>
11-02-3000		*** Right Side Gated Intakes ***	1	BME
11-02-3100		Intake, Gated, 2.5", RH Side	1	BME
10-07-1105		-- Intake Valve Bleeder, South Park, W/O flange, Push-Pull	1	BME
10-15-1120		-- Valves, Akron, Brass, 8825 Series (Uses R1,TS or TSC Handles Only)	1	BME
10-20-0060		-- Valve, Direct, Local Control, Akron locking TSC	1	BME
11-07-1100		-- Plug, 2.5", Chrome Brass, Rocker Lug	1	BME
<b>TANK-TO-PUMP</b>				<b>BME</b>
11-10-2000		*** Tank To Pump - PTO Pumps ***	1	BME
11-10-2300		Tank-To-Pump, 3", W/Check Valve	1	BME
10-15-1230		-- Valve, Akron Brass, 8830 Series, (Tank to Pump)	1	BME
10-20-0040		-- Valves, Direct, R1, Handle	1	BME
10-23-1400		-- Air Operated Valve Cntrl, 3"	1	BME
<b>PUMP-TO-TANK</b>				<b>BME</b>
11-20-2200		Pump-To-Tank, 2", Water Tank, (Model 34)	1	BME
10-15-1220		-- Valve, Akron Brass, 8820 Series (Pump to Tank)	1	BME
10-20-0040		-- Valves, Direct, R1, Handle	1	BME
10-20-1110		-- Pull Rod Valve Cntrl, Thuemling, Locking	1	BME
<b>LEFT SIDE DISCHARGES</b>				<b>BME</b>
12-05-1000		*** 2.5" Left Side Discharges ***	1	BME
12-05-1120		Discharge, 2.5", LH Forward	1	BME
10-08-1100		-- Discharge Valve Bleeder, Class 1, Manual 1/4 Turn	1	BME
10-15-1120		-- Valves, Akron, Brass, 8825 Series (Uses R1,TS or TSC Handles Only)	1	BME
10-20-0060		-- Valve, Direct, Local Control, Akron locking TSC	1	BME
12-22-4100		-- Cap, 2.5", Rocker Lug, Chrome Brass, w/Chain	1	BME
14-31-1055		-- Line Pressure Gauge, SPAN, 2.5"	1	BME
14-30-1400		-- Pressure Gauge, Drains	1	BME
14-30-4100		-- Gauge Backlighting, LED, White	1	BME
14-30-4600		-- Standard Dial Face, Black on White	1	BME
14-30-5100		-- Gauge Bezel, Chrome	1	BME
<b>===== REAR DISCHARGES =====</b>				<b>BME</b>
12-07-2000		*** 2.5" Rear Left Discharges ***	1	BME
12-07-2100		Discharge, 2.5", Rear LH	1	BME
10-15-1120		-- Valves, Akron, Brass, 8825 Series (Uses R1,TS or TSC Handles Only)	1	BME

PART NO	S	DESCRIPTION	QTY	ID
10-20-0060		-- Valve, Direct, Local Control, Akron locking TSC	1	BME
12-20-1050		-- NO--Reducing Adapter	1	BME
12-21-1200		-- Elbow, 2.5"F x 2.5"M, Chrome Brass	1	BME
12-22-4100		-- Cap, 2.5", Rocker Lug, Chrome Brass, w/Chain	1	BME
12-08-0299			1	BME
12-08-1000		*** 2" Rear Right Discharges ***	1	BME
12-08-1100		Discharge, 2" x 1.5", Rear RH	1	BME
10-15-1115		-- Valves, Akron, Brass, 8820 Series (Uses R1,TS or TSC Handles Only)	1	BME
10-20-0060		-- Valve, Direct, Local Control, Akron locking TSC	1	BME
12-20-1150		-- Reducing Adapter, 2"F x 1.5"M, Chrome Brass	1	BME
12-21-1100		-- Elbow, 1.5"F x 1.5"M, Chrome Brass	1	BME
12-22-2100		-- Cap, 1.5", Rocker Lug, Chrome Brass, w/Chain	1	BME
		<b>1-1/2" / 2" CROSSLAY DISCHARGES</b>		<b>BME</b>
12-10-1056		Crosslay Discharge, (2) 1-1/2", Over Pump Panel (Model 34)	1	BME
10-15-1115		-- Valves, Akron, Brass, 8820 Series (Uses R1,TS or TSC Handles Only)	2	BME
10-20-0060		-- Valve, Direct, Local Control, Akron locking TSC	2	BME
12-11-5150		-- Crosslay Cover, Alum T/P, Vinyl NFPA Ends	1	BME
12-11-7310		-- Crosslay Flaps, Vinyl, Red	2	BME
12-11-6110		-- Crosslay Flared Edges, Both Sides	1	BME
12-20-1150		-- Reducing Adapter, 2"F x 1.5"M, Chrome Brass	2	BME
12-22-2100		-- Cap, 1.5", Rocker Lug, Chrome Brass, w/Chain	2	BME
		<b>FRONT BUMPER DISCHARGES</b>		<b>BME</b>
12-13-1210		Bumper Dschrg, 2" Valve, 1-1/2" Front, Swivel, Left Side	1	BME
10-15-1115		-- Valves, Akron, Brass, 8820 Series (Uses R1,TS or TSC Handles Only)	1	BME
10-20-0060		-- Valve, Direct, Local Control, Akron locking TSC	1	BME
12-22-2100		-- Cap, 1.5", Rocker Lug, Chrome Brass, w/Chain	1	BME
12-13-1299			1	BME
12-13-1310		Bumper Dschrg, 2" Valve, 1-1/2" Front, Swivel, Right Side	1	BME
10-15-1115		-- Valves, Akron, Brass, 8820 Series (Uses R1,TS or TSC Handles Only)	1	BME
10-20-0060		-- Valve, Direct, Local Control, Akron locking TSC	1	BME
12-22-2100		-- Cap, 1.5", Rocker Lug, Chrome Brass, w/Chain	1	BME
12-13-1359			1	BME
12-13-1360		Discharge Isolation Vlv Cntrl, 2", Wildland,	1	BME
10-15-1700		-- Valves, Akron, Brass, 8820 Series, Isolation Valve	1	BME
10-20-0040		-- Valves, Direct, R1, Handle	1	BME
		<b>HOSE REELS</b>		<b>BME</b>
12-31-2205		Hose Reel, HANNAY, Elec Rewind, Super Booster (Model 34)	1	BME

PART NO	S	DESCRIPTION	QTY	ID
10-15-1105		-- Valves, Akron, Brass, 8810 Series (Uses R1, TS or TSC Handles Only)	1	BME
10-20-0060		-- Valve, Direct, Local Control, Akron locking TSC	1	BME
12-31-3100		-- Mounting Hose Reel, Over Pump Area	1	BME
12-32-2110		-- Rewind Cntrl, Weatherproof Push Buttons, Model 34	2	BME
12-32-6700		-- Rollers, Hose Reel, Model 34	1	BME
<b>INJECTION - FOAM SYSTEMS</b>				<b>BME</b>
13-10-1120		Foam System, FoamPro, 1600 12V Elec, Model 34	1	BME
13-10-5200		-- Foam System, FoamPro, On-Off Switch in Cab	1	BME
13-11-1110		-- Foam Upload System, Hale, EZ Foam	1	BME
<b>===== PUMP ENCLOSURES =====</b>				<b>BME</b>
14-01-2140		Pump Enc, PTO, Steel, 27"W, Model 34	1	BME
10-81-8800		-- Auxiliary Pump, Cover, ALDP	1	BME
41-46-2005		-- Door Open Sensor, Compt Door	1	BME
<b>PUMP ENCLOSURE STEPS</b>				<b>BME</b>
14-15-1225	XS	Running Boards, Pump Panel, Non-slip, Driver/Passenger	1	BME
<b>PUMP ENCLOSURE SERVICE ACCESS DOORS</b>				<b>BME</b>
14-16-1100		Pump Enc Door, Upper LH, S/S, Blk Powder Coated, Model 34	1	BME
<b>PUMP PANELS</b>				<b>BME</b>
14-25-1100		Pump Panels, SM, Stainless Steel, Blk Powder Coated, Model 34	1	BME
<b>PUMP PANEL INSTRUMENTATION</b>				<b>BME</b>
14-30-1300		Master Discharge Pressure / Intake Pressure Gauges, SPAN, 4.5"	1	BME
14-30-1500		-- *** 4.5" Master Pressure Gauges - Intake***	1	BME
14-30-1600		-- Master Intake Pressure Gauge, SPAN, 30-0-150	1	BME
14-30-1400		-- Pressure Gauge, Drains	1	BME
14-30-4100		-- Gauge Backlighting, LED, White	1	BME
14-30-4600		-- Standard Dial Face, Black on White	1	BME
14-30-5100		-- Gauge Bezel, Chrome	1	BME
14-30-1999		--	1	BME
14-30-2000		-- *** 4.5" Master Pressure Gauges - Discharge***	1	BME
14-30-2300		-- Master Discharge Pressure Gauge, SPAN, 0-600	1	BME
14-30-4100		-- Gauge Backlighting, LED, White	1	BME
14-30-4600		-- Standard Dial Face, Black on White	1	BME
14-30-5100		-- Gauge Bezel, Chrome	1	BME
14-30-2999		--	1	BME

PART NO	S	DESCRIPTION	QTY	ID
14-30-3000		-- *** Test Taps - Pressure Gauges ***	1	BME
14-30-3100		-- Gauge, Test Taps	1	BME
<b>ENGINE CONTROLS AND GAUGES</b>				<b>BME</b>
14-35-2130		Pressure Governor, FRC, PBA401-D00, Pump Boss (Cummins)	1	BME
<b>WATER TANK LEVEL GAUGES</b>				<b>BME</b>
14-40-1100		Water Tank Gauge, FRC, TankVision, Pump Panel	1	BME
14-40-4215		-- Level Gauge, Activation, Battery Switched	1	BME
14-40-1115		Water Tank Gauge, FRC, TankVision, Console	1	BME
14-40-1400		Water Tank Gauge, FRC, TankVision, MaxVision	2	BME
14-40-4215		-- Level Gauge, Activation, Battery Switched	2	BME
<b>FOAM TANK LEVEL GAUGES</b>				<b>BME</b>
14-40-5100		Foam Tank Gauge, FRC, Class A, Pump Panel	1	BME
14-40-4215		-- Level Gauge, Activation, Battery Switched	1	BME
<b>LABELING AND LIGHTING</b>				<b>BME</b>
14-45-1000		*** Identification Labels ***	1	BME
14-45-1210		Nomenclature Plates, Color Coded, English, Lexan w/Bezel	1	BME
14-45-1999			1	BME
14-45-2000		*** Pump Panel and Pump Enclosure Lighting ***	1	BME
14-45-2155		Pump Panel Light, Midship, Driver, LED, Tecniq, 3 Lights	1	BME
14-45-3000		-- Pump Panel Light, Actuated Pump Engagement	1	BME
14-45-2199			1	BME
14-45-2255		Pump Panel Light, Midship Psngr, LED, Tecniq, 1 Light	1	BME
14-45-2999			1	BME
14-45-3210		Pump Enc Lights, Plumbing Area, Manual Switch, Tecniq E10	1	BME
<b>PUMP PANEL EQUIPMENT</b>				<b>BME</b>
<b>----- STEEL BODY CONSTRUCTION -----</b>				<b>BME</b>
20-10-2125		Body Constrc, Steel, Gnrl Design, Wildland, Targhee	1	BME
20-12-1100		-- Body Sub-structure Steel, Pumper	1	BME
20-13-1100		-- Frame Mounting, Steel Body, Pumper	1	BME
20-14-1110		-- Compartment Constrc, Steel, Sweep-Out Floors	1	BME
20-14-1200		-- Exterior Sheet Metal Body Fabrication, Steel, Pumper	1	BME
20-14-1300		-- Interior Sheet Metal, Body Construction, Steel, Pumper	1	BME
<b>***** Model 34 - Targhee Compartments *****</b>				<b>BME</b>

PART NO	S	DESCRIPTION	QTY	ID
21-01-2701		*** Drivers Side Compartments ***	1	BME
21-01-2720		Cmpt Dim, Drivers, 51"W x 39"H, D1	1	BME
24-09-1200		-- Ventilation and Filter, Weber Style, Compartment	1	BME
24-09-3100		-- Cmpt Floor Drains, Corners, Each	1	BME
24-17-5100		-- Cmpt, Sill Plate, Polished Stainless Steel, Each	1	BME
35-01-1110		-- Adj tracks, Uni-Strut	1	BME
35-01-7120		-- Adj tracks, Uni-Strut, Back Wall, Vertical (2)	1	BME
35-10-0155		-- Shelf, Adjustable, Alum 1/8"	1	BME
35-85-2115		-- Dri-Dek, Grating, Per Cmpt Shelf	1	BME
35-85-5001		-- Dri-Dek, Black	1	BME
81-20-2510		-- Stripe, Shelves, Reflective	1	BME
81-15-1521		-- Reflective Color, Red/Wht DOT	1	BME
35-20-0050		-- NO--Slide Tray	1	BME
35-45-1000		-- NO-- Vertical Divider	1	BME
35-50-6005		-- NO--Tool Board, Rear Wall	1	BME
35-50-6010		-- NO--Tool Board, Side Walls	1	BME
35-70-3201		-- NO--SCBA Mounting	1	BME
35-85-2110		-- Dri-Dek, Grating, Per Cmpt Surface	1	BME
35-85-2120		-- Dri-Dek, Grating, Edging, Per Cmpt	1	BME
35-85-5001		-- Dri-Dek, Black	1	BME
41-45-0015		-- Compartment Lighting, Code 3 800 series, (3)	1	BME
41-46-2005		-- Door Open Sensor, Cmpt Door	1	BME
42-20-1050		-- NO - 12V Power	1	BME
21-01-2725			1	BME
21-01-2740		Cmpt Dim, Drivers, 34"W x 58"H, D2	1	BME
24-09-1200		-- Ventilation and Filter, Weber Style, Compartment	1	BME
24-09-3100		-- Cmpt Floor Drains, Corners, Each	1	BME
24-17-5100		-- Cmpt, Sill Plate, Polished Stainless Steel, Each	1	BME
35-01-1110		-- Adj tracks, Uni-Strut	1	BME
35-01-7120		-- Adj tracks, Uni-Strut, Back Wall, Vertical (2)	1	BME
35-10-0155		-- Shelf, Adjustable, Alum 1/8"	1	BME
35-85-2115		-- Dri-Dek, Grating, Per Cmpt Shelf	1	BME
35-85-5001		-- Dri-Dek, Black	1	BME
81-20-2510		-- Stripe, Shelves, Reflective	1	BME
81-15-1521		-- Reflective Color, Red/Wht DOT	1	BME
35-20-0050		-- NO--Slide Tray	1	BME
35-45-1000		-- NO-- Vertical Divider	1	BME
35-50-6005		-- NO--Tool Board, Rear Wall	1	BME
35-50-6010		-- NO--Tool Board, Side Walls	1	BME
35-54-1050		-- NO-- Slide Out Vertical Tool Boards	1	BME
35-85-2110		-- Dri-Dek, Grating, Per Cmpt Surface	1	BME
35-85-2120		-- Dri-Dek, Grating, Edging, Per Cmpt	1	BME
35-85-5001		-- Dri-Dek, Black	1	BME
41-45-0015		-- Compartment Lighting, Code 3 800 series, (3)	1	BME
41-46-2005		-- Door Open Sensor, Cmpt Door	1	BME
42-20-1050		-- NO - 12V Power	1	BME

PART NO	S	DESCRIPTION	QTY	ID
21-01-2799			1	BME
21-01-2800		*** Passenger Side Compartments ***	1	BME
21-01-2811		Cmpt Dim, Psngr, 51"W x 39"H, P1	1	BME
24-09-1200		-- Ventilation and Filter, Weber Style, Compartment	1	BME
24-09-3100		-- Cmpt Floor Drains, Corners, Each	1	BME
24-17-5100		-- Cmpt, Sill Plate, Polished Stainless Steel, Each	1	BME
35-01-1110		-- Adj tracks, Uni-Strut	1	BME
35-01-7120		-- Adj tracks, Uni-Strut, Back Wall, Vertical (2)	1	BME
35-10-0155		-- Shelf, Adjustable, Alum 1/8"	1	BME
35-85-2115		-- Dri-Dek, Grating, Per Cmpt Shelf	1	BME
35-85-5001		-- Dri-Dek, Black	1	BME
81-20-2510		-- Stripe, Shelves, Reflective	1	BME
81-15-1521		-- Reflective Color, Red/Wht DOT	1	BME
35-20-0050		-- NO--Slide Tray	1	BME
35-45-1000		-- NO-- Vertical Divider	1	BME
35-50-6005		-- NO--Tool Board, Rear Wall	1	BME
35-50-6010		-- NO--Tool Board, Side Walls	1	BME
35-70-3201		-- NO--SCBA Mounting	1	BME
35-85-2110		-- Dri-Dek, Grating, Per Cmpt Surface	1	BME
35-85-2120		-- Dri-Dek, Grating, Edging, Per Cmpt	1	BME
35-85-5001		-- Dri-Dek, Black	1	BME
41-45-0015		-- Compartment Lighting, Code 3 800 series, (3)	1	BME
41-46-2005		-- Door Open Sensor, Cmpt Door	1	BME
42-20-1050		-- NO - 12V Power	1	BME
21-01-2815			1	BME
21-01-2831		Cmpt Dim, Psngr, 34"W x 58"H, P2	1	BME
24-09-1200		-- Ventilation and Filter, Weber Style, Compartment	1	BME
24-09-3100		-- Cmpt Floor Drains, Corners, Each	1	BME
24-17-5100		-- Cmpt, Sill Plate, Polished Stainless Steel, Each	1	BME
35-01-1110		-- Adj tracks, Uni-Strut	1	BME
35-01-7120		-- Adj tracks, Uni-Strut, Back Wall, Vertical (2)	1	BME
35-10-0155		-- Shelf, Adjustable, Alum 1/8"	1	BME
35-85-2115		-- Dri-Dek, Grating, Per Cmpt Shelf	1	BME
35-85-5001		-- Dri-Dek, Black	1	BME
81-20-2510		-- Stripe, Shelves, Reflective	1	BME
81-15-1521		-- Reflective Color, Red/Wht DOT	1	BME
35-20-0050		-- NO--Slide Tray	1	BME
35-45-1000		-- NO-- Vertical Divider	1	BME
35-50-6005		-- NO--Tool Board, Rear Wall	1	BME
35-50-6010		-- NO--Tool Board, Side Walls	1	BME
35-54-1050		-- NO-- Slide Out Vertical Tool Boards	1	BME
35-85-2110		-- Dri-Dek, Grating, Per Cmpt Surface	1	BME
35-85-2120		-- Dri-Dek, Grating, Edging, Per Cmpt	1	BME
35-85-5001		-- Dri-Dek, Black	1	BME
41-45-0015		-- Compartment Lighting, Code 3 800 series, (3)	1	BME
41-46-2005		-- Door Open Sensor, Cmpt Door	1	BME
42-20-1050		-- NO - 12V Power	1	BME

PART NO	S	DESCRIPTION	QTY	ID
21-01-2839			1	BME
21-01-2840		*** Back Compartments ***	1	BME
21-01-2841		Back Compartment, 27"W x 34"H, B1	1	BME
24-09-1200		-- Ventilation and Filter, Weber Style, Compartment	1	BME
24-09-3100		-- Cmpt Floor Drains, Corners, Each	1	BME
24-17-5100		-- Cmpt, Sill Plate, Polished Stainless Steel, Each	1	BME
35-01-1110		-- Adj tracks, Uni-Strut	1	BME
35-01-7105		-- Adj tracks, Uni-Strut, Back Wall, (2), Horizontal	1	BME
35-10-0155		-- Shelf, Adjustable, Alum 1/8"	1	BME
35-85-2115		-- Dri-Dek, Grating, Per Cmpt Shelf	1	BME
35-85-5001		-- Dri-Dek, Black	1	BME
81-20-2510		-- Stripe, Shelves, Reflective	1	BME
81-15-1521		-- Reflective Color, Red/Wht DOT	1	BME
35-20-0050		-- NO--Slide Tray	1	BME
35-85-2110		-- Dri-Dek, Grating, Per Cmpt Surface	1	BME
35-85-2120		-- Dri-Dek, Grating, Edging, Per Cmpt	1	BME
35-85-5001		-- Dri-Dek, Black	1	BME
41-45-0010		-- Compartment Lighting, Vertical, Code 3 800 series, (Large) (2)	1	BME
41-46-2005		-- Door Open Sensor, Cmpt Door	1	BME
42-20-1050		-- NO - 12V Power	1	BME
21-01-2860		*** Special Compartments ***	1	BME
21-01-2880		Pump House Cmpt, 21"W x 23"H x 12"D, PH1	1	BME
24-09-1200		-- Ventilation and Filter, Weber Style, Compartment	1	BME
24-09-3100		-- Cmpt Floor Drains, Corners, Each	1	BME
35-01-1110		-- Adj tracks, Uni-Strut	1	BME
35-10-0155		-- Shelf, Adjustable, Alum 1/8"	1	BME
35-85-2115		-- Dri-Dek, Grating, Per Cmpt Shelf	1	BME
35-85-5001		-- Dri-Dek, Black	1	BME
81-20-2510		-- Stripe, Shelves, Reflective	1	BME
81-15-1521		-- Reflective Color, Red/Wht DOT	1	BME
35-85-2110		-- Dri-Dek, Grating, Per Cmpt Surface	1	BME
35-85-2120		-- Dri-Dek, Grating, Edging, Per Cmpt	1	BME
35-85-5001		-- Dri-Dek, Black	1	BME
41-45-0011		-- Compartment Lighting, Two, Vertical, Code 3 800 series, (Small)	1	BME
41-46-2005		-- Door Open Sensor, Cmpt Door	1	BME
21-01-2885		Pump House Cmpt, 11.5"W x 18"H x 18"D, PH2	1	BME
24-09-3100		-- Cmpt Floor Drains, Corners, Each	1	BME
41-46-2005		-- Door Open Sensor, Cmpt Door	1	BME
		<b>SLIDE-IN LADDER CMPTS</b>		<b>BME</b>
23-68-5715		Ladder Cmpt, Vertical, 20' 3 Section, Rear, Psngr, (M34 2021)	1	BME
41-46-2005		-- Door Open Sensor, Cmpt Door	1	BME
		<b>SLIDE-IN SUCTION HOSE CMPTS</b>		<b>BME</b>

PART NO	S	DESCRIPTION	QTY	ID
23-68-6002		*** Hard Suction Hose Cmpt - Slide-in Rear ***	1	BME
23-68-6115		Hard Suction Cmpt, Rear, Drivers/Psngr, M34 2021	1	BME
41-46-2005		-- Door Open Sensor, Compt Door	2	BME
<b>HOSE BED COMPARTMENTS</b>				<b>BME</b>
23-72-4000		*** Hose Bed Dunnage Compartments --Center ***	1	BME
23-72-4100		Top Compartment, Center, (Model 34), TC1	1	BME
24-14-1001		-- Doors, Roof Compts, Lift Up Alum T/P, Small <1000sq.in	1	BME
24-19-0100		-- Lever Latch, Black, Non-Locking, Round Button, Each	1	BME
41-45-0005		-- NO--Compartment Lighting	1	BME
41-46-2005		-- Door Open Sensor, Compt Door	1	BME
23-72-4105		Top Compt, Painted Smooth Alum, Bolted Panel, Rear Upper Center	1	BME
<b>===== BODY COMPONENTS</b>				<b>BME</b>
<b>=====</b>				
<b>WHEEL WELL AREA</b>				<b>BME</b>
24-01-1100		*** Wheel Well Panels -- Single Axle ***	1	BME
24-01-1400		Wheel Well Panel Constr, Galv Steel Body, Pntd	1	BME
24-03-1999			1	BME
24-03-2000		*** Wheel Well Liners ***	1	BME
24-03-2400		Wheel Well Inner Liners, Body, Plastic, 22.5" rims, S/A	1	BME
24-03-2999			1	BME
24-03-3000		*** Fenderettes ***	1	BME
24-03-4100		Fenderettes, Body, Polished S/S, 22.5" rims (2) Single Axle	1	BME
<b>DRIVERS SIDE -- SCBA OPENINGS AND COMPARTMENTS</b>				<b>BME</b>
24-05-1700		SCBA Stge, Drivers, Fwd Wheelwell, 8" Round	1	BME
24-05-2450		-- SCBA Door, Cast Products, Lever Latch	1	BME
24-05-2500		-- SCBA Tube, Plastic, w/ Mat	1	BME
24-19-0415		-- Lever Latch, Textured Chrome Raised Button, Non-locking, Each	1	BME
24-05-7000		-- SCBA Cylinder Tether, 1" Nylon	1	BME
24-05-2300		SCBA Stge, Drivers, Rear Wheelwell, 8" Round	1	BME
24-05-2450		-- SCBA Door, Cast Products, Lever Latch	1	BME
24-05-2500		-- SCBA Tube, Plastic, w/ Mat	1	BME
24-19-0415		-- Lever Latch, Textured Chrome Raised Button, Non-locking, Each	1	BME
24-05-7000		-- SCBA Cylinder Tether, 1" Nylon	1	BME
<b>PASSENGER SIDE -- SCBA OPENINGS AND COMPARTMENTS</b>				<b>BME</b>
24-05-5700		SCBA Stge, Psngr, Fwd Wheelwell, 8" Round	1	BME
24-05-2450		-- SCBA Door, Cast Products, Lever Latch	1	BME

PART NO	S	DESCRIPTION	QTY	ID
24-05-2500		-- SCBA Tube, Plastic, w/ Mat	1	BME
24-19-0415		-- Lever Latch, Textured Chrome Raised Button, Non-locking, Each	1	BME
24-05-7000		-- SCBA Cylinder Tether, 1" Nylon	1	BME
24-05-6300		SCBA Stge, Psngr, Rear Wheelwell, 8" Round	1	BME
24-05-2450		-- SCBA Door, Cast Products, Lever Latch	1	BME
24-05-2500		-- SCBA Tube, Plastic, w/ Mat	1	BME
24-19-0415		-- Lever Latch, Textured Chrome Raised Button, Non-locking, Each	1	BME
24-05-7000		-- SCBA Cylinder Tether, 1" Nylon	1	BME
<b>RUB RAILS</b>				<b>BME</b>
24-07-6330		Rub Rails, Alum Chan, 2" x 1.5", Ribbed	1	BME
81-15-1522		-- Reflective Color, White	1	BME
<b>FRONT AND REAR BODY SURFACE -- SCUFF PLATES</b>				<b>BME</b>
24-08-1000		*** Front of Body ***	1	BME
24-08-1100		Protective Surface, Alum T/P, Entire Front	1	BME
24-08-2100		Protective Front Corner Trim, S/S	1	BME
24-08-2999			1	BME
24-08-3000		*** Rear of Body ***	1	BME
24-08-3400		Rear Body Panels, Painted	1	BME
24-08-4200		Protective Rear Corner Trim, S/S	1	BME
24-08-4999			1	BME
24-08-5000		*** Top of Body ***	1	BME
24-08-5100		Protective Surfaces, Alum T/P, Top of Side Cmpts	1	BME
24-08-7999			1	BME
24-08-8000		*** Anodized Aluminum Drip Rails ***	1	BME
24-08-8100		Drip Rails	1	BME
<b>HINGED DOORS -- ALUMINUM PAINTED</b>				<b>BME</b>
24-12-1100		Doors, Hinged, Alum Painted, Single, Base Specs	1	BME
24-18-2310		-- D-ring, Polished	1	BME
24-18-2420		-- Door Locks, D-Ring, Hinged, 1250 Key Type, Each	1	BME
81-20-2505		-- Stripe, Cmpt Door, Reflective, Each, Color Options	1	BME
81-15-1521		-- Reflective Color, Red/Wht DOT	1	BME
24-12-1200		Doors, Hinged, Alum Painted, Double-Door	5	BME
24-18-2310		-- D-ring, Polished	5	BME
24-18-2420		-- Door Locks, D-Ring, Hinged, 1250 Key Type, Each	5	BME
81-20-2505		-- Stripe, Cmpt Door, Reflective, Each, Color Options	10	BME
81-15-1521		-- Reflective Color, Red/Wht DOT	10	BME
<b>===== REAR STEPS =====</b>				<b>BME</b>
24-20-3000		*** Rear Steps - Extruded Aluminum DIAMOND BACK ***	1	BME

PART NO	S	DESCRIPTION	QTY	ID
24-20-3165		Rear Step, 3 Piece w/step, Extruded Alum, Diamond Back, M34	1	BME
<b>AUXILIARY STEPS</b>				<b>BME</b>
24-21-3190		Steps, Fixed CPI, Drivers, Rear	3	BME
24-21-3230		Steps, Fixed CPI, Psngr, Rear	3	BME
<b>HANDRAILS AND GRAB HANDLES</b>				<b>BME</b>
24-26-5299		***Knurled Grab Handles***	1	BME
24-26-5301		Handrails, Knurled, Vertical, 18"	1	BME
24-26-5305		Handrails, Knurled, Vertical, 42"	2	BME
24-26-5320		Handrails, Knurled, Horizontal, 12"	2	BME
24-26-5321		Handrails, Knurled, Horizontal, 18"	2	BME
24-26-5328		Handrails, Knurled, Horizontal, 60"	1	BME
<b>HOSE BED CONSTRUCTION</b>				<b>BME</b>
24-30-2210		Hose Bed, Aluminum, Spec, Wildland, (Model 34 2021)	1	BME
<b>HOSEBED DIVIDERS</b>				<b>BME</b>
24-32-1005		--NO Hosebed Divider	1	BME
24-32-3525		Hose Storage, I-Zone Brokts, Rear (2) , Model 34	1	BME
<b>HOSEBED GRATING</b>				<b>BME</b>
24-32-4115		Hosebed, Grating, Alum, Wildland (Model 34 2021)	1	BME
<b>HOSEBED COVERS -- WILDLAND TRUCKS</b>				<b>BME</b>
24-33-1115		Hosebed Covers, Alum T/P, Dbl Door, Flap, Model 34	1	BME
24-32-7305		-- Hosebed Rear Flap and Straps, Model 34	1	BME
24-33-5120		-- Hosebed Flaps, Color, Red	1	BME
41-35-1835		-- Hosebed Lights, Tecniq E10, LED	4	BME
41-46-2005		-- Door Open Sensor, Compt Door	1	BME
<b>===== WATER TANK SPECIFICATIONS</b>				<b>BME</b>
28-01-1501		Water Tank Capacity, 500 Gallons, Poly (Model 34)	1	BME
28-02-1100		-- Water Tank Shape, Rectangular	1	BME
28-04-1200		-- Fill Tower, Water Tank, 8" x 8" x 8", Type 3	1	BME
28-06-1100		-- Fill Tower, Overflow, Water Tank, 3" PVC Pipe, <500G	1	BME
28-07-1305		-- Sump, Water Tank, Model 34	1	BME
28-10-1100		-- Water Tank Drain, 3"	1	BME
29-05-1205		-- Foam Tank Capacity, 20 Gallons, Poly, Model 34, Seperate	1	BME

PART NO	S	DESCRIPTION	QTY	ID
29-40-1100		-- Foam Tank, Fill and Vent, Class A	1	BME
29-50-1050		-- Foam Tank Drain and Valve, 3/4"	1	BME
<b>DIRECT TANK FILL CONNECTIONS</b>				<b>BME</b>
28-31-1000		*** Direct Tank Quarter-Turn Fill Valve - Rear ***	1	BME
28-31-1100		Direct Tank Fill Valve, Drivers, Rear, 2.5", w/Strainer and Plug	1	BME
10-15-1120		-- Valves, Akron, Brass, 8825 Series (Uses R1, TS or TSC Handles Only)	1	BME
10-20-0060		-- Valve, Direct, Local Control, Akron locking TSC	1	BME
11-07-1100		-- Plug, 2.5", Chrome Brass, Rocker Lug	1	BME
12-21-3700		-- Elbow, 2.5"F x 2.5"M, Chrome Brass, Direct Tank Fill	1	BME
<b>BACK PACK FILL PROVISIONS</b>				<b>BME</b>
28-32-3155		Back Pack Fill, GHT x 1/2"NPT, w/vlv, Pump Panel, M34	1	BME
<b>===== 12 VOLT ELECTRICAL =====</b>				<b>BME</b>
40-05-1000		*** 12 Volt Base Electrical Wiring ***	1	BME
40-05-1150		Electrical, 12V, Base Wiring Specs, Wildland	1	BME
40-05-4600		-- Electrical Harness, Wildland	1	BME
<b>CONSOLES AND SWITCH PANELS</b>				<b>BME</b>
40-10-0005		NO--Rear Console	1	BME
40-10-1210	XS	Electrical Console, Cab, BME, Freightliner M2+, AP-00-020627	1	BME
40-10-9900	XS	-- Console Finish	1	BME
80-21-2322		-- Multi-Spec, Color, Hamlet Black	1	BME
42-21-1110	XS	-- 12V Power Outlet, 20 Amp, Console	2	BME
42-21-3310	XS	-- 12 Volt Pwr Source, Switched Battery	2	BME
42-21-1550	XS	-- USB Fast Charge Port, Blue Sea, Dual, Socket Mount	2	BME
42-21-3310	XS	-- 12 Volt Pwr Source, Switched Battery	2	BME
<b>BATTERY EQUIPMENT INSTALLATION</b>				<b>BME</b>
40-15-1000		*** Battery And Ignition Switches ***	1	BME
40-15-1150		Battery Switch, Master Disconnect, Chassis Supplied	1	BME
40-15-2999			1	BME
40-15-3000		*** Battery Charger Systems ***	1	BME
40-15-3310		Battery Charger, Kussmaul, Autocharge 1000 PLC, Deluxe Pkg, 51-04-1304, 20A	1	BME
40-15-6201		-- Kussmaul Auto Eject Cover, Yellow	1	BME
<b>VEHICLE IDENTIFICATION LIGHTS</b>				<b>BME</b>

PART NO	S	DESCRIPTION	QTY	ID
40-25-1355		Clearance Lgts, LED, DOT, Wildland, Model 34	1	BME
		<b>LICENSE PLATE MOUNTING</b>		<b>BME</b>
40-30-1310		License Plate Mounting, Tecniq LED, L110, Rear	1	BME
		<b>STOP - TAIL - TURN - BACK-UP INDIVIDUAL LIGHTS</b>		<b>BME</b>
40-66-0010		Stop, Tail, Turn Lights, Whelen M Series, Quad, Package	1	BME
40-32-1000		-- *** Tail and Stop Lights ***	1	BME
40-32-5155		-- Stop/Tail Lgts, Whelen #M62BTTC, LED, 4" x 6",(2)	1	BME
40-32-9999		--	1	BME
40-33-1000		-- *** Turn Signals ***	1	BME
40-33-5165		-- Turn Signals, Whelen M62TC, LED, LED, (2)	1	BME
40-34-9999		--	1	BME
40-35-1000		-- *** Back Up Lights ***	1	BME
40-35-5150		-- Back up Lights, Whelen M62BU, LED, 4" x 6", (2)	1	BME
40-55-1999		--	1	BME
40-55-2000		-- *** Tail Light Mountings and Bezels -- 4 Lights ***	1	BME
40-55-2300		-- Tail Light Bezels, Whelen #M6FCV4, (4) lts, 4" x 6" (2)	1	BME
45-75-9999		--	1	BME
45-80-1000		-- *** Lower Rear Warning Lights ***	1	BME
45-80-1815		-- Warning Lights, Whelen, M6RC, Lower Rear, (2), (No Bezel)	1	BME
		<b>MAP LIGHTS</b>		<b>BME</b>
41-15-1605		Map Light, Havis Shields #C-MAP-T-LED, 12" LED (Model 34)	1	BME
		<b>UNDERBODY AND GROUND LIGHTS</b>		<b>BME</b>
41-25-1000		*** Bumper Ground Lights ***	1	BME
41-25-1305		Ground Lights, Front Bumper, Tecniq E10, LED	2	BME
41-25-5360		-- Ground Lights, Activation, Park Brake/Park Signal	2	BME
41-25-1999			1	BME
41-25-2000		*** Cab Ground Lights ***	1	BME
41-25-2510		Ground Lights, Cab, 4 Door, Tecniq E10, LED	4	BME
41-25-5360		-- Ground Lights, Activation, Park Brake/Park Signal	4	BME
41-25-2999			1	BME
41-25-3000		*** Body Ground Lights ***	1	BME
41-25-3210		Ground Lights, Pump Panel, Tecniq E10, LED	2	BME
41-25-5360		-- Ground Lights, Activation, Park Brake/Park Signal	2	BME
41-25-3499			1	BME
41-25-5255		Ground Lights, Under Rear Step, Tecniq E10, LED	2	BME
41-25-5360		-- Ground Lights, Activation, Park Brake/Park Signal	2	BME
		<b>SCENE LIGHTS</b>		<b>BME</b>

PART NO	S	DESCRIPTION	QTY	ID
41-36-5285		Scene Light, Whelen, Pioneer Micro, MPBB, Middle Rear Steps M34	2	BME
41-36-5290		Scene Light, Whelen, Pioneer Micro, MPBB, Frnt Bumper	1	BME
41-40-6425		-- Scene Light Switching, Cab Console, Individual (Front)	1	BME
41-36-5300		Scene Light, Whelen, PCPSM1C, LED	4	BME
41-40-6401		-- Scene Light Switching, Cab Console, Individual (Left Right Rear)	1	BME
<b>HINGED DOOR COMPARTMENT LIGHTS</b>				<b>BME</b>
41-46-2000		*** Door Open Light and Alarm ***	1	BME
41-46-2125		Door Open Light and Buzzer, Zones, Model 34	1	BME
<b>RADIOS AND ANTENNAS</b>				<b>BME</b>
42-10-1005		NO--Radio Prewire	1	BME
42-10-1006		NO--Radio Installation.	1	BME
42-10-2015		Radio Antenna, Installation	4	BME
<b>BACK UP ALARMS</b>				<b>BME</b>
43-10-1110		Back Up Alarm, Self Adjusting	1	BME
<b>HEADLIGHT FLASHERS OR WIG-WAG</b>				<b>BME</b>
43-15-1760		Headlight, Flasher, Wig-Wag	1	BME
43-15-2030		-- Wig Wag, Activation, Siren Controller, Slide Switch Pos #3	1	BME
<b>ELECTRONIC SIRENS AND SPEAKERS</b>				<b>BME</b>
44-05-1000		*** Whelen Siren/PA Systems ***	1	BME
44-05-1288		Siren, Electronic, Whelen, CenCom Core C399, T/A	1	BME
44-05-1302		-- Whelen, Core, Control Head, CCTL6	1	BME
44-05-1322		-- Whelen, Core, WeCanX, Traffic Advisor Module, CTA	1	BME
44-09-1000		*** Siren Speakers ***	1	BME
44-09-1500		Speaker, Whelen, #SA315P, 100 Watt, nylon housing	1	BME
<b>ZONE A -- UPPER CAB LIGHTBARS</b>				<b>BME</b>
45-05-2026	XS	Lightbar, Whelen, Cenator, Duo, WeCanX, 60"	1	BME
<b>LOWER ZONE A -- FRONT LOWER</b>				<b>BME</b>
45-40-1610		Warning Lights, Whelen, M6D RED/WHT, Lwr Front, (2)	1	BME
41-40-7530		-- Bezels, Whelen, M6, Chrome Plastic	2	BME

PART NO	S	DESCRIPTION	QTY	ID
45-40-1705		Warning Lights, Whelen, Lower Front, ION-T, TLIR, (2)	1	BME
		<b>ZONE B AND D -- LOWER CAB INTERSECTION LIGHTS</b>		<b>BME</b>
45-45-1515		Warning Lights, Whelen, M6RC, Intersection, (2), LED	1	BME
41-40-7530		-- Bezels, Whelen, M6, Chrome Plastic	2	BME
		<b>ZONE B AND D -- LOWER MID-BODY SIDE WARNING LIGHTS</b>		<b>BME</b>
45-55-1515		Warning Lights, Whelen, M6RC, Lwr Mid Body, (2), LED	1	BME
41-40-7530		-- Bezels, Whelen, M6, Chrome Plastic	2	BME
		<b>ZONE B AND D -- UPPER REAR CORNER BODY WARNING LIGHTS</b>		<b>BME</b>
45-70-1515		Warning Lights, Whelen, M6RC, Upper Side Rear, (2), LED	1	BME
41-40-7530		-- Bezels, Whelen, M6, Chrome Plastic	2	BME
		<b>ZONE C -- UPPER REAR WARNING LIGHTS</b>		<b>BME</b>
45-75-1515		Warning Lights, Whelen, M6RC, Upper Rear, (2), LED	1	BME
41-40-7530		-- Bezels, Whelen, M6, Chrome Plastic	2	BME
		<b>TRAFFIC ARROWS</b>		<b>BME</b>
46-05-1860		Traffic Advisor, Whelen, TAZ86, LED, Eight Lamp	1	BME
		<b>===== PAINTING =====</b>		<b>BME</b>
80-00-0001	XS	Paint Codes - Candy Apple Red - 97902EY	1	BME
		<b>EXTERIOR PAINTING --- BODY</b>		<b>BME</b>
80-10-0002		*** Wildland -- Exterior Body Painting ***	1	BME
80-10-1000		Paint, Wildland, 60-84" CA Body, Single Axle, 1 Color	1	BME
		<b>INTERIOR PAINTING --- COMPARTMENTS</b>		<b>BME</b>
80-21-2305		Cmpt Pntg, Multispec, (6) Compts.	1	BME
80-21-2322		-- Multi-Spec, Color, Hamlet Black	1	BME
		<b>MISCELLANEOUS PAINTING AND BODY FINISHING OPTIONS</b>		<b>BME</b>
80-60-0000		*** Touch Up Paint ***	1	BME
80-60-1000		Body Paint, Touch Up, Pint One Color	1	BME

PART NO	S	DESCRIPTION	QTY	ID
80-61-9999			1	BME
80-65-0000		*** Miscellaneous Painting ***	1	BME
80-65-1200		Painting, Valves, To Match Truck	1	BME
<b>===== BLACKOUT PACKAGE =====</b>				BME
<b>REFLECTIVE STRIPING</b>				BME
81-20-4200	XS	Stripe, Reflective, SCOTCHLITE Chevron, Tail Panels Only	1	BME
81-20-6005		Striping Package, Single 4" Reflective Stripe (Medium)	1	BME
<b>WHEEL CHOCKS</b>				BME
90-09-1710		Wheel Chocks, Worden, Alum, w/Handle, Large, HWC-7WH (2)	2	BME
<b>FIRE EXTINGUISHERS</b>				BME
90-10-1110		Extinguisher, Dry Chem, 5#, 2A:10B:C, w/mntg	1	BME
<b>----- MISCELLANEOUS EQUIPMENT -----</b>				BME
90-40-4100		Jack, Northern Hyd, 1442, 12T, Hyd bottle	1	BME
90-40-4500		Lug Wrench and Breaker Bar	1	BME
<b>NFPA AND DOT SAFETY AND HIGHWAY EQUIPMENT</b>				BME
90-42-1200		Reflector Set, Triangular D.O.T.	1	BME

# H-GAC

Houston-Galveston Area Council

P.O. Box 22777 · 3555 Timmons · Houston, Texas 77227-2777

Cooperative Agreement - Contract - Siddons Martin Emergency Group LLC - Public Services - ID: 11564 - -  
FS12-23

## MASTER GENERAL PROVISIONS

This Master Agreement is made and entered into, by and between the Houston-Galveston Area Council hereinafter referred to as H-GAC having its principal place of business at 3555 Timmons Lane, Suite 120, Houston, Texas 77027 and Siddons Martin Emergency Group LLC, hereinafter referred to as the Contractor, having its principal place of business at 1362 E Richey Road, Houston, TX 77073.

WITNESSETH:

WHEREAS, H-GAC hereby engages the Contractor to perform certain services in accordance with the specifications of the Master Agreement; and

WHEREAS, the Contractor has agreed to perform such services in accordance with the specifications of the Master Agreement;

NOW, THEREFORE, H-GAC and the Contractor do hereby agree as follows:

### ARTICLE 1: LEGAL AUTHORITY

The Contractor warrants and assures H-GAC that it possesses adequate legal authority to enter into this Master Agreement. The Contractor's governing body, where applicable, has authorized the signatory official(s) to enter into this Master Agreement and bind the Contractor to the terms of this Master Agreement and any subsequent amendments hereto.

### ARTICLE 2: APPLICABLE LAWS

The Contractor agrees to conduct all activities under this Master Agreement in accordance with all federal laws, executive orders, policies, procedures, applicable rules, regulations, directives, standards, ordinances, and laws, in effect or promulgated during the term of this Master Agreement, including without limitation, workers' compensation laws, minimum and maximum salary and wage statutes and regulations, and licensing laws and regulations. When required, the Contractor shall furnish H-GAC with satisfactory proof of its compliance therewith.

### ARTICLE 3: PUBLIC INFORMATION

Except as stated below, all materials submitted to H-GAC, including any attachments, appendices, or other information submitted as a part of a submission or Master Agreement, are considered public information, and become the property of H-GAC upon submission and may be reprinted, published, or distributed in any manner by H-GAC according to open records laws, requirements of the US Department of Labor and the State of Texas, and H-GAC policies and procedures. In the event the Contractor wishes to claim portions of the response are not subject to the Texas Public Information Act, it shall so; however, the determination of the Texas Attorney General as to whether such information must be disclosed upon a public request shall be binding on the Contractor. H-GAC will request such a determination only if Contractor bears all costs for preparation of the submission. H-GAC is not responsible for the return of creative examples of work submitted. H-GAC will not be held accountable if material from submissions is obtained without the written consent of the contractor by parties other than H-GAC, at any time during the evaluation process.

### ARTICLE 4: INDEPENDENT CONTRACTOR

The execution of this Master Agreement and the rendering of services prescribed by this Master Agreement do not change the independent status of H-GAC or the Contractor. No provision of this Master Agreement or act of H-GAC in performance of the Master Agreement shall be construed as making the Contractor the agent, servant, or

employee of H-GAC, the State of Texas, or the United States Government. Employees of the Contractor are subject to the exclusive control and supervision of the Contractor. The Contractor is solely responsible for employee related disputes and discrepancies, including employee payrolls and any claims arising therefrom.

**ARTICLE 5: ANTI-COMPETITIVE BEHAVIOR**

Contractor will not collude, in any manner, or engage in any practice which may restrict or eliminate competition or otherwise restrain trade.

**ARTICLE 6: SUSPENSION AND DEBARMENT**

Debarment and Suspension (Executive Orders 12549 and 12689) – A contract award (2 CFR 180.220) must not be made to parties listed on the government-wide exclusions in the System for Award Management (SAM), in accordance with the OMB guidelines at 2 CFR 180 that implement Executive Orders 12549 (3 CFR Part 1966 Comp. p. 189) and 12689 (3 CFR Part 1989 Comp. p. 235), “Debarment and Suspension.” SAM Exclusions contains the names of parties debarred, suspended, or otherwise excluded by agencies, as well as parties declared ineligible under statutory or regulatory authority other than Executive Order 12549.

Pursuant to the Federal Rule above, Respondent certifies that neither it nor its principals are presently debarred, suspended, proposed for debarment, declared ineligible, or voluntarily excluded from participation by any federal department or agency or by the State of Texas and at all times during the term of the Contract neither it nor its principals will be debarred, suspended, proposed for debarment, declared ineligible, or voluntarily excluded from participation by any federal department or agency or by the State of Texas Respondent shall immediately provide the written notice to H-GAC if at any time the Respondent learns that this certification was erroneous when submitted or has become erroneous by reason of changed circumstances. H-GAC may rely upon a certification of the Respondent that the Respondent is not debarred, suspended, ineligible, or voluntarily excluded from the covered contract, unless the H-GAC knows the certification is erroneous.

**ARTICLE 7: GOAL FOR CONTRACTING WITH SMALL AND MINORITY BUSINESSES, WOMEN'S BUSINESS ENTERPRISES, AND LABOR SURPLUS AREA FIRMS (if subcontracts are to be let)**

H-GAC's goal is to assure that small and minority businesses, women's business enterprises, and labor surplus area firms are used when possible in providing services under a contract. In accordance with federal procurements requirements of 2 CFR §200.321, if subcontracts are to be let, the prime contractor must take the affirmative steps listed below:

1. Placing qualified small and minority businesses and women's business enterprises on solicitation lists;
2. Assuring that small and minority businesses and women's business enterprises are solicited whenever they are potential sources;
3. Dividing total requirements, when economically feasible, into smaller task or quantities to permit maximum participation by small and minority businesses, and women's business enterprises;
4. Establishing delivery schedules, where the requirement permits, which encourage participation by small and minority businesses, and women's business enterprises;
5. Using the services and assistance as appropriate, of such organizations as the Small Business Administration and the Minority Business Development Agency of the Department of Commerce.
- 6.

Nothing in this provision will be construed to require the utilization of any firm that is either unqualified or unavailable. The Small Business Administration (SBA) is the primary reference and database for information on requirements related to Federal Subcontracting <https://www.sba.gov/federal-contracting-contracting-guide/prime-subcontracting>

NOTE: The term DBE as used in this solicitation is understood to encompass all programs/business enterprises such as: Small Disadvantaged Business (SDB), Historically Underutilized Business (HUB), Minority Owned Business Enterprise (MBE), Women Owned Business Enterprise (WBE) and Disabled Veteran Business Enterprise (DVBE) or other designation as issued by a certifying agency.

**Contractor agrees to work with and assist HGACBuy customer in meeting any DBE targets and goals, as may be required by any rules, processes, or programs they might have in place. Assistance may include compliance with reporting requirements, provision of documentation, consideration of Certified/Listed**

**subcontractors, provision of documented evidence that an active participatory role for a DBE entity was considered in a procurement transaction, etc.**

#### **ARTICLE 8: SCOPE OF SERVICES**

The services to be performed by the Contractor are outlined in an Attachment to this Master Agreement.

#### **ARTICLE 9: PERFORMANCE PERIOD**

This Master Agreement shall be performed during the period which begins Dec 01 2023 and ends Nov 30 2027. All services under this Master Agreement must be rendered within this performance period, unless directly specified under a written change or extension provisioned under Article 21, which shall be fully executed by both parties to this Master Agreement.

#### **ARTICLE 10: PAYMENT OR FUNDING**

Payment provisions under this Master Agreement are outlined in the Special Provisions. H-GAC will not pay for any expenses incurred prior to the execution date of a contract, or any expenses incurred after the termination date of the contract.

#### **ARTICLE 11: PAYMENT FOR WORK**

The H-GAC Customer is responsible for making payment to the Contractor upon delivery and acceptance of the goods or completion of the services and submission of the subsequent invoice.

#### **ARTICLE 12: PAYMENT TERMS/PRE-PAYMENT/QUANTITY DISCOUNTS**

If discounts for accelerated payment, pre-payment, progress payment, or quantity discounts are offered, they must be clearly indicated in the Contractor's submission prior to contract award. The applicability or acceptance of these terms is at the discretion of the Customer.

#### **ARTICLE 13: REPORTING REQUIREMENTS**

If the Contractor fails to submit to H-GAC in a timely and satisfactory manner any report required by this Master Agreement, or otherwise fails to satisfactorily render performances hereunder, H-GAC may terminate this Master Agreement with notice as identified in Article 29 of these General Provisions. H-GAC has final determination of the adequacy of performance and reporting by Contractor. Termination of this Master Agreement for failure to perform may affect Contractor's ability to participate in future opportunities with H-GAC. The Contractor's failure to timely submit any report may also be considered cause for termination of this Master Agreement. Any additional reporting requirements shall be set forth in the Special Provisions of this Master Agreement.

#### **ARTICLE 14: INSURANCE**

Contractor shall maintain insurance coverage for work performed or services rendered under this Master Agreement as outlined and defined in the attached Special Provisions.

#### **ARTICLE 15: SUBCONTRACTS AND ASSIGNMENTS**

Except as may be set forth in the Special Provisions, the Contractor agrees not to assign, transfer, convey, sublet, or otherwise dispose of this Master Agreement or any right, title, obligation, or interest it may have therein to any third party without prior written approval of H-GAC. The Contractor acknowledges that H-GAC is not liable to any subcontractor or assignee of the Contractor. The Contractor shall ensure that the performance rendered under all subcontracts shall result in compliance with all the terms and provisions of this Master Agreement as if the performance rendered was rendered by the Contractor. Contractor shall give all required notices, and comply with all laws and regulations applicable to furnishing and performance of the work. Except where otherwise expressly required by applicable law or regulation, H-GAC shall not be responsible for monitoring Contractor's compliance, or that of Contractor's subcontractors, with any laws or regulations.

#### **ARTICLE 16: AUDIT**

Notwithstanding any other audit requirement, H-GAC reserves the right to conduct or cause to be conducted an independent audit of any transaction under this Master Agreement, such audit may be performed by the H-GAC

local government audit staff, a certified public accountant firm, or other auditors designated by H-GAC and will be conducted in accordance with applicable professional standards and practices. The Contractor understands and agrees that the Contractor shall be liable to the H-GAC for any findings that result in monetary obligations to H-GAC.

**ARTICLE 17: TAX EXEMPT STATUS**

H-GAC and Customer members are either units of government or qualified non-profit agencies, and are generally exempt from Federal and State sales, excise or use taxes. Respondent must not include taxes in its Response. It is the responsibility of Contractor to determine the applicability of any taxes to an order and act accordingly. Exemption certificates will be provided upon request.

**ARTICLE 18: EXAMINATION OF RECORDS**

The Contractor shall maintain during the course of the work complete and accurate records of all of the Contractor's costs and documentation of items which are chargeable to H-GAC under this Master Agreement. H-GAC, through its staff or designated public accounting firm, the State of Texas, and United States Government, shall have the right at any reasonable time to inspect, copy and audit those records on or off the premises by authorized representatives of its own or any public accounting firm selected by H-GAC. The right of access to records is not limited to the required retention period, but shall last as long as the records are retained. Failure to provide access to records may be cause for termination of the Master Agreement. The records to be thus maintained and retained by the Contractor shall include (without limitation): (1) personnel and payroll records, including social security numbers and labor classifications, accounting for total time distribution of the Contractor's employees working full or part time on the work, as well as cancelled payroll checks, signed receipts for payroll payments in cash, or other evidence of disbursement of payroll payments; (2) invoices for purchases, receiving and issuing documents, and all other unit inventory records for the Contractor's stocks or capital items; and (3) paid invoices and cancelled checks for materials purchased and for subcontractors' and any other third parties' charges.

Contractor agrees that H-GAC will have the right, with reasonable notice, to inspect its records pertaining to purchase orders processed and the accuracy of the fees payable to H-GAC. The Contractor further agrees that the examination of records outlined in this article shall be included in all subcontractor or third-party Master Agreements.

**ARTICLE 19: RETENTION OF RECORDS**

The Contractor and its subcontractors shall maintain all records pertinent to this Master Agreement, and all other financial, statistical, property, participant records, and supporting documentation for a period of no less than seven (7) years from the later of the date of acceptance of the final payment or until all audit findings have been resolved. If any litigation, claim, negotiation, audit or other action involving the records has been started before the expiration of the retention period, the records shall be retained until completion of the action and resolution of all issues which arise from it, or until the end of the seven (7) years, whichever is later, and until any outstanding litigation, audit, or claim has been fully resolved.

**ARTICLE 20: DISTRIBUTORS, VENDORS, RESELLERS**

Contractor agrees and acknowledges that any such designations of distributors, vendors, resellers or the like are for the convenience of the Contractor only and the awarded Contractor will remain responsible and liable for all obligations under the Contract and the performance of any designated distributor, vendor, reseller, etc. Contractor is also responsible for receiving and processing any Customer purchase order in accordance with the Contract and forwarding of the Purchase Order to the designated distributor, vendor, reseller, etc. to complete the sale or service. H-GAC reserves the right to reject any entity acting on the Contractor's behalf or refuse to add entities after a contract is awarded.

**ARTICLE 21: CHANGE ORDERS AND AMENDMENTS**

- A. Any alterations, additions, or deletions to the terms of this Master Agreement, which are required by changes in federal or state law or by regulations, are automatically incorporated without written amendment hereto, and shall become effective on the date designated by such law or by regulation.
- B. To ensure the legal and effective performance of this Master Agreement, both parties agree that any amendment that affects the performance under this Master Agreement must be mutually agreed upon and that all such amendments must be in writing. After a period of no less than 30 days subsequent to written notice, unless sooner implementation is required by law, such amendments shall have the effect of qualifying the terms of this Master Agreement and shall be binding upon the parties as if written herein.
- C. Customers have the right to issue a change order to any purchase orders issued to the Contractor for the purposes of clarification or inclusion of additional specifications, qualifications, conditions, etc. The change order must be in writing and agreed upon by Contractor and the Customer agency prior to issuance of any Change Order. A copy of the Change Order must be provided by the Contractor to, and acknowledged by, H-GAC.

#### **ARTICLE 22: CONTRACT ITEM CHANGES**

- A. If a manufacturer discontinues a contracted item, that item will automatically be considered deleted from the contract with no penalty to Contractor. However, H-GAC may at its sole discretion elect to make a contract award to the next lowest Respondent for the item, or take any other action deemed by H-GAC, at its sole discretion, to be in the best interests of its Customers.
- B. If a manufacturer makes any kind of change in a contracted item which affects the contract price, Contractor must advise H-GAC of the details. H-GAC may allow or reject the change at its sole discretion. If the change is rejected, H-GAC will remove the item from its program and there will be no penalty to Contractor. However, H-GAC may at its sole discretion elect to make a contract award to the next lowest Respondent for the item, or take any other action deemed by H-GAC, at its sole discretion, to be in the best interests of its Customers.
- C. If a manufacturer makes any change in a contracted item which does not affect the contract price, Contractor shall advise H-GAC of the details. If the 'new' item is equal to or better than the originally contracted item, the 'new' item shall be approved as a replacement. If the change is rejected H-GAC will remove the item from its program and there will be no penalty to Contractor. However, H-GAC may at its sole discretion elect to make a contract award to the next lowest Respondent for the item or may take any other action deemed by H-GAC at its sole discretion, to be in the best interests of its Customers.
- D. In the case of specifically identified catalogs or price sheets which have been contracted as base bid items or as published options, routine published changes to products and pricing will be automatically incorporated into the contract. However, Contractor must still provide written notice and an explanation of the changes to products and pricing. H-GAC will respond with written approval.

#### **ARTICLE 23: CONTRACT PRICE ADJUSTMENTS**

##### **Price Decreases**

If Contractor's Direct Cost decreases at any time during the full term of this award, Contractor must immediately pass the decrease on to H-GAC and lower its prices by the amount of the decrease in Direct Cost. (Direct Cost means Contractor's cost from the manufacturer of any item or if Contractor is the manufacturer, the cost of raw materials required to manufacture the item, plus costs of transportation from manufacturer to Contractor and Contractor to H-GAC. Contractor must notify H-GAC of price decreases in the same way as for price increases set out below. The price decrease shall become effective upon H-GAC's receipt of Contractor's notice. If Contractor routinely offers discounted contract pricing, H-GAC may request Contractor accept amended contract pricing equivalent to the routinely discounted pricing.

### **Price Increase**

Contractors may request a price increase for items priced as Base Bid items and Published Options. The amount of any increase will not exceed actual documented increase in Contractor's Direct Cost and will not exceed 10% of the previous bid price. Considerations on the percentage limit will be given if the price increase is the result of increased tariff charges or other governmental actions, or other economic factors. Manufacturer price/contract changes involving the sale of motor vehicles will be considered and may be allowed during the entire contract period subject to submission and verification of the proper documentation required for a contract change as referenced in this section.

### **Price Changes**

Any permanent increase or decrease in offered pricing for a base contract item or published option is considered a price change. Temporary increases in pricing by whatever name (e.g., 'surcharge', 'adjustment', 'equalization charge', 'compliance charge', 'recovery charge', etc.), are also considered to be price changes. For published catalogs and price sheets as part of an H-GAC contract, requests to amend the contract to reflect any new published catalog or price sheet must be submitted whenever the manufacturer publishes a new document. The request must include the new catalog or price sheet. All Products shall, at time of sale, be equipped as required under any then current applicable local, state, and federal government requirements. If, during any contract, changes are made to any government requirements which cause a manufacturer's costs of production to increase, Contractor may increase pricing to the extent of Contractor's actual cost increase. The increase must be substantiated with support documentation acceptable to H-GAC prior to taking effect. Modifications to a Product required to comply with such requirements which become effective after the date of any sale are the responsibility of the Customer.

### **Requesting Price Increase/Required Documentation**

Contractor must submit a written overview of changes requested and reasons for the request, stating the amount of the increase, along with an itemized list of any increased prices, showing the Contractor's current price, revised price, the actual dollar difference and the percentage of the price increase by line item. Price change requests must be supported with substantive documentation (e.g., notices from suppliers and manufacturers of pricing changes in products, components, transportation, raw materials or commodities, and/or product availability, copies of invoices from suppliers, etc.) clearly showing that Contractor's actual costs have increased per the applicable line-item bid. The Producer Price Index (PPI) may be used as partial justification, subject to approval by H-GAC, but no price increase based solely on an increase in the PPI will be allowed. This documentation should be submitted in Excel format to facilitate analysis and updating of the website. The letter and documentation must be sent to Lead Program Coordinator, [james.glover@h-gac.com](mailto:james.glover@h-gac.com).

### **Review/Approval of Requests**

If H-GAC approves the price increase, Contractor will be notified in writing; no price increase will be effective until Contractor receives this notice. If H-GAC does not approve Contractor's price increase, Contractor may terminate its performance upon sixty (60) days advance written notice to H-GAC, however Contractor must fulfill any outstanding Purchase Orders. Termination of performance is Contractor's only remedy if H-GAC does not approve the price increase. H-GAC reserves the right to accept or reject any price change request.

### **ARTICLE 24: DELIVERIES AND SHIPPING TERMS**

The Contractor agrees to make deliveries only upon receipt of authorized Customer Purchase Order acknowledged by H-GAC. Delivery made without such Purchase Order will be at Contractor's risk and will leave H-GAC the option of canceling any contract awarded to the Contractor. The Contractor must secure and deliver any item within five (5) working days, or as agreed to on any corresponding customer Purchase Order.

Shipping must be Freight On Board Destination to the delivery location designated on the Customer purchase order. The Contractor will retain title and control of all goods until delivery is completed and the Customer has accepted the delivery. All risk of transportation and all related charges are the responsibility of the Contractor. The Customer will notify the Contractor and H-GAC promptly of any damaged goods and will assist the Contractor in arranging for inspection. The Contractor must file all claims for visible or concealed damage. Unless otherwise stated in the Master Agreement, deliveries must consist only of new and unused merchandise.

**ARTICLE 25: RESTOCKING (EXCHANGES AND RETURNS)**

There will be no restocking charge to the Customer for return or exchange of any item purchased under the terms of any award. If the Customer wishes to return items purchased under an awarded contract, the Contractor agrees to exchange, these items for other items, with no additional charge incurred. Items must be returned to Contractor within thirty (30) days from date of delivery. If there is a difference in price in the items exchanged, the Contractor must notify H-GAC and invoice Customer for increase price or provide the Customer with a credit or refund for any decrease in price per Customer's preference. On items returned, a credit or cash refund will be issued by the Contractor to Customer. This return and exchange option will extend for thirty (30) days following the expiration of the term of the Contract. All items returned by the Customer must be unused and in the same merchantable condition as when received. Items that are special ordered may be returned only upon approval of the Contractor.

**ARTICLE 26: MANUALS**

Each product delivered under contract to any Customer must be delivered with at least one (1) copy of a safety and operating manual and any other technical or maintenance manual. The cost of the manual(s) must be included in the price for the Product offered.

**ARTICLE 27: OUT OF STOCK, PRODUCT RECALLS, AND DISCONTINUED PRODUCTS**

H-GAC does NOT purchase the products sold pursuant to a Solicitation or Master Agreement. Contractor is responsible for ensuring that notices and mailings, such as Out of Stock or Discontinued Notices, Safety Alerts, Safety Recall Notices, and customer surveys, are sent directly to the Customer with a copy sent to H-GAC. Customer will have the option of accepting any equivalent product or canceling the item from Customer's Purchase Order. Contractor is not authorized to make substitutions without prior approval.

**ARTICLE 28: WARRANTIES, SALES, AND SERVICE**

Warranties must be the manufacturer's standard and inclusive of any other warranty requirements stated in the Master Agreement; any warranties offered by a dealer will be in addition to the manufacturer's standard warranty and will not be a substitute for such. Pricing for any product must be inclusive of the standard warranty.

Contractor is responsible for the execution and effectiveness of all product warranty requests and any claims, Contractor agrees to respond directly to correct warranty claims and to ensure reconciliation of warranty claims that have been assigned to a third party.

**ARTICLE 29: TERMINATION PROCEDURES**

The Contractor acknowledges that this Master Agreement may be terminated for Convenience or Default. H-GAC will not pay for any expenses incurred after the termination date of the contract.

**A. Convenience**

H-GAC may terminate this Master Agreement at any time, in whole or in part, with or without cause, whenever H-GAC determines that for any reason such termination is in the best interest of H-GAC, by providing written notice by certified mail to the Contractor. Upon receipt of notice of termination, all services hereunder of the Contractor and its employees and subcontractors shall cease to the extent specified in the notice of termination.

The Contractor may cancel or terminate this Master Agreement upon submission of thirty (30) days written notice, presented to H-GAC via certified mail. The Contractor may not give notice of cancellation after it has received notice of default from H-GAC.

**B. Default**

H-GAC may, by written notice of default to the Contractor, terminate the whole or any part of the Master Agreement, in any one of the following circumstances:

- (1) If the Contractor fails to perform the services herein specified within the time specified herein or any extension thereof; or
- (2) If the Contractor fails to perform any of the other provisions of this Master Agreement for any reason whatsoever, or so fails to make progress or otherwise violates the Master Agreements that completion of services herein specified within the Master Agreement term is significantly endangered, and in

either of these two instances does not cure such failure within a period of ten (10) days (or such longer period of time as may be authorized by H-GAC in writing) after receiving written notice by certified mail of default from H-GAC.

- (3) In the event of such termination, Contractor will notify H-GAC of any outstanding Purchase Orders and H-GAC will consult with the End User and notify the Contractor to what extent the End User wishes the Contractor to complete the Purchase Order. If Contractor is unable to do so, Contractor may be subject to a claim for damages from H-GAC and/or the End User.

### **ARTICLE 30: SEVERABILITY**

H-GAC and Contractor agree that should any provision of this Master Agreement be determined to be invalid or unenforceable, such determination shall not affect any other term of this Master Agreement, which shall continue in full force and effect.

### **ARTICLE 31: FORCE MAJEURE**

To the extent that either party to this Master Agreement shall be wholly or partially prevented from the performance of any obligation or duty placed on such party by reason of or through strikes, stoppage of labor, riot, fire, flood, acts of war, insurrection, accident, order of any court, act of God, or specific cause reasonably beyond the party's control and not attributable to its neglect or nonfeasance, in such event, the time for the performance of such obligation or duty shall be suspended until such disability to perform is removed. Determination of force majeure shall rest solely with H-GAC.

### **ARTICLE 32: CONFLICT OF INTEREST**

No officer, member or employee of the Contractor or Contractor's subcontractor, no member of the governing body of the Contractor, and no other public officials of the Contractor who exercise any functions or responsibilities in the review or Contractor approval of this Master Agreement, shall participate in any decision relating to this Master Agreement which affects his or her personal interest, or shall have any personal or pecuniary interest, direct or indirect, in this Master Agreement.

- A. **Conflict of Interest Questionnaire:** Chapter 176 of the Texas Local Government Code requires contractors contracting or seeking to contract with H-GAC to file a conflict-of-interest questionnaire (CIQ) if they have an employment or other business relationship with an H-GAC officer or an officer's close family member. The required questionnaire and instructions are located on the H-GAC website or at the Texas Ethics Commission website <https://www.ethics.state.tx.us/forms/CIQ.pdf>. H-GAC officers include its Board of Directors and Executive Director, who are listed on this website. Respondent must complete and file a CIQ with the Texas Ethics Commission if an employment or business relationship with H-GAC office or an officer's close family member as defined in the law exists.
- B. **Certificate of Interested Parties Form – Form 1295:** As required by Section 2252.908 of the Texas Government Code, H-GAC will not enter a Contract with Contractor unless (i) the Contractor submits a disclosure of interested parties form to H-GAC at the time the Contractor submits the contract to H-GAC, or (ii) the Contractor is exempt from such requirement. The required form and instructions are located at the Texas Ethics Commission website [https://www.ethics.state.tx.us/whatsnew/elf\\_info\\_form1295.htm](https://www.ethics.state.tx.us/whatsnew/elf_info_form1295.htm). Respondents who are awarded a Contract must submit their Form 1295 with the signed Contract to H-GAC.

### **ARTICLE 33: FEDERAL COMPLIANCE**

Contractor agrees to comply with all federal statutes relating to nondiscrimination, labor standards, and environmental compliance. With regards to "Rights to Inventions Made Under a Contract or Master Agreement," If the Federal award meets the definition of "funding Master Agreement" under 37 CFR § 401.2 (a) and the recipient or subrecipient wishes to enter into a contract with a small business firm or nonprofit organization regarding the substitution of parties, assignment or performance of experimental, developmental, or research work under that "funding Master Agreement," the recipient or subrecipient must comply with the requirements of 37 CFR Part 401, "Rights to Inventions Made by Nonprofit Organizations and Small Business Firms Under Government Grants, Contracts and Cooperative Master Agreements," and any implementing regulations issued by the awarding agency. Contractor agrees to be wholly compliant with the provisions of 2 CFR 200, Appendix II. Additionally, for work to be performed under the Master Agreement or subcontract thereof, including procurement

of materials or leases of equipment, Contractor shall notify each potential subcontractor or supplier of the Contractor's federal compliance obligations. These may include, but are not limited to: (a) Title VI of the Civil Rights Act of 1964 (P.L. 88-352) which prohibits discrimination on the basis of race, color or national origin; (b) Title IX of the Education Amendments of 1972, as amended (20 U.S.C. §§ 1681-1683, and 1685-1686), which prohibits discrimination on the basis of sex; (c) the Fair Labor Standards Act of 1938 (29 USC 676 et. seq.), (d) Section 504 of the Rehabilitation Act of 1973, as amended (29 U.S.C. § 794), which prohibits discrimination on the basis of handicaps and the Americans with Disabilities Act of 1990; (e) the Age Discrimination in Employment Act of 1967 (29 USC 621 et. seq.) and the Age Discrimination Act of 1974, as amended (42 U.S.C. §§ 6101-6107), which prohibits discrimination on the basis of age; (f) the Drug Abuse Office and Treatment Act of 1972 (P.L. 92-255), as amended, relating to nondiscrimination on the basis of drug abuse; (g) the Comprehensive Alcohol Abuse and Alcoholism Prevention, Treatment and Rehabilitation Act of 1970 (P.L. 91-616), as amended, relating to the nondiscrimination on the basis of alcohol abuse or alcoholism; (h) §§ 523 and 527 of the Public Health Service Act of 1912 (42 U.S.C. 290 dd-3 and 290 ee-3), as amended, relating to confidentiality of alcohol and drug abuse patient records; (i) Title VIII of the Civil Rights Act of 1968 (42 U.S.C. § 3601 et seq.), as amended, relating to nondiscrimination in the sale, rental or financing of housing; (j) any other nondiscrimination provisions in any specific statute(s) applicable to any Federal funding for this Master Agreement; (k) the requirements of any other nondiscrimination statute(s) which may apply to this Master Agreement; (l) applicable provisions of the Clean Air Act (42 U.S.C. §7401 et seq.), the Federal Water Pollution Control Act, as amended (33 U.S.C. §1251 et seq.), Section 508 of the Clean Water Act (33 U.S.C. 1368), Executive Order 11738, and the Environmental Protection Agency regulations at 40 CFR Part 15; (m) applicable provisions of the Davis- Bacon Act (40 U.S.C. 276a - 276a-7), the Copeland Act (40 U.S.C. 276c), and the Contract Work Hours and Safety Standards Act (40 U.S.C. 327-332), as set forth in Department of Labor Regulations at 20 CFR 5.5a; (n) the mandatory standards and policies relating to energy efficiency which are contained in the state energy conservation plan issued in compliance with the Energy Policy and Conservation Act (P.L. 94-163).

**ARTICLE 34: PROHIBITION ON CONTRACTING WITH ENTITIES USING CERTAIN TELECOMMUNICATIONS AND VIDEO SURVEILLANCE EQUIPMENT (EFFECTIVE AUG. 13, 2020 AND AS AMENDED OCTOBER 26, 2020)**

Pursuant to 2 CFR 200.216, Contractor shall not offer equipment, services, or system that use covered telecommunications equipment or services as a substantial or essential component of any system, or as critical technology as part of any system. Covered telecommunications equipment or services means 1) telecommunications equipment produced by Huawei Technologies Company or ZTE Corporation (or any subsidiary or affiliate of such entities); 2) for the purpose of public safety, security of government facilities, physical security surveillance of critical infrastructure, and other national security purposes, video surveillance and telecommunications equipment produced by Hytera Communications Corporation, Hangzhou Hikvision Digital Technology Company, or Dahua Technology Company (or any subsidiary or affiliate of such entities); 3) telecommunications or video surveillance services provided by such entities or using such equipment; or 4) telecommunications or video surveillance equipment or services produced or provided by an entity that the Secretary of Defense, in consultation with the Director of National Intelligence or the Director of the Federal Bureau of Investigation, reasonably believes to be an entity owned or controlled by, or otherwise connected to, the government of a covered foreign country. Respondent must comply with requirements for certifications. The provision at 48 C.F.R Section 52.204-26 requires that offerors review SAM prior to completing their required representations. This rule applies to all acquisitions, including acquisitions at or below the simplified acquisition threshold and to acquisitions of commercial items, including commercially available off-the-shelf items.

**ARTICLE 35: DOMESTIC PREFERENCE**

In accordance with 2 CFR 200.322, as appropriate and to the extent consistent with law, when using federal grant award funds H-GAC should, to the greatest extent practicable, provide a preference for the purchase, acquisition, or use of goods, products, or materials produced in the United States (including but not limited to iron, aluminum, steel, cement, and other manufactured products). H-GAC must include this requirement in all subawards including all contracts and purchase orders for work or products under the federal grant award. If Contractor intends to qualify for Purchase Orders using federal grant money, then it shall work with H-GAC to provide all required certifications and other documentation needed to show compliance.

**ARTICLE 36: CRIMINAL PROVISIONS AND SANCTIONS**

The Contractor agrees to perform the Master Agreement in conformance with safeguards against fraud and abuse as set forth by the H-GAC, the State of Texas, and the acts and regulations of any related state or federal agency. The Contractor agrees to promptly notify H-GAC of any actual or suspected fraud, abuse, or other criminal activity through the filing of a written report within twenty-four (24) hours of knowledge thereof. Contractor shall notify H-GAC of any accident or incident requiring medical attention arising from its activities under this Master Agreement within twenty-four (24) hours of such occurrence. Theft or willful damage to property on loan to the Contractor from H-GAC, if any, shall be reported to local law enforcement agencies and H-GAC within two (2) hours of discovery of any such act.

The Contractor further agrees to cooperate fully with H-GAC, local law enforcement agencies, the State of Texas, the Federal Bureau of Investigation, and any other duly authorized investigative unit, in carrying out a full investigation of all such incidents.

The Contractor shall notify H-GAC of the threat of lawsuit or of any actual suit filed against the Contractor pertaining to this Master Agreement or which would adversely affect the Contractor's ability to perform services under this Master Agreement.

#### **ARTICLE 37: INDEMNIFICATION AND RECOVERY**

H-GAC's liability under this Master Agreement, whether for breach of contract, warranty, negligence, strict liability, in tort or otherwise, is limited to its order processing charge. In no event will H-GAC be liable for any loss of use, loss of time, inconvenience, commercial loss, lost profits, or savings or other incidental, special or consequential damages to the full extent such use may be disclaimed by law. Contractor agrees, to the extent permitted by law, to defend and hold harmless H-GAC, its board members, officers, agents, officials, employees, and indemnities from any and all claims, costs, expenses (including reasonable attorney fees), actions, causes of action, judgements, and liens arising as a result of Contractor's negligent act or omission under this Master Agreement. Contractor shall notify H-GAC of the threat of lawsuit or of any actual suit filed against Contractor relating to this Master Agreement.

#### **ARTICLE 38: LIMITATION OF CONTRACTOR'S LIABILITY**

Except as specified in any separate writing between the Contractor and an END USER, Contractor's total liability under this Master Agreement, whether for breach of contract, warranty, negligence, strict liability, in tort or otherwise, but excluding its obligation to indemnify H-GAC, is limited to the price of the particular products/services sold hereunder, and Contractor agrees either to refund the purchase price or to repair or replace product(s) that are not as warranted. In no event will Contractor be liable for any loss of use, loss of time, inconvenience, commercial loss, loss of profits or savings or other incidental, special or consequential damages to the full extent such use may be disclaimed by law. Contractor understands and agrees that it shall be liable to repay and shall repay upon demand to END USER any amounts determined by H-GAC, its independent auditors, or any agency of State or Federal government to have been paid in violation of the terms of this Master Agreement.

#### **ARTICLE 39: TITLES NOT RESTRICTIVE**

The titles assigned to the various Articles of this Master Agreement are for convenience only. Titles shall not be considered restrictive of the subject matter of any Article, or part of this Master Agreement.

#### **ARTICLE 40: JOINT WORK PRODUCT**

This Master Agreement is the joint work product of H-GAC and the Contractor. This Master Agreement has been negotiated by H-GAC and the Contractor and their respective counsel and shall be fairly interpreted in accordance with its terms and, in the event of any ambiguities, no inferences shall be drawn against any party.

#### **ARTICLE 41: PROCUREMENT OF RECOVERED MATERIAL**

H-GAC and the Respondent must comply with section 6002 of the Solid Waste Disposal Act, as amended by the Resource Conservation and Recovery Act. The requirements of Section 6002 include: (1) procuring only items designated in guidelines of the Environmental Protection Agency (EPA) at 40 CFR part 247 that contain the highest percentage of recovered materials practicable, consistent with maintaining a satisfactory level of competition, where the purchase price of the item exceeds \$10,000 or the value of the quantity acquired during the preceding fiscal year exceeded \$10,000; (2) procuring solid waste management services in a manner that

maximizes energy and resource recovery; and (3) establishing an affirmative procurement program for procurement of recovered materials identified in the EPA guidelines. Pursuant to the Federal Rule above, as required by the Resource Conservation and Recovery Act of 1976 (42 U.S.C. § 6962(c)(3)(A)(i)), Respondent certifies that the percentage of recovered materials content for EPA-designated items to be delivered or used in the performance of the Contract will be at least the amount required by the applicable contract specifications or other contractual requirements.

**ARTICLE 42: COPELAND “ANTI-KICKBACK” ACT**

Contractor shall comply with 18 U.S.C. § 874, 40 U.S.C. § 3145, and the requirements of 29 C.F.R. pt. 3 as may be applicable, which are incorporated by reference into the contract. The contractor or subcontractor shall insert in any subcontracts the clause above and such other clauses as appropriate agency instructions require, and also a clause requiring the subcontractors to include these clauses in any lower tier subcontracts. The prime contractor shall be responsible for the compliance by any subcontractor or lower tier subcontractor with all of these contract clauses. A breach of the contract clauses above may be grounds for termination of the Contract, and for debarment as a contractor and subcontractor as provided in 29 C.F.R. § 5.12.

**ARTICLE 43: DISCRIMINATION**

Respondent and any potential subcontractors shall comply with all Federal statutes relating to nondiscrimination. These include, but are not limited to:

- a) Title VI of the Civil Rights Act of 1964 (P.L. 88-352), which prohibits discrimination on the basis of race, color, or national origin;
- b) Title IX of the Education Amendments of 1972, as amended (20 U.S.C. §§1681-1683, and 1685-1686), which prohibits discrimination on the basis of sex;
- c) Section 504 of the Rehabilitation Act of 1973, as amended (29 U.S.C. §794), which prohibits discrimination on the basis of handicaps;
- d) The Age Discrimination Act of 1975, as amended (42 U.S.C. §§6101- 6107), which prohibits discrimination on the basis of age;
- e) The Drug Abuse Office and Treatment Act of 1972 (P.L. 92-255), as amended, relating to nondiscrimination on the basis of drug abuse;
- f) The Comprehensive Alcohol Abuse and Alcoholism Prevention, Treatment and Rehabilitation Act of 1970 (P.L. 91-616), as amended, relating to nondiscrimination on the basis of alcohol abuse or alcoholism;
- g) Sections 523 and 527 of the Public Health Service Act of 1912 (42 U.S.C. §§290 dd-3 and 290 ee-3), as amended, relating to confidentiality of alcohol and drug abuse patient records;
- h) Title VIII of the Civil Rights Act of 1968 (42 U.S.C. §3601 et seq.), as amended, relating to nondiscrimination in the sale, rental, or financing of housing;
- i) Any other nondiscrimination provisions in the specific statute(s) under which application for Federal assistance is being made; and
- j) The requirements of any other nondiscrimination statute(s) that may apply to the application.

**ARTICLE 44: DRUG FREE WORKPLACE**

Contractor must provide a drug-free workplace in accordance with the Drug-Free Workplace Act, as applicable. For the purposes of this Section, “drug-free” means a worksite at which employees are prohibited from engaging in the unlawful manufacture, distribution, dispensation, possession, or use of a controlled substance. H-GAC may request a copy of this policy.

**ARTICLE 45: APPLICABILITY TO SUBCONTRACTORS**

Respondent agrees that all contracts it awards pursuant to the contract awarded as a result of this Master Agreement will be bound by the foregoing terms and conditions.

**ARTICLE 46: WARRANTY AND COPYRIGHT**

Submissions must include all warranty information, including items covered, items excluded, duration, and renewability. Submissions must include proof of licensing if using third party code for programming.

**ARTICLE 47: DATA HANDLING AND SECURITY**

It will always be the responsibility of the selected Contractor to manage data transfer and to secure all data appropriately during the project to prevent unauthorized access to all data, products, and deliverables.

**ARTICLE 48: DISPUTES**

All disputes concerning questions of fact or of law arising under this Master Agreement, which are not addressed within the Whole Master Agreement as defined pursuant to Article 4 hereof, shall be decided by the Executive Director of H-GAC or his designee, who shall reduce his decision to writing and provide notice thereof to the Contractor. The decision of the Executive Director or his designee shall be final and conclusive unless, within thirty (30) days from the date of receipt of such notice, the Contractor requests a rehearing from the Executive Director of H-GAC. In connection with any rehearing under this Article, the Contractor shall be afforded an opportunity to be heard and offer evidence in support of its position. The decision of the Executive Director after any such rehearing shall be final and conclusive. The Contractor may, if it elects to do so, appeal the final and conclusive decision of the Executive Director to a court of competent jurisdiction. Pending final decision of a dispute hereunder, the Contractor shall proceed diligently with the performance of the Master Agreement and in accordance with H-GAC's final decision.

**ARTICLE 49: CHOICE OF LAW: VENUE**

This Master Agreement shall be governed by the laws of the State of Texas. Venue and jurisdiction of any suit or cause of action arising under or in connection with the Master Agreement shall lie exclusively in Harris County, Texas. Disputes between END USER and Contractor are to be resolved in accordance with the law and venue rules of the state of purchase. Contractor shall immediately notify H-GAC of such disputes.

**ARTICLE 50: ORDER OF PRIORITY**

In the case of any conflict between or within this Master Agreement, the following order of priority shall be utilized: 1) General Provisions, 2) Special Provisions, 3) Scope of Work, and 4) Other Attachments.

**ARTICLE 51: WHOLE MASTER AGREEMENT**

**Please note, this is an H-GAC Master Agreement template and is used for all products and services offered in H-GAC Cooperative Purchasing. Any redlines to this Master Agreement may not be reviewed. If this Master Agreement has not been signed by the Contractor within 30 calendar days, this Master Agreement will be automatically voided.** The Master General Provisions, Master Special Provisions, and Attachments, as provided herein, constitute the complete Master Agreement between the parties hereto, and supersede any and all oral and written Master Agreements between the parties relating to matters herein. Except as otherwise provided herein, this Master Agreement cannot be modified without written consent of the parties.

**ARTICLE 52: UNIVERSAL IDENTIFIER AND SYSTEM FOR AWARD MANAGEMENT (SAM)**

In accordance with 2 CFR Title 2, Subtitle A, Chapter I, Part 25 as it applies to a Federal awarding agency's grants, cooperative agreements, loans, and other types of Federal financial assistance as defined in 2 CFR 25.406. Contractor understands and as it relates to 2 CFR 25.205(a), a Federal awarding agency may not make a Federal award or financial modification to an existing Federal award to an applicant or recipient until the entity has complied with the requirements described in 2 CFR 25.200 to provide a valid unique entity identifier and maintain an active SAM registration ([www.SAM.gov](http://www.SAM.gov)) with current information (other than any requirement that is not applicable because the entity is exempted under § 25.110). 2 CFR 25.200(b) requires that registration in the SAM **prior to submitting an application or plan**; and maintain an active SAM registration with current information, including information on a recipient's immediate and highest level owner and subsidiaries, as well as on all predecessors that have been awarded a Federal contract or grant within the last three years, if applicable, at all

times during which it has an active Federal award or an application or plan under consideration by a Federal awarding agency; and provide its unique entity identifier in each application or plan it submits to the Federal awarding agency. To remain registered in the SAM database after the initial registration, the applicant is required to review and update its information in the SAM database on an annual basis from the date of initial registration or subsequent updates to ensure it is current, accurate and complete. At the time a Federal awarding agency is ready to make a Federal award, if the intended recipient has not complied with an applicable requirement to provide a unique entity identifier or maintain an active SAM registration with current information, the Federal awarding agency: (1) May determine that the applicant is not qualified to receive a Federal award; and (2) May use that determination as a basis for making a Federal award to another applicant.

**ARTICLE 53: PROCUREMENT OF RECOVERED MATERIALS**

In accordance with 2 CFR 200.323, the Houston-Galveston Area Council and the Contractor or Subrecipient must comply with section 6002 of the Solid Waste Disposal Act, as amended by the Resource Conservation and Recovery Act. The requirements of Section 6002 include: (1) procuring only items designated in guidelines of the Environmental Protection Agency (EPA) at 40 CFR part 247 that contain the highest percentage of recovered materials practicable, consistent with maintaining a satisfactory level of competition, where the purchase price of the item exceeds \$10,000 or the value of the quantity acquired during the preceding fiscal year exceeded \$10,000; (2) procuring solid waste management services in a manner that maximizes energy and resource recovery; and (3) establishing an affirmative procurement program for procurement of recovered materials identified in the EPA guidelines. Pursuant to the Federal Rule above, as required by the Resource Conservation and Recovery Act of 1976 (42 U.S.C. § 6962(c)(3)(A)(i)), the Contractor or Subrecipient certifies that the percentage of recovered materials content for EPA-designated items to be delivered or used in the performance of the Agreement will be at least the amount required by the applicable contract specifications or other contractual requirements.

**SIGNATURES:**

H-GAC and the Contractor have read, agreed, and executed the whole Master Agreement as of the date first written above, as accepted by:

**Siddons Martin Emergency Group LLC**

**H-GAC**

Signature 

Signature

Name Kathryn Williams

Name Chuck Wemple

Title Vice President

Title Executive Director

Date 12/11/2023

Date

# H-GAC

Houston-Galveston Area Council

P.O. Box 22777 · 3555 Timmons · Houston, Texas 77227-2777

---

Cooperative Agreement - Contract - Siddons Martin Emergency Group LLC - Public Services - ID: 11564

## MASTER SPECIAL PROVISIONS

**Please note, this is an H-GAC Master Agreement template and is used for all products and services offered in H-GAC Cooperative Purchasing. Any redlines to this Master Agreement may not be reviewed.** Incorporated by attachment, as part of the whole Master Agreement, H-GAC and the Contractor do, hereby agree to the Master Special Provisions as follows:

### **ARTICLE 1: BIDS/PROPOSALS INCORPORATED**

In addition to the whole Master Agreement, the following documents listed in order of priority are incorporated into the Master Agreement by reference: Bid/Proposal Specifications and Contractor's Response to the Bid/Proposal.

### **ARTICLE 2: END USER MASTER AGREEMENTS ("EUA")**

H-GAC acknowledges that the END USER, which is the HGAC Buy customer utilizing the contract (CUSTOMER and END USER may be used interchangeably) may choose to enter into an End User Master Agreement (EUA) with the Contractor through this Master Agreement. A CUSTOMER/END USER is a state agency, county, municipality, special district, or other political subdivision of a state, or a qualifying non-profit corporation (providing one or more governmental function or service that possess legal authority to enter into the Contract. The term of the EUA may exceed the term of the current H-GAC Master Agreement.

H-GAC's acknowledgement is not an endorsement or approval of the End User Master Agreement's terms and conditions. Contractor agrees not to offer, agree to or accept from the CUSTOMER/END USER, any terms or conditions that conflict with those in Contractor's Master Agreement with H-GAC. Contractor affirms that termination of its Master Agreement with H-GAC for any reason shall not result in the termination of any underlying EUA, which shall in each instance, continue pursuant to the EUA's stated terms and duration. Pursuant to the terms of this Master Agreement, termination of this Master Agreement will disallow the Contractor from entering into any new EUA with CUSTOMER/END USER. Applicable H-GAC order processing charges will be due and payable to H-GAC on any EUAs, surviving termination of this Master Agreement between H-GAC and Contractor.

### **ARTICLE 3: MOST FAVORED CUSTOMER CLAUSE**

Contractor shall provide its most favorable pricing and terms to H-GAC. If at any time during this Master Agreement, Contractor develops a regularly followed standard procedure of entering into Master Agreements with other governmental customers within the State of Texas, and offers the same or substantially the same products/services offered to H-GAC on a basis that provides prices, warranties, benefits, and or terms more favorable than those provided to H-GAC, Contractor shall notify H-GAC within ten (10) business days thereafter, and this Master Agreement shall be deemed to be automatically retroactively amended, to the effective date of Contractor's most favorable past Master Agreement with another entity. Contractor shall provide the same prices, warranties, benefits, or terms to H-GAC and its CUSTOMER/END USER as provided in its most favorable past Master Agreement. H-GAC shall have the right and option at any time to decline to accept any such change, in which case the amendment shall be deemed null and void. If Contractor claims that a more favorable price, warranty, benefit, or term that was charged or offered to another entity during the term of this Master Agreement, does not constitute more favorable treatment, than Contractor shall, within ten (10) business days, notify H-GAC in writing, setting forth the detailed reasons Contractor believes the aforesaid

offer is not in fact most favored treatment. H-GAC, after due consideration of Contractor's written explanation, may decline to accept such explanation and thereupon this Master Agreement between H-GAC and Contractor shall be automatically amended, effective retroactively, to the effective date of the most favored Master Agreement, to provide the same prices, warranties, benefits, or terms to H-GAC and the CUSTOMER/END USER.

**EXCEPTION:** This clause shall not be applicable to prices and price adjustments offered by a bidder, proposer, or contractor, which are not within bidder's/proposer's control [example; a manufacturer's bid concession], or to any prices offered to the Federal Government and its agencies.

#### **ARTICLE 4: PARTY LIABILITY**

Contractor's total liability under this Master Agreement, whether for breach of contract, warranty, negligence, strict liability, in tort or otherwise, is limited to the price of the particular products/services sold hereunder. Contractor agrees either to refund the purchase price or to repair or replace product(s) that are not as warranted. Contractor accepts liability to repay, and shall repay upon demand to CUSTOMER/END USER, any amounts determined by H-GAC, its independent auditors, or any state or federal agency, to have been paid in violation of the terms of this Master Agreement.

#### **ARTICLE 5: GOVERNING LAW & VENUE**

Contractor and H-GAC agree that Contractor will make every reasonable effort to resolve disputes with the CUSTOMER/END USER in accord with the law and venue rules of the state of purchase. Contractor shall immediately notify H-GAC of such disputes.

#### **ARTICLE 6: SALES AND ORDER PROCESSING CHARGE**

Contractor shall sell its products to CUSTOMER/END USER based on the pricing and terms of this Master Agreement. H-GAC will invoice Contractor for the applicable order processing charge when H-GAC receives notification of a CUSTOMER/END USER order. Contractor shall remit to H-GAC the full amount of the applicable order processing charge, after delivery of any product or service and subsequent CUSTOMER/END USER acceptance. Payment of the Order Processing Charge shall be remitted from Contractor to H-GAC, within thirty (30) calendar days or ten (10) business days after receipt of a CUSTOMER/END USER's payment, whichever comes first, notwithstanding Contractor's receipt of invoice. For sales made by Contractor based on this Master Agreement, including sales to entities without Interlocal Master Agreements, Contractor shall pay the applicable order processing charges to H-GAC. Further, Contractor agrees to encourage entities who are not members of H-GAC's Cooperative Purchasing Program to execute an H-GAC Interlocal Master Agreement. H-GAC reserves the right to take appropriate actions including, but not limited to, Master Agreement termination if Contractor fails to promptly remit the appropriate order processing charge to H-GAC. In no event shall H-GAC have any liability to Contractor for any goods or services a CUSTOMER/END USER procures from Contractor. At all times, Contractor shall remain liable to pay to H-GAC any order processing charges on any portion of the Master Agreement actually performed, and for which compensation was received by Contractor.

#### **ARTICLE 7: LIQUIDATED DAMAGES**

Contractor and H-GAC agree that Contractor shall cooperate with the CUSTOMER/END USER at the time a CUSTOMER/END USER purchase order is placed, to determine terms for any liquidated damages.

#### **ARTICLE 8: INSURANCE**

Unless otherwise stipulated in Section B of the Bid/Proposal Specifications, Contractor must have the following insurance and coverage minimums:

- a. General liability insurance with a Single Occurrence limit of at least \$1,000,000.00, and a General Aggregate limit of at least two times the Single Occurrence limit.
- b. Product liability insurance with a Single Occurrence limit of at least \$1,000,000.00, and a General Aggregate limit of at least two times the Single Occurrence limit for all Products except Automotive Fire Apparatus. For Automotive Fire Apparatus, see Section B of the Bid/Proposal Specifications.
- c. Property Damage or Destruction insurance is required for coverage of End User owned equipment while in Contractor's possession, custody, or control. The minimum Single Occurrence limit is \$500,000.00 and the General Aggregate limit must be at least two times the Single Occurrence limit. This insurance may be carried in several ways, e.g. under an Inland Marine policy, as art of Automobile coverage, or under a Garage Keepers policy. In any event, this coverage must be specifically and clearly listed on insurance certificate(s) submitted to H-GAC.
- d. Insurance coverage shall be in effect for the length of any contract made pursuant to the Bid/Proposal, and for any extensions thereof, plus the number of days/months required to deliver any outstanding order after the close of the contract period.
- e. Original Insurance Certificates must be furnished to H-GAC on request, showing Contractor as the insured and showing coverage and limits for the insurances listed above.
- f. If any Product(s) or Service(s) will be provided by parties other than Contractor, all such parties are required to carry the minimum insurance coverages specified herein, and if requested by H-GAC, a separate insurance certificate must be submitted for each such party.
- g. H-GAC reserves the right to contact insurance underwriters to confirm policy and certificate issuance and document accuracy.

#### **ARTICLE 9: PERFORMANCE AND PAYMENT BONDS FOR INDIVIDUAL ORDERS**

H-GAC's contractual requirements DO NOT include a Performance & Payment Bond (PPB); therefore, Contractor shall offer pricing that reflects this cost savings. Contractor shall remain prepared to offer a PPB to cover any order if so requested by the CUSTOMER/END USER. Contractor shall quote a price to CUSTOMER/END USER for provision of any requested PPB, and agrees to furnish the PPB within ten business (10) days of receipt of CUSTOMER/END USER's purchase order.

#### **ARTICLE 10: ORDER PROCESSING CHARGE**

H-GAC will apply an Order Processing Charge for each sale done through the H-GAC contract, with the exception of orders for motor vehicles. Any pricing submitted must include this charge amount per the most current H-GAC schedule. For motor vehicle orders, the Processing Charge is paid by the CUSTOMER/END USER. Contractor will need to refer to the solicitation for the Order Processing Charge.

#### **ARTICLE 11: CHANGE OF STATUS**

Contractor shall immediately notify H-GAC, in writing, of ANY change in ownership, control, dealership/franchisee status, Motor Vehicle license status, or name. Contractor shall offer written guidance to advise H-GAC if this Master Agreement shall be affected in any way by such change. H-GAC shall have the right to determine whether or not such change is acceptable, and to determine what action shall be warranted, up to and including cancellation of Master Agreement.

#### **ARTICLE 12: REQUIREMENTS TO APPLICABLE PHYSICAL GOODS**

In the case of physical goods (e.g. equipment, material, supplies, as opposed to services), all Products offered must comply with any applicable provisions of the Texas Business and Commerce Code, Title 1, Chapter 2 and with at least the following:

- a. Be new, unused, and not refurbished.
- b. Not be a prototype as the general design, operation, and performance. This requirement is NOT meant to preclude the Contractor from offering new models or configurations which incorporate improvements in a current design or add functionality, but in which new model or configuration may be new to the marketplace.
- c. Include all accessories which may or may not be specifically mentioned in the Master Agreement, but which are normally furnished or necessary to make the Product ready for its intended use upon delivery. Such accessories shall be assembled, installed, and adjusted to allow continuous operation of Product at time of delivery.
- d. Have assemblies, sub-assemblies and component parts that are standard and interchangeable throughout the entire quantity of a Product as may be purchased simultaneously by any END USER/CUSTOMER.
- e. Be designed and constructed using current industry accepted engineering and safety practices, and materials.
- f. Be available for inspection at any time prior to or after procurement.

#### **ARTICLE 13: TEXAS MOTOR VEHICLE BOARD LICENSING**

All Contractors that deal in motor vehicles shall maintain current licenses that are required by the Texas Motor Vehicle Commission Code. If at any time during this Master Agreement term, any required Contractor license is denied, revoked, or not renewed, Contractor shall be in default of this Master Agreement, unless the Texas Motor Vehicle Board issues a stay or waiver. Contractor shall promptly provide copies of all current applicable Texas Motor Vehicle Board documentation to H-GAC upon request.

#### **ARTICLE 14: INSPECTION/TESTING**

All Products sold pursuant to this Master Agreement will be subject to inspection/testing by or at the direction of H-GAC and/or the ordering CUSTOMER/END USER, either at the delivery destination or the place of manufacture. In the event a Product fails to meet or exceed all requirements of this Master Agreement, and unless otherwise agreed in advance, the cost of any inspection and/or testing, will be the responsibility of the Contractor.

#### **ARTICLE 15: ADDITIONAL REPORTING REQUIREMENTS**

Contractor agrees to submit written quarterly reports to H-GAC detailing all transactions during the previous three (3) month period. Reports must include, but are not limited, to the following information:

- a. CUSTOMER/END USER Name
- b. Product/Service purchased, including Product Code if applicable
- c. Customer Purchase Order Number
- d. Purchase Order Date
- e. Product/Service dollar amount
- f. HGACBuy Order Processing Charge amount

#### **ARTICLE 16: BACKGROUND CHECKS**

Cooperative customers may request background checks on any awarded contractor's employees who will have direct contact with students, or for any other reason they so choose, any may require contractor to pay the cost of obtaining any background information requested by the CUSTOMER/END USER.

#### **ARTICLE 17: PROHIBITION ON CONTRACTS WITH COMPANIES BOYCOTTING ISRAEL CERTIFICATION**

As required by Chapter 2271 of the Texas Local Government Code the Contractor must verify that it 1) does not boycott Israel; and 2) will not boycott Israel during the term of the Contract. Pursuant to Section 2271.001, Texas Government Code:

1. "Boycott Israel" means refusing to deal with, terminating business activities with, or otherwise taking any action that is intended to penalize, inflict economic harm on, or limit commercial relations specifically with Israel, or with a person or entity doing business in Israel or in an Israeli-controlled territory, but does not include an action made for ordinary business purposes; and

2. "Company" means a for-profit sole proprietorship, organization, association, corporation, partnership, joint venture, limited partnership, limited liability partnership, or any limited liability company, including a wholly owned subsidiary, majority-owned subsidiary, parent company or affiliate of those entities or business associations that exist to make a profit.

**ARTICLE 18: NO EXCLUDED NATION OR TERRORIST ORGANIZATION CERTIFICATION**

As required by Chapter 2252 of the Texas Government Code the Contractor must certify that it is not a company engaged in active business operations with Sudan, Iran, or a foreign terrorist organization – specifically, any company identified on a list prepared and maintained by the Texas Comptroller under Texas Government Code §§806.051, 807.051, or 2252.153. (A company that the U.S. Government affirmatively declares to be excluded from its federal sanctions regime relating to Sudan, Iran, or any federal sanctions regime relating to a foreign terrorist organization is not subject to the contract prohibition.)

**ARTICLE 19: PROHIBITION ON CONTRACTING WITH ENTITIES USING CERTAIN TELECOMMUNICATIONS AND VIDEO SURVEILLANCE EQUIPMENT (Effective Aug. 13, 2020 and as amended October 26, 2020)**

Pursuant to 2 CFR 200.216, Contractor shall not offer equipment, services, or system that use covered telecommunications equipment or services as a substantial or essential component of any system, or as critical technology as part of any system. "Covered telecommunications equipment or services means 1) telecommunications equipment produced by Huawei Technologies Company or ZTE Corporation (or any subsidiary or affiliate of such entities); 2) for the purpose of public safety, security of government facilities, physical security surveillance of critical infrastructure, and other national security purposes, video surveillance and telecommunications equipment produced by Hytera Communications Corporation, Hangzhou Hikvision Digital Technology Company, or Dahua Technology Company (or any subsidiary or affiliate of such entities); 3) telecommunications or video surveillance services provided by such entities or using such equipment; or 4) telecommunications or video surveillance equipment or services produced or provided by an entity that the Secretary of Defense, in consultation with the Director of National Intelligence or the Director of the Federal Bureau of Investigation, reasonably believes to be an entity owned or controlled by, or otherwise connected to, the government of a covered foreign country.

Contractor must comply with requirements for certifications. The provision at 48 C.F.R Section 52.204-26 requires that Contractors review SAM prior to completing their required representations. This rule applies to all acquisitions, including acquisitions at or below the simplified acquisition threshold and to acquisitions of commercial items, including commercially available off the-shelf items.

**ARTICLE 20: BUY AMERICA ACT (National School Lunch Program and Breakfast Program)**

With respect to products purchased by CUSTOMER/END USER for use in the National School Lunch Program and/or National School Breakfast Program, Contractor shall comply with all federal procurement laws and regulations with respect to such programs, including the Buy American provisions set forth in 7 C.F.R. Part 210.21(d), to the extent applicable. Contractor agrees to provide all certifications required by CUSTOMER/END USER regarding such programs.

In the event Contractor or Contractor's supplier(s) are unable or unwilling to certify compliance with the Buy American Provision, or the applicability of an exception to the Buy American provision, H-GAC CUSTOMER/END USER may decide not to purchase from Contractor. Additionally, H-GAC

CUSTOMER/END USER may require country of origin on all products and invoices submitted for payment by Contractor, and Contractor agrees to comply with any such requirement.

**ARTICLE 21: BUY AMERICA REQUIREMENT (Applies only to Federally Funded Highway and Transit Projects)**

With respect to products purchased by CUSTOMER/END USER for use in federally funded highway projects, Contractor shall comply with all federal procurement laws and regulations with respect to such projects, including the Buy American provisions set forth in 23 U.S.C. Section 313, 23 C.F.R. Section 635.410, as amended, and the Steel and Iron Preference provisions of Texas Transportation Code Section 223.045, to the extent applicable. Contractor agrees to provide all certifications required by CUSTOMER/END USER regarding such programs. With respect to products purchased by CUSTOMER/END USER for use in federally funded transit projects, Contractor shall comply with all federal procurement laws and regulations with respect to such projects, including the Buy American provisions set forth in 49 U.S.C. Section 5323(j)(1), 49 C.F.R. Sections 661.6 or 661.12, to the extent applicable. Contractor agrees to provide all certifications required by CUSTOMER/END USER regarding such programs.

**ARTICLE 22: DOMESTIC PREFERENCE**

In accordance with 2 CFR 200.322, as appropriate and to the extent consistent with law, a CUSTOMER/END USER using federal grant award funds should, to the greatest extent practicable, provide a preference for the purchase, acquisition, or use of goods, products, or materials produced in the United States (including but not limited to iron, aluminum, steel, cement, and other manufactured products). The CUSTOMER/END USER must include this requirement in all subawards including all contracts and purchase orders for work or products under the federal grant award. If Contractor intends to qualify for Purchase Orders using federal grant money, they shall work with the CUSTOMER/END USER to provide all required certifications and other documentation needed to show compliance.

**ARTICLE 23: TITLE VI REQUIREMENTS**

H-GAC in accordance with the provisions of Title VI of the Civil Rights Act of 1964 (78 Stat. 252, 42 U.S.C. §§ 2000d to 2000d-4) and the Regulations, hereby notifies all bidders that it will affirmatively ensure that any disadvantaged business enterprises will be afforded full and fair opportunity to submit in response to this Master Agreement and will not be discriminated against on the grounds of race, color, or national origin in consideration for an award.

**ARTICLE 24: EQUAL EMPLOYMENT OPPORTUNITY**

Except as otherwise provided under 41 CFR Part 60, all Contracts and CUSTOMER/END USER Purchase Orders that meet the definition of "federally assisted construction contract" in 41 CFR Part 60-1.3 shall be deemed to include the equal opportunity clause provided under 41 CFR 60-1.4(b), in accordance with Executive Order 11246, "Equal Employment Opportunity" (30 FR 12319, 12935, 3 CFR Part, 1964-1965 Comp., pg.339), as amended by Executive Order 11375, "Amending Executive Order 11246 Relating to Equal Employment Opportunity," and implementing regulations at 41CFR Part 60, "Office of Federal Contract Compliance Programs, Equal Employment Opportunity, Department of Labor."

The equal opportunity clause provided under 41 CFR 60-1.4(b) is hereby incorporated by reference. Contractor agrees that such provision applies to any contract that meets the definition of "federally assisted construction contract" in 41 CFR Part 60-1.3 and agrees that it will comply with such provision.

**ARTICLE 25: CLEAN AIR AND WATER POLLUTION CONTROL ACT**

CUSTOMER/END USER Purchase Orders using federal funds must contain a provision that requires the Contractor to agree to comply with all applicable standards, orders or regulations issued pursuant to the Clean

Air Act (42 U.S.C. 7401-7671q) and the Federal Water Pollution Control Act as amended (33 U.S.C. 1251-1387). Violations must be reported to the Federal awarding agency and the Regional Office of the Environmental Protection Agency (EPA).

Pursuant to the Federal Rule above, Contractor certifies that it is in compliance with all applicable provisions of the Clean Air Act (42 U.S.C. 7401-7671q) and the Federal Water Pollution Control Act as amended (33 U.S.C. 1251-1387) and will remain in compliance during the term of the Contract.

**ARTICLE 26: PREVAILING WAGE**

Contractor and any potential subcontractors have a duty to and shall pay the prevailing wage rate under the Davis-Bacon Act, 40 U.S.C. 276a – 276a-5, as amended, and the regulations adopted thereunder contained in 29 C.F.R. pt. 1 and 5.

**ARTICLE 27: CONTRACT WORK HOURS AND SAFETY STANDARDS**

As per the Contract Work Hours and Safety Standards Act (40 U.S.C. 3701-3708), where applicable, all CUSTOMER/END USER Purchase Orders in excess of \$100,000 that involve the employment of mechanics or laborers must include a provision for compliance with 40 U.S.C. 3702 and 3704, as supplemented by Department of Labor regulations (29 CFR Part 5). Under 40 U.S.C. 3702 of the Act, each contractor must be required to compute the wages of every mechanic and laborer, on the basis of a standard work week of 40 hours. Work in excess of the standard work week is permissible provided that the worker is compensated at a rate of not less than one and a half times the basic rate of pay for all hours worked in excess of 40 hours in the work week. The requirements of 40 U.S.C. 3704 are applicable to construction work and provide that no laborer or mechanic must be required to work in surroundings or under working conditions which are unsanitary, hazardous, or dangerous. These requirements do not apply to the purchases of supplies or materials or articles ordinarily available on the open market, or contracts for transportation or transmission of intelligence.

**ARTICLE 28: PROFIT AS A SEPARATE ELEMENT OF PRICE**

For purchases using federal funds more than the current Simplified Acquisition Threshold of \$250,000, requires negotiation of profit as a separate element of the price. See, 2 CFR 200.324(b). Contractor agrees to provide information and negotiate regarding profit as a separate element of the price for the purchase. Contractor also agrees that the total price, including profit, charged by Contractor will not exceed the awarded pricing, including any applicable discount, under any awarded contract.

**ARTICLE 29: BYRD ANTI-LOBBYING AMENDMENT**

Byrd Anti-Lobbying Amendment (31 U.S.C. 1352) – Contractors that apply or bid for an award exceeding \$100,000 must file the required anti-lobbying certification. Each tier must certify to the tier above that it will not and has not used Federal appropriated funds to pay any person or organization for influencing or attempting to influence an officer or employee of any agency, a member of Congress, officer or employee of Congress, or an employee of a member of Congress in connection with obtaining any Federal contract, grant or any other award covered by 31 U.S.C. 1352. Each tier must also disclose any lobbying with non-Federal funds that takes place in connection with obtaining any Federal award. Such disclosures are forwarded from tier to tier, up to the CUSTOMER/END USER. As applicable, Contractor agrees to file all certifications and disclosures required by, and otherwise comply with, the Byrd Anti-Lobbying Amendment (31 USC 1352). Contractor certifies that it is currently in compliance with all applicable provisions of the Byrd Anti-Lobbying Amendment (31 U.S.C. 1352) and will continue to be in compliance throughout the term of the Contract and further certifies that:

1. No Federal appropriated funds have been paid or will be paid by or on behalf of the Contractor, to any person for influencing or attempting to influence an officer or employee of any agency, a Member of Congress, an officer or employee of Congress, or an employee of a Member of Congress in connection

with the awarding of a Federal contract, the making of a Federal Grant, the making of a Federal Loan, the entering into a cooperative Master Agreement, and the extension, continuation, renewal, amendment, or modification of a Federal contract, grant, loan, or cooperative Master Agreement.

2. If any funds other than Federal appropriated funds have been paid or will be paid to any person for influencing, or attempting to influence, an officer or employee of a Member of Congress in connection with a Federal contract, grant, loan, or cooperative Master Agreement, Contractor shall complete and submit Standard Form – LLL, “Disclosure Form to Report Lobbying”, in accordance with its instructions.
3. Contractor shall require that the language of this certification be included in the award documents for all subawards at all tiers (including subcontracts, subgrants, and contracts under grants, loans, and cooperative Master Agreements) and that all subcontractors shall certify and disclose accordingly.

This certification is a material representation of fact upon which reliance was placed when this transaction was made or entered into. Submission of this certificate is a prerequisite for making or entering into this transaction imposed by Section 1352, title 31, U.S. Code. Any person who fails to file the required certification shall be subject to a civil penalty of not less than \$10,000 and not more than \$100,000 for each such failure.

**ARTICLE 30: COMPLIANCE WITH EPA REGULATIONS APPLICABLE TO GRANTS, SUBGRANTS, COOPERATIVE MASTER AGREEMENTS, AND CONTRACTS**

Contractor certifies compliance with all applicable standards, orders, regulations, and/or requirements issued pursuant to the Clean Air Act of 1970, as amended (42 U.S.C. 1857(h)), Section 508 of the Clean Water Act, as amended (13 U.S.C. 1368), Executive Order 117389 and Environmental Protection Agency Regulation, 40 CFR Part 15.

**ARTICLE 31: COMPLIANCE WITH ENERGY POLICY AND CONSERVATION ACT**

Contractor certifies that Contractor will be in compliance with mandatory standards and policies relating to energy efficiency which are contained in the state energy conservation plan issued in compliance with the Energy Policy and Conservation Act (Pub. L. 94-163, 89 Stat. 871).

# Fire Apparatus and Related Vehicles

Request For Proposal

HGACBuy/Cooperative Purchasing Program

07230

**Project ID:** FS12-23

**Release Date:** Wednesday, July 26, 2023

- **Due Date:** Thursday, September 14, 2023 12:00pm

Posted Wednesday, July 26, 2023 7:00am

Bid Unsealed Thursday, September 14, 2023 12:05pm

Pricing Unsealed Thursday, September 14, 2023 12:05pm

## 4. Specifications/Categories/Scope of Work

*This is an indefinite quantity/indefinite delivery offerings contract. The HGACBuy Customer is responsible to ensure adequate competition is performed between the various contractors or contractors outside of HGACBuy to determine price reasonableness that might be required per any funding agency. Customer will need to ensure compliance with any funding agency requirements before proceeding with a purchase order under this contract. Please consult legal counsel regarding questions concerning compliance as a contractor under this solicitation.*

### 4.1. Overview

H-GAC is soliciting responses for selecting qualified manufacturers, dealers, distributors, and service providers of Fire Apparatus and Other Special Service Vehicles and related services to make these types of products and services available to Customers of the HGACBuy Cooperative Purchasing Program under blanket type contracts.

Customers (end users) may require selective acquisitions of equipment and/or services OR full turnkey projects necessitating additional services, training, and maintenance agreements. H-GAC is seeking the broadest possible selection of available fire apparatus and special service vehicles to best serve our customers by providing the largest selection of products/services available to meet their needs. This solicitation may include a request for a discount percent off price catalog, category, or manufacturer, or price list for supplies, materials, or not to exceed hourly rates for installation or repair. Respondents are not required to provide offerings on all categories. Please note: awarded contracts for FS12-23 allow contractors to update their manufacturer pricing and product offerings at any time during the course of the four-year contract term.

### 4.2. Categories

This Solicitation is divided into twelve (12) separate but related product categories (A-L). When submitting a response, Respondent may choose to submit a response to any of the categories or all of them. No additional weighted value will be assigned to a response that addresses more than one or all categories listed. All equipment must be the manufacturer's new and current model and must be fully operational upon delivery to the Customer.

This solicitation does not include ambulances - please see HGACBuy Contract AM10-20 and AM10-23.

Alternative Fuel Vehicles: All responses that include electric, hybrid, or other alternative fuel vehicles must include these vehicles in Category I. If that specific vehicle is also available with an internal combustion engine (ICE),

please list the ICE vehicle separately in the appropriate vehicle category. Category I will only include the alternative fuel vehicles, regardless of vehicle function or type.

Product categories are as follows:

**A. Wildland Fire Apparatus - Brush Fire, Off-Road Tenders/Tankers, Crew Carriers, Slip-in Units, etc.**

Response listings/descriptions must be organized by major sub-categories, which include Manufacturer, type/function, model, chassis (make and model), cab configuration, 2WD/4WD, and fuel type, and tank and pump.

**B. Aerial Fire Apparatus - Boom/Platform, Ladder, Ladder/Platform, etc.**

Response listings/descriptions must be organized by major sub-categories, which include Manufacturer, model, chassis, aerial category/construction, aerial functions, cab types, and axle configurations.

**C. Pumper Fire Apparatus**

Response listings/descriptions must be organized by major sub-categories, which include Manufacturer, model, chassis, cab types, axle configurations, tank capacities/construction, and pump capacity/position.

**D. Pumper-Tanker/Tanker/Tender Fire Apparatus**

Response listings/descriptions must be organized by major sub-categories, which include Manufacturer, model, chassis, cab types, axle configurations, tank capacities/construction, and pump capacity/position.

**E. Aircraft Rescue & Fire-Fighting Vehicles (ARFF)**

Response listings/descriptions must be organized by major sub-categories including Manufacturer, model, chassis, cab types, axle configurations, and by Class Types 1-5.

**F. Special Service Apparatus – Rescue/Fast Response, Re-Hab, Hazmat, Mobile Emergency Command/Communication Centers/Trailers, Light/Air Vehicle, Dive Response Vehicle, ATV/UTV Response Vehicles, Mobile Fire Pump Testers, etc.**

Response listings/descriptions must be organized by Manufacturer, function, type, or purpose of the apparatus/vehicle, and include brief and concise details about the vehicle.

**G. Fire Boats, Rescue Boats, Emergency Response Boats**

Response listings/descriptions must be organized by major sub-categories including Manufacturer, type, function, size, and propulsion.

**H. Fire Command Vehicles - Light, medium, and heavy-duty pickups and SUVs**

Response listings/descriptions must be organized by major sub-categories including Manufacturer, model, chassis, and 2WD/4WD, fuel type.

### **I. Electric/Alternative Fuel Fire Apparatus**

Response listings/descriptions must be organized by major sub-categories including Manufacturer, model, chassis, vehicle type, fuel/propulsion type, and function.

### **J. Fire Apparatus/Vehicle Service/Maintenance Plans**

Response listings/descriptions must include plan details, including details about which fees are included in costs, and items such as labor rates, and fee structures.

### **K. Fire Apparatus/Vehicle Parts and Supplies**

Response listing need only to include percentage discount.

### **L. Fire Apparatus/Vehicle Options**

Please provide a complete listing or catalog of options, accessories, and loose equipment offered. Please clearly indicate if the options are model or vehicle specific, or only available for specific models or vehicles. Options must be clearly identified as upgrades or downgrades and clearly show the net effect to the price of the base model. (Please upload in Section 9.1.4 Required Documents.)

## **4.3. General Requirements**

All products priced and sold pursuant to this Solicitation must, as applicable:

1. Meet all applicable requirements of federal, state and local laws and regulations.
2. Be manufacturer's normal offering with all standard features and functions and performance levels.
3. Be ready for turn-key operation upon delivery.
4. Respondent must include specifications, brochures, warranty information, and any other relevant product information with solicitation Response.

Note: "Unpriced/unpublished" options cannot be quoted on the Base Pricing List and may not be sold through this contract.

## **4.4. Additional Requirements**

### **Licenses**

1. Contractor must have and maintain the appropriate license(s) as required by the State of Texas, Department of Transportation, Department of Motor Vehicles, Motor Vehicle Commission Code [latest edition], or any other local, state and federal licenses required and which are applicable to the respondent's operations.
2. The prescribed licenses must include the manufacturer/respondent, and any and all dealers and their representatives as may be required by the Motor Vehicle Department. Contractor must ensure all

emergency and specialty vehicles sold are in accordance with the laws of the state where the sale and acquisition are made.

3. Contractor must maintain all licensing required by the State of Texas as applicable to their business operations during the entire contract term. If during the contract period such licensing lapses, Contractor will be in default and become subject to contract termination unless issued a stay or waiver.

### **Manuals**

1. Contractor must supply at the time of delivery, at least two (2) sets of complete operations and service documentation covering the completed emergency vehicles as delivered and accepted.
2. Respondent must supply the following information with their response: Technical Specifications, Product Brochures, Tear Sheets, Cut Sheets, Strippers, etc. which clearly show all the standard features and capabilities of each response listing.

### **Warranty**

Contractors must comply with the minimum warranty and maintenance requirements described below for any products or services provided under this Solicitation.

1. Contractor must furnish with response, and for all equipment sold through this H-GAC contract, the manufacturer's general warranty, which must be honored by all the manufacturer's authorized service locations.
2. All service/maintenance plan listings must clearly indicate the cost structure for such plans, clearly indicating which costs and fees are included (such as: hourly labor rates, shop fees, supply fees, environmental fees).
3. The Contractor will handle all warranty claims and all work must be completed within ten (10) calendar days after receipt of equipment/vehicle by the Contractor without cost to H-GAC or the Customer. Delayed warranties must be available for all vehicles and equipment. Warranty start date will be effective the date that the completed unit is placed into service by the Customer. The Contractor must furnish a delayed warranty card/document for each unit delivered and/or advise the Customer of the procedures to be followed for obtaining the delayed start of warranty coverage. Requests for delayed warranties will not exceed six months after delivery.
4. Any and all documents necessary to effect manufacturer's warranty must be properly applied for and submitted by the Contractor. The Contractor will provide to H-GAC and the Customer a manufacturer's warranty which will be honored by any of the manufacturer's authorized dealers and a complete copy must be provided at the time of delivery. When additional warranties are available as standard, they must be included as a part of the response for the benefit of H-GAC and Customer.
5. The patient compartment, all modifications to the OEM chassis by Contractor on the accepted unit, and equipment and parts will be guaranteed for a minimum period of one (1) year against defects in design,

materials, and workmanship. The warranty period will begin upon final acceptance of the equipment. This warranty will cover parts and labor expenses.

6. In the event any component part of equipment or materials furnished under these specifications, or its subsequent contract(s), becomes defective by reason of material or workmanship during said period, and the end user agency immediately notifies Contractor of such defect, Contractor will, at no expense to the End User agency or H-GAC, repair or replace equipment or component with new equipment or component.
7. Warranty of all system equipment is the sole responsibility of the Contractor under contract, but may be performed by their certified, designated agent.

#### 4.5. Vehicle Requirements

All equipment and vehicles must be new and be the manufacturer's latest and current model. Each vehicle must be fully assembled, adjusted, serviced and ready for immediate and continuous operation upon delivery. If the equipment or vehicle does not meet the specification requirements upon delivery, Contractor will be responsible for correcting all deficiencies and making any corrections or adjustments needed to attain specification requirements.

All equipment and vehicles must conform to applicable local, state, federal requirements and must comply to all applicable industry standards including National Fire Protection Association (NFPA), Department of Transportation, United States Coast Guard (USCG), and Occupational Safety and Health Administration (OSHA).

#### 4.6. Service / Maintenance Plans and Parts

All service/maintenance plan listings must clearly indicate the cost structure for such plans, including which costs and fees are included (ex: hourly labor rates, shop fees, supply fees, environmental fees).

#### 4.7. Labor Hours Definitions

If the awarded contract contains hours for labor related services, the following definitions will apply:

1. "Business Day" Monday through Friday
2. "Business Hours" Standard Business Hours 8 a.m. to 5 p.m.
3. "Regular Time" Work that occurs during standard business hours
4. "Emergency Time" Work that occurs outside standard business hours

#### 4.8. Administrative Fee

For each purchase order processed under an awarded contract, H-GAC will directly invoice the contractor an administrative fee (Order Processing Charge) applicable to the sale of all equipment and services submitted in contractor's response. It is the contractor's responsibility to remit the administrative fee within thirty (30) days of processing any customer's purchase order, even if an invoice is not received from H-GAC. Contractor agrees that H-GAC will have the right, with reasonable notice, to inspect its records pertaining to purchase orders processed and the accuracy of the fees payable to H-GAC. For this solicitation the administrative fee is as follows:

**Administrative Fee (per Purchase Order)**

<b>Category A</b> – Brush Trucks/Light Rescue	\$1,000 per purchase order
<b>Category B</b> – Aerial Fire Apparatus	\$2,000 per purchase order
<b>Category C</b> – Pumper Fire Apparatus	\$2,000 per purchase order
<b>Category D</b> – Pumper/Tanker and Tanker Apparatus	\$2,000 per purchase order
<b>Category E</b> – ARFF Apparatus	\$2,000 per purchase order
<b>Category F</b> – Special Service Vehicles	
Heavy Rescue*/Special Service	\$2,000 per purchase order
Light Rescue/Quick Response	\$1,000 per purchase order
All Trailers	2% of purchase order
*Heavy Rescue is vehicle with GVWR of 26,000 and above.	
<b>Category G</b> –Fire/Rescue/Emer. Response Boats	2% of purchase order
<b>Category H</b> - Fire Command Vehicles	\$1,000 per purchase order
<b>Category I</b> - Alternative Fuel Vehicles	Fee determined by category of vehicle
<b>Category J</b> –Service/Maintenance Plans	2% per purchase order
<b>Category K</b> - Fire Apparatus/Vehicle Parts and Supplies	2% per purchase order
<b>Category L</b> - Fire Apparatus/Vehicle Options	No separate fee - part of vehicle

**4.9. Final Contract Deliverables**

Contractor agrees to submit written quarterly reports to H-GAC detailing all transactions during the previous three (3) month period. Reports must include, but are not limited, to the following information:

- Customer Name and address
- HGACBuy confirmation number
- Product/Service purchased
- Customer Purchase Order Number
- Purchase Order Date
- Product/Service dollar amount
- HGACBuy Order Processing Charge amount

Reports must be provided to H-GAC in Excel or other acceptable electronic format by the 30th day of the month following the quarter being reported. If Contractor defaults in providing Products or Services reporting as required by the contract, recourse may be exercised through cancellation of the contract and other legal remedies as appropriate.

--End of section--

**Attachment A**  
**Siddons-Martin Emergency Group, LLC**  
**Fire Apparatus and Related Vehicles**  
**Contract No.: FS12-23**

Manufacturer	Product	Item Description	Offered List Price	HGACBuy Discount
		<b>Category A - Wildland and Brush</b>		
Pierce	23W-101	1019 Ford F-550 Pumper - 1019	\$ 366,288.00	5%
Pierce	23W - 103 International Type 3	International Wildland-1039	\$ 581,003.00	5%
Pierce	23W - 104 International Urban	International Urban Interface-1040	\$ 491,716.00	5%
BME Fire Trucks	Summit	Navistar, 4x4, 4-Door, Model 34, 1000 GPM Pump, 500 Gallon Water Tank	\$ 544,632.00	5%
BME Fire Trucks	Targhee	Navistar, 4x4, 4-Door, Model 34, 500 GPM Pump, 500 Gallon Water Tank	\$ 529,854.00	5%
BME Fire Trucks	Rocky Mountain	Navistar, 4x4, 4-Door, Type 3, Model 346/500R, 600 Gallon Water Tank, 500 GPM Pump	\$ 455,062.00	5%
BME Fire Trucks	Aspen	Navistar, 4x4, 4-Door, Type 4, 800 Gallon Water Tank, 1.5AGE Pump	\$ 449,583.00	5%
BME Fire Trucks	McCall	Dodge, Type 6, 300 Gallon Water Tank, 1.5AGE Pump	\$ 294,167.00	5%
BME Fire Trucks	Ponderosa	Type 6, 300 Gallon Water Tank, 1.5AGE Pump	\$ 325,057.00	5%
BME Fire Trucks	Sawtooth	Type 6, 300 Gallon Water Tank, 1.5AGE Pump	\$ 329,057.00	5%
BME Fire Trucks	Big Horn	Navistar, 4x4, 4-Door, Wildland Urban Interface, 750 Gallon Water Tank, 1000 GPM Pump	\$ 606,667.00	5%
		<b>Category B - Aerial Fire Apparatus</b>		
Pierce	23A-101	Enforcer Chassis, Single Rear Axle, 75' Aerial - 1027	\$ 1,436,022.00	5%
Pierce	23A-102	Enforcer Chassis, Tandem Rear Axle, PUC, 75' Aerial - 1028	\$ 1,474,688.00	5%
Pierce	23A-103	Velocity Chassis, Tandem Rear Axle, 100' Aerial - 1029	\$ 1,648,105.00	5%
Pierce	23A-104	Enforcer Chassis, Single Rear 107' Aerial -1030	\$ 1,589,837.00	5%
Pierce	23A-105	Enforcer Chassis, Tandem Rear Axle, 107' Aerial - 1031	\$ 1,699,833.00	5%
Pierce	23A-106	Velocity Chassis, Tandem Rear Axle, 105' Aerial - 1032	\$ 1,646,299.00	5%
Pierce	23A-107	Velocity Chassis, Tandem Rear axle, 100' Rear mounted Platform - 1033	\$ 1,912,763.00	5%
Pierce	23A-108	Velocity Chassis, Tandem Rear axle, 100' Aluminum Rear mounted Platform - 1034	\$ 2,017,959.00	5%
Pierce	23A-109	Enforcer Chassis, Tandem Rear axle, mid-mounted 100' platform - 1035	\$ 2,101,962.00	5%
Pierce	23A-110	Enforcer Chassis, 107' Tractor Drawn Aerial - 1036	\$ 2,066,551.00	5%
Pierce	23A-111	Enforcer Snozzle - 1037	\$ 1,314,701.00	5%
		<b>Category C - Pumper Fire Apparatus</b>		
Pierce	23P-102	Freightliner M2-106 Responder, 1000 Tank, 1250 Pump 1020	\$ 397,469.04	5%
Pierce	23P-103	International 4 door 1000 tank, 1250 Pump Pumper 1026	\$ 526,585.97	5%
Pierce	23P-104	Saber Pumper, 750 Tank, 1500 pump 1022	\$ 881,807.87	5%
Pierce	23P-105	Enforcer Pumper 750 tank, 1500 pump 1023	\$ 956,324.96	5%
Pierce	23P-106	Enforcer PUC Pumper 750 tank, 1500 pump 1024	\$ 1,035,341.76	5%
Pierce	23P-107	Velocity Pumper 1025	\$ 967,322.35	5%
Pierce	23P-108	Velocity PUC Pumper 1038	\$ 1,049,384.90	5%
		<b>Category D - Pumper Tanker/Tender</b>		
Pierce	23PT-101	Freightliner 2000 Gallon Tanker - 1041	\$ 511,866.00	5%
Pierce	23PT-102	International 2000 Gallon Tanker -1042	\$ 498,571.00	5%
Pierce	23PT-103	Saber 2000 Gallon Tanker - 1043	\$ 899,378.00	5%

Pierce	23PT-104	Enforcer 2000 Gallon Tanker - 1044	\$ 982,413.00	5%
Pierce	23PT-105	Freightliner 3000 Tandem Tanker - 1045	\$ 507,344.00	5%
Pierce	23PT-106	International 3000 Tandem Tanker - 1046	\$ 520,168.00	5%
Pierce	23PT-107	Saber Tandem 3000 Tanker - 1047	\$ 985,111.00	5%
Pierce	23PT-108	Enforcer Tandem 3000 Tanker - 1048	\$ 1,048,825.00	5%
Pierce	23PT-109	Velocity Tandem PUC 2500 Tanker - 1049	\$ 1,109,887.00	5%
BME Fire Trucks	Tahoe	2009 Gallon Water Tender	\$ 483,632.00	5%
BME Fire Trucks	Cascade	3000 Gallon Water Tender	\$ 552,502.00	5%
BME Fire Trucks	Clearwater	Navistar, 4x4, 4-Door, 1250 Gallon Water Tank, 500 GPM Pump Extreme Water Tender	\$ 533,552.00	5%
BME Fire Trucks	Mammoth	1250 Gallon Extreme Water Tender, Navistar 2-Door Cab	\$ 501,135.00	5%
BME Fire Trucks	Payette	1800 Gallon Tactical Water Tender	\$ 484,061.00	5%
<b>Category E - ARFF Vehicles</b>				
Oshkosh - Pierce	23AR-101	Oshkosh Striker 4x4, 2-Door, Aluminum Cab, 2 Passenger Seating, Roof Turret (375/750 gpm)	\$ 1,141,252.35	5%
Oshkosh - Pierce	23AR-102	Oshkosh Striker 6x6, 2-Door, Aluminum Cab, 2 Passenger Seating, Roof Turret (600/1200 gpm), bumper Turret (300 gpm), One Handline (Foam/Water), Water Tank Capacity (3000 gal.), Foam Tank Capacity (420 gal.), Fire Pump (Power divider driven Waterous CRQB, Single Stage Centrifugal, 1950 gpm at 250 psi)	\$ 1,217,470.80	5%
Oshkosh - Pierce	23AR-103	Oshkosh Striker 8x8, 2-Door, Aluminum Cab, 2 Passenger Seating, Roof Turret (600/1200 gpm), bumper Turret (300 gpm), One Handline (Foam/Water), Water Tank Capacity (4500 gal.), Foam Tank Capacity (420 gal.), Fire Pump (Power divider driven Waterous CRQA, Single Stage Centrifugal, 1950 gpm at 240 psi)	\$ 1,784,346.90	5%
Oshkosh - Pierce	23AR-104	Oshkosh New Generation Volterra Striker 6X6, 2-Door, Aluminum Cab, 2 Passenger Seating, Roof Turret (600/1200 gpm), bumper Turret (300 gpm), One Handline (Foam/Water), Water Tank Capacity (4500 gal.), Foam Tank Capacity (420 gal.), Fire Pump (Waterous CRQB, Single Stage Centrifugal, 1950 gpm at 250 psi), dual engine driveline	\$ 2,390,151.75	5%
Oshkosh - Pierce	23AR-HS	H-Series Chassis; 2-Door, Aluminum Cab, 2 Passenger Seating, 50,000 GVWR, Single Axle	\$ 713,119.00	5%
Oshkosh - Pierce	23AR-HTA	HT-Series Chassis; 2-Door, Aluminum Cab, 2 Passenger Seating, 55,000 GVWR, Single Axle	\$ 624,947.00	5%
<b>Category F - Special Service Vehicles/Vehicles</b>				
Pierce	23SS - 101	Ford F-550 Rescue 12' -1050	\$ 278,709.00	5%
Pierce	23SS - 102	Enforcer NWI-Rescue - 1051	\$ 975,772.00	5%
Pierce	23SS - 103	Velocity NWI-Rescue - 1052	\$ 999,751.00	5%
Pierce	23SS - 104	Enforcer PUC NWI-Rescue - 1053	\$ 1,252,488.00	5%
Pierce	23SS - 105	Velocity Combo-Rescue - 1054	\$ 1,136,418.00	5%
Pierce	23SS - 106	Enforcer Tandem Combo - 1055	\$ 1,114,686.00	5%
Pierce	23SS - 107	Velocity Alum Walk-in Rescue - 1056	\$ 1,114,461.00	5%
Pierce	23SS - 108	Enforcer Stainless NWI-Rescue - 1057	\$ 1,020,660.00	5%
Pierce	23SS - 109	Enforcer Walk-in - 1058	\$ 1,034,340.00	5%
Pierce	23SS - 110	Velocity Tandem Walk-in - 1059	\$ 1,228,431.00	5%
Frontline Communications	C-17	Mobile Command Unit, Chevrolet Suburban, 4x4, 17 feet overall length, Single axle, Gasoline	\$ 196,178.00	5%
Frontline Communications	C-20	Rapid Response Command Unit, Ford Transit-350 Van, 2WD, 20 feet overall length, Single axle, Gasoline	\$ 278,319.00	5%
Frontline Communications	CRU-22	Critical Response Command Unit, Ford Transit-350 High Roof Van, 2WD, 9,500 GVWR, 22 feet overall length, Single axle, Gasoline	\$ 353,163.00	5%
Frontline Communications	C-23	Mobile Command Unit, Mercedes-Benz Sprinter 3500, 23 feet overall length, 2WD, Single axle, Diesel	\$ 306,919.00	5%
Frontline Communications	C-25	Mobile Command Unit, Ford F-650 with custom aluminum body, 26,000 GVWR, 25 feet overall length, 2WD, Single axle, Diesel	\$ 477,451.00	5%

Frontline Communications	C-30	Mobile Command Unit, Freightliner M2-106 with custom aluminum body, 33,000 GVWR, 30 feet overall length, 2WD, Single axle, Diesel	\$ 587,098.00	5%
Frontline Communications	C-35	Mobile Command Unit, Freightliner M2-106 with custom aluminum body, 33,000 GVWR, 35 feet overall length, 2WD, Single axle, Diesel	\$ 669,849.00	5%
Frontline Communications	C-40	Mobile Command Unit, Freightliner M2-106 with custom aluminum body, 54,000 GVWR, 40 feet 9 inches overall length, 2WD, Dual axle, Diesel	\$ 735,953.00	5%
Frontline Communications	C-40 Enforcer	Mobile Command Unit, Pierce Enforcer custom chassis with custom aluminum body, 40 feet 9 inches overall length, 2WD, Dual axle, Diesel	\$ 1,546,944.00	5%
Frontline Communications	C-40 Saber	Mobile Command Unit, Pierce Saber custom chassis with custom aluminum body, 40 feet 9 inches overall length, 2WD, Dual axle, Diesel	\$ 1,017,416.00	5%
Frontline Communications	C-40 Velocity	Mobile Command Unit, Pierce Velocity custom chassis with custom aluminum body, 40 feet 9 inches overall length, 2WD, Dual axle, Diesel	\$ 1,259,403.00	5%
Frontline Communications	C-28T	Mobile Command Trailer - Custom aluminum body, 28 feet overall length, Dual axle	\$ 308,961.00	5%
Frontline Communications	C-35T	Mobile Command Trailer - Custom aluminum "gooseneck" body, 35 feet overall length, Dual axle	\$ 394,976.00	5%
Frontline Communications	C-53T	Mobile Command Trailer - Custom aluminum body, 53 feet overall length, Dual axle	\$ 1,241,546.00	5%
Frontline Communications	C-RTR	Refurb/Technology Refresh Command Vehicle - Customer-furnished vehicle, refurbish interior and/or exterior, upgrade technology	\$ 292,975.00	5%
BME Fire Trucks	Sequoia	10 Man Crew Carrier Vehicle	\$ 378,634.00	5%
		<b>Category G - Fire/Rescue Boats</b>		
Lake Assault Boats	23LAB - 101	LAB 21' Landing Craft, 8.5' beam, T-top, Emergency light bar, siren, 12" Sonar GPS Chartplotter, Scene lights, Trailer.	\$ 215,210.34	5%
Lake Assault Boats	23LAB - 102	LAB 22' RHIB, 8.5' beam, T-top, emergency light bar, 10" sonar GPS chartplotter, Trailer	\$ 200,093.94	5%
Lake Assault Boats	23LAB - 103	LAB 24' V-hull, 8.5' beam, T-top, emergency light bar, siren, 12" sonar GPS chartplotter, scene lights, Trailer	\$ 220,506.78	5%
Lake Assault Boats	23LAB - 104	LAB 24' Landing Craft, 8.5' beam, T-top, emergency light bar, siren, 12" sonar GPS chartplotter, scene lights, Trailer.	\$ 229,419.30	5%
Lake Assault Boats	23LAB - 105	LAB 26' V-hull, 9.5' beam, T-top, emergency light bar, siren, 12" sonar GPS chartplotter, scene lights, Trailer.	\$ 243,629.40	5%
Lake Assault Boats	23LAB - 106	LAB 26' Landing Craft, 9.5' beam, T-top, emergency light bar, siren, 12" sonar GPS chartplotter, scene lights, Trailer	\$ 248,141.52	5%
Lake Assault Boats	23LAB - 107	LAB 28' V-hull, 9.5' beam, walk-a-round pilot house, emergency light bar, siren, 12" sonar GPS chartplotter, scene lights, Trailer.	\$ 287,850.00	5%
Lake Assault Boats	23LAB - 108	LAB 28' Landing Craft, 9.5' beam, walk-a-round pilot house, emergency light bar, siren, 12" sonar GPS chartplotter, scene lights, Trailer.	\$ 288,978.60	5%
Lake Assault Boats	23LAB - 109	LAB 32' V-hull, 10.5' beam, walk-a-round pilot house, emergency light bar, siren, 12" sonar GPS chartplotter, scene lights, Trailer.	\$ 317,508.24	5%
Lake Assault Boats	23LAB - 110	LAB 32' Landing Craft, 10.5' beam, walk-a-round pilot house, emergency light bar, siren, 12" sonar GPS chartplotter, scene lights, Trailer.	\$ 319,320.84	5%
Lake Assault Boats	23LAB - 111	LAB 36' V-hull, 10.5' beam, full-width pilot house, emergency light bar, siren, 12" sonar GPS chartplotter, scene lights, Trailer.	\$ 345,141.84	5%
Lake Assault Boats	23LAB - 112	LAB 36' Landing Craft, 10.5' beam, full-width pilot house, emergency light bar, siren, 12" sonar GPS chartplotter, scene lights, Trailer.	\$ 347,739.90	5%
		<b>Category H - Command Vehicles</b>		
Chevrolet (Sterling McCall)	1500 PU	2023 Chevrolet Silverado 1500 2WD Crew Cab Custom/Work Truck Short Bed	\$ 53,613.00	5%
Chevrolet (Sterling McCall)	2500PU	2023 Chevrolet Silverado 2500 2WD Crew Cab Custom/Work Truck Short Bed	\$ 56,975.00	5%
Chevrolet (Sterling McCall)	Tahoe PPV	2023 Chevrolet Tahoe 2WD 5.3L V8	\$ 57,680.00	5%
Chevrolet (Freedom)	Tahoe	Chevrolet Tahoe, 4X2	\$ 57,540.00	5%
Chevrolet (Freedom)	Tahoe	PPV Tahoe, standard colors, 4X2	\$ 58,065.00	5%
Chevrolet (Freedom)	Tahoe	PPV Tahoe, standard colors, 4X4	\$ 63,000.00	5%
Chevrolet (Freedom)	Tahoe	SSV Tahoe, standard colors, 4X2	\$ 56,700.00	5%
Chevrolet (Freedom)	Pick-up	SSV Tahoe, standard colors, 4X4	\$ 61,950.00	5%
Chevrolet (Freedom)	Pick-up	1500 Crew Cab, standard colors, 4X2	\$ 51,135.00	5%
Chevrolet (Freedom)	Pick-up	1500 Crew Cab, standard colors, 4X4	\$ 56,700.00	5%
Chevrolet (Freedom)	Pick-up	2500 Crew Cab, standard colors, 4X2	\$ 58,065.00	5%
Chevrolet (Freedom)	Pick-up	2500 Crew Cab, standard colors, 4X4	\$ 63,000.00	5%
Chevrolet (Freedom)	Pick-up	2500 Crew Cab, standard colors, 4X4, Diesel	\$ 82,845.00	5%
Chevrolet (Freedom)	Pick-up	5500 Regular cab, standard colors, 4X2, Amb Prep	\$ 83,580.00	5%
Chevrolet (Freedom)	Suburban	Chevrolet Suburban 4X2	\$ 61,635.00	5%
Dodge (Freedom)	Passenger	Dodge Charger Pursuit V8, 4X2	\$ 40,845.00	5%
Dodge (Freedom)	Passenger	Dodge Charger Pursuit V6, AWD	\$ 41,685.00	5%
Dodge (Freedom)	SUV	Dodge Pursuit Durango V6 AWD	\$ 48,300.00	5%

Dodge (Freedom)	SUV	Dodge Pursuit Durango V8 AWD	\$ 51,135.00	5%
Ford (Freedom)	SUV	Ford Explorer Police Pkg, AWD	\$ 48,615.00	5%
Ford (Freedom)	SUV	Ford Explorer Police Pkg, AWD, Ecoboost	\$ 52,815.00	5%
Ford (Freedom)	SUV	Ford Expedition, 4X2	\$ 61,845.00	5%
Ford (Freedom)	SUV	Ford Expedition, 4X4	\$ 66,150.00	5%
Ford (Freedom)	SUV	Ford Expedition, 4X2, SSV	\$ 59,850.00	5%
Ford (Freedom)	SUV	Ford Expedition, 4X4, SSV	\$ 61,110.00	5%
Ford (Freedom)	SUV	Ford Expedition Max 4X2	\$ 62,685.00	5%
Ford (Freedom)	SUV	Ford Expedition Max 4X4	\$ 65,835.00	5%
<b>Category J - Service/Maintenance Plans</b>				
Oshkosh	ARFF Warranty	Multiple plans available by model - see Siddons-Martin Warranty/Service Table		
Frontline Communications	Vehicle Warranty	Multiple plans available by model - see Siddons-Martin Warranty/Service Table		
BME	Vehicle Warranty	Multiple plans available by model - see Siddons-Martin Warranty/Service Table		
Pierce Manufacturing	Vehicle Warranty	Multiple plans available by model - see Siddons-Martin Warranty/Service Table		

**Certificate Of Completion**

Envelope Id: 26841DC52E0E4C2CA6188AB99F7D6207

Status: Sent

Subject: Cooperative Agreement - Contract - Siddons Martin Emergency Group LLC - Public Services - ID: 11564

Source Envelope:

Document Pages: 32

Signatures: 1

Envelope Originator:

Certificate Pages: 1

Initials: 0

Houston-Galveston Area Council

AutoNav: Enabled

3555 Timmons Lane, Suite 120

Envelope Stamping: Enabled

Houston, TX 77027

Time Zone: (UTC-06:00) Central Time (US & Canada)

contracts@h-gac.com

IP Address: 12.11.127.21

**Record Tracking**

Status: Original

Holder: Houston-Galveston Area Council

Location: DocuSign

12/11/2023 10:01:18 AM

contracts@h-gac.com

**Signer Events**

Jeff Doran

jdoran@siddons-martin.com

Director - Order Mngement

Security Level: Email, Account Authentication (None)

**Signature**

DocuSigned by:  
  
 B20885F885D14E7...

**Timestamp**

Sent: 12/11/2023 10:06:00 AM

Viewed: 12/11/2023 10:32:47 AM

Signed: 12/11/2023 10:32:59 AM

Signature Adoption: Pre-selected Style

Using IP Address: 12.190.209.19

**Electronic Record and Signature Disclosure:**

Not Offered via DocuSign

Charles Wemple

charles.wemple@h-gac.com

Executive Director

Houston-Galveston Area Council

Security Level: Email, Account Authentication (None)

Sent: 12/11/2023 10:33:01 AM

**Electronic Record and Signature Disclosure:**

Not Offered via DocuSign

**In Person Signer Events**

Signature

Timestamp

**Editor Delivery Events**

Status

Timestamp

**Agent Delivery Events**

Status

Timestamp

**Intermediary Delivery Events**

Status

Timestamp

**Certified Delivery Events**

Status

Timestamp

**Carbon Copy Events**

Status

Timestamp

**Witness Events**

Signature

Timestamp

**Notary Events**

Signature

Timestamp

**Envelope Summary Events**

Status

Timestamps

Envelope Sent

Hashed/Encrypted

12/11/2023 10:06:00 AM

**Payment Events**

Status

Timestamps



**CONTRACT PRICING WORKSHEET**  
For MOTOR VEHICLES Only

Contract No.: FS12-23

Date Prepared: 8/19/2024

Due to global supply chain constraints, any delivery date contained herein is a good faith estimate as of the date of this order/contract. As needed, delivery updates will be provided as soon as possible.

Buying Agency:	City of Santa Fe	Contractor:	Siddons-Martin Emergency Group
Contact Person:	Daniel Garcia	Prepared By:	Jeffrey Doran
Phone:	505-231-8561	Phone:	1-800-784-6806
Fax:		Fax:	
Email:	dagarcia@santafenm.gov	Email:	doran@siddons-martin.com
Product Description:	Targhee May 2024 Pricing		Targhee Type 34

**A. Product Item Base Unit Price Per Contractor's H-GAC Contract:** \$503,361.00

**B. Published Options - Itemize below - Attach additional sheet(s) if necessary.**  
(Note: Published Options are "manufacturer standard options" which were submitted and priced in Contractor's proposal.)

Description	Cost	Description	Cost
Subtotal From Additional Sheet(s):			
Subtotal B:			\$0.00

**C. Customization Category Totals - Itemize below / Attach additional sheet(s) if necessary.**  
(Note: Customization options are "manufacturer non-standard options" which were submitted and priced in Contractor's proposal.)

Description	Cost	Description	Cost
Subtotal From Additional Sheet(s):			
Subtotal C:			\$0.00

**Check:** Total cost of Customization Categories (C) cannot exceed 25% of the total of the Base Unit Price plus Published Options (A+B). For this transaction the percentage is: 0%

**D. Total Cost Before Any Applicable Trade-In / Other Allowances / Discounts (A+B+C)**

Quantity Ordered:	1	X Subtotal of A + B + C:	503,361	=	Subtotal D:	\$503,361.00
-------------------	---	--------------------------	---------	---	-------------	--------------

**E. H-GAC Order Processing Charge (Amount Per Current Policy)** Subtotal E: \$2,000.00

**F. Trade-Ins / Special Discounts / Other Allowances / Freight / Installation / Miscellaneous Charges**

Description	Cost	Description	Cost
		Stock unit 3892 Discount	-\$19,011.00
Subtotal F:			-\$19,011.00

**Delivery Date:** 30-90 days ARO **G. Total Purchase Price (D+E+F):** \$486,350.00





# CITY OF ALBUQUERQUE BUSINESS REGISTRATION

CITY OF ALBUQUERQUE  
P.O. BOX 1293  
ALBUQUERQUE, NM 87102

SIDDONS MARTIN EMERGENCY GROUP LLC  
1362 EAST RICHEY ROAD  
HOUSTON TX 77073

---

## CITY OF ALBUQUERQUE

SIDDONS MARTIN EMERGENCY GROUP LLC  
4214 2ND ST NW  
ALBUQUERQUE NM

PERMIT NO: COM-2017-343661

PROGRAM: BUSINESS REGISTRATION

EFFECTIVE FROM: 03/06/2024 THROUGH: 03/05/2025

---

HAVING COMPLIED WITH THE FEE REQUIREMENTS OF CHAPTER 13 ARTICLE 1 OF THE REVISED ORDINANCES.

REGISTRATION OR LICENSING WITH THE CITY OF ALBUQUERQUE AND PAYMENT OF FEES DOES NOT CONSTITUTE A  
WAIVER OF ANY REQUIREMENTS OR PROVISIONS CONTAINED AT ANY LAW.

THE ACTIVITY/BUSINESS PROPOSED TO BE CONDUCTED AT ANY LOCATION WITHIN THE CITY SHALL BE APPROVED BY  
THE CITY'S ZONING ENFORCEMENT OFFICER PRIOR TO COMMENCING THE ACTIVITY/BUSINESS.

PLANNING DEPARTMENT - CODE ENFORCEMENT DIVISION

[WWW.BIZTEG.CABQ.GOV](http://WWW.BIZTEG.CABQ.GOV)

(505) 924-3890

POST IN A CONSPICUOUS PLACE.

# Request for Taxpayer Identification Number and Certification

Go to [www.irs.gov/FormW9](http://www.irs.gov/FormW9) for instructions and the latest information.

**Give form to the  
 requester. Do not  
 send to the IRS.**

**Before you begin.** For guidance related to the purpose of Form W-9, see *Purpose of Form*, below.

<b>Print or type. See Specific Instructions on page 3.</b>	<p><b>1</b> Name of entity/individual. An entry is required. (For a sole proprietor or disregarded entity, enter the owner's name on line 1, and enter the business/disregarded entity's name on line 2.)</p> <p><b>Siddons Martin Emergency Group, LLC</b></p>	
	<p><b>2</b> Business name/disregarded entity name, if different from above.</p>	
	<p><b>3a</b> Check the appropriate box for federal tax classification of the entity/individual whose name is entered on line 1. Check only <b>one</b> of the following seven boxes.</p> <p><input type="checkbox"/> Individual/sole proprietor    <input type="checkbox"/> C corporation    <input type="checkbox"/> S corporation    <input type="checkbox"/> Partnership    <input type="checkbox"/> Trust/estate</p> <p><input checked="" type="checkbox"/> <b>LLC.</b> Enter the tax classification (C = C corporation, S = S corporation, P = Partnership) . . . . . <b>S</b></p> <p><small>Note: Check the "LLC" box above and, in the entry space, enter the appropriate code (C, S, or P) for the tax classification of the LLC, unless it is a disregarded entity. A disregarded entity should instead check the appropriate box for the tax classification of its owner.</small></p> <p><input type="checkbox"/> Other (see instructions)</p>	<p><b>4</b> Exemptions (codes apply only to certain entities, not individuals; see instructions on page 3):</p> <p>Exempt payee code (if any) _____</p> <p>Exemption from Foreign Account Tax Compliance Act (FATCA) reporting code (if any) _____</p> <p style="text-align: right;"><i>(Applies to accounts maintained outside the United States.)</i></p>
	<p><b>3b</b> If on line 3a you checked "Partnership" or "Trust/estate," or checked "LLC" and entered "P" as its tax classification, and you are providing this form to a partnership, trust, or estate in which you have an ownership interest, check this box if you have any foreign partners, owners, or beneficiaries. See instructions . . . . . <input type="checkbox"/></p>	
	<p><b>5</b> Address (number, street, and apt. or suite no.). See instructions.</p> <p><b>1362 E Richey Road</b></p>	<p>Requester's name and address (optional)</p>
	<p><b>6</b> City, state, and ZIP code</p> <p><b>Houston, Texas 77073</b></p>	
	<p><b>7</b> List account number(s) here (optional)</p>	

**Part I Taxpayer Identification Number (TIN)**

Enter your TIN in the appropriate box. The TIN provided must match the name given on line 1 to avoid backup withholding. For individuals, this is generally your social security number (SSN). However, for a resident alien, sole proprietor, or disregarded entity, see the instructions for Part I, later. For other entities, it is your employer identification number (EIN). If you do not have a number, see *How to get a TIN*, later.

**Note:** If the account is in more than one name, see the instructions for line 1. See also *What Name and Number To Give the Requester* for guidelines on whose number to enter.

<b>Social security number</b>									
<b>or</b>									
<b>Employer identification number</b>									
2	7	-	4	3	3	3	5	9	0

**Part II Certification**

Under penalties of perjury, I certify that:

- The number shown on this form is my correct taxpayer identification number (or I am waiting for a number to be issued to me); and
- I am not subject to backup withholding because (a) I am exempt from backup withholding, or (b) I have not been notified by the Internal Revenue Service (IRS) that I am subject to backup withholding as a result of a failure to report all interest or dividends, or (c) the IRS has notified me that I am no longer subject to backup withholding; and
- I am a U.S. citizen or other U.S. person (defined below); and
- The FATCA code(s) entered on this form (if any) indicating that I am exempt from FATCA reporting is correct.

**Certification instructions.** You must cross out item 2 above if you have been notified by the IRS that you are currently subject to backup withholding because you have failed to report all interest and dividends on your tax return. For real estate transactions, item 2 does not apply. For mortgage interest paid, acquisition or abandonment of secured property, cancellation of debt, contributions to an individual retirement arrangement (IRA), and, generally, payments other than interest and dividends, you are not required to sign the certification, but you must provide your correct TIN. See the instructions for Part II, later.

<b>Sign Here</b>	Signature of U.S. person 	Date <b>3/15/2024</b>
------------------	------------------------------	--------------------------

## General Instructions

Section references are to the Internal Revenue Code unless otherwise noted.

**Future developments.** For the latest information about developments related to Form W-9 and its instructions, such as legislation enacted after they were published, go to [www.irs.gov/FormW9](http://www.irs.gov/FormW9).

### What's New

Line 3a has been modified to clarify how a disregarded entity completes this line. An LLC that is a disregarded entity should check the appropriate box for the tax classification of its owner. Otherwise, it should check the "LLC" box and enter its appropriate tax classification.

New line 3b has been added to this form. A flow-through entity is required to complete this line to indicate that it has direct or indirect foreign partners, owners, or beneficiaries when it provides the Form W-9 to another flow-through entity in which it has an ownership interest. This change is intended to provide a flow-through entity with information regarding the status of its indirect foreign partners, owners, or beneficiaries, so that it can satisfy any applicable reporting requirements. For example, a partnership that has any indirect foreign partners may be required to complete Schedules K-2 and K-3. See the Partnership Instructions for Schedules K-2 and K-3 (Form 1065).

### Purpose of Form

An individual or entity (Form W-9 requester) who is required to file an information return with the IRS is giving you this form because they



must obtain your correct taxpayer identification number (TIN), which may be your social security number (SSN), individual taxpayer identification number (ITIN), adoption taxpayer identification number (ATIN), or employer identification number (EIN), to report on an information return the amount paid to you, or other amount reportable on an information return. Examples of information returns include, but are not limited to, the following.

- Form 1099-INT (Interest earned or paid).
- Form 1099-DIV (dividends, including those from stocks or mutual funds).
- Form 1099-MISC (various types of income, prizes, awards, or gross proceeds).
- Form 1099-NEC (nonemployee compensation).
- Form 1099-B (stock or mutual fund sales and certain other transactions by brokers).
- Form 1099-S (proceeds from real estate transactions).
- Form 1099-K (merchant card and third-party network transactions).
- Form 1098 (home mortgage interest), 1098-E (student loan interest), and 1098-T (tuition).
- Form 1099-C (canceled debt).
- Form 1099-A (acquisition or abandonment of secured property).

Use Form W-9 only if you are a U.S. person (including a resident alien), to provide your correct TIN.

**Caution:** If you don't return Form W-9 to the requester with a TIN, you might be subject to backup withholding. See *What is backup withholding*, later.

**By signing the filled-out form, you:**

1. Certify that the TIN you are giving is correct (or you are waiting for a number to be issued);
2. Certify that you are not subject to backup withholding; or
3. Claim exemption from backup withholding if you are a U.S. exempt payee; and
4. Certify to your non-foreign status for purposes of withholding under chapter 3 or 4 of the Code (if applicable); and
5. Certify that FATCA code(s) entered on this form (if any) indicating that you are exempt from the FATCA reporting is correct. See *What is FATCA Reporting*, later, for further information.

**Note:** If you are a U.S. person and a requester gives you a form other than Form W-9 to request your TIN, you must use the requester's form if it is substantially similar to this Form W-9.

**Definition of a U.S. person.** For federal tax purposes, you are considered a U.S. person if you are:

- An individual who is a U.S. citizen or U.S. resident alien;
- A partnership, corporation, company, or association created or organized in the United States or under the laws of the United States;
- An estate (other than a foreign estate); or
- A domestic trust (as defined in Regulations section 301.7701-7).

**Establishing U.S. status for purposes of chapter 3 and chapter 4 withholding.** Payments made to foreign persons, including certain distributions, allocations of income, or transfers of sales proceeds, may be subject to withholding under chapter 3 or chapter 4 of the Code (sections 1441-1474). Under those rules, if a Form W-9 or other certification of non-foreign status has not been received, a withholding agent, transferee, or partnership (payor) generally applies presumption rules that may require the payor to withhold applicable tax from the recipient, owner, transferor, or partner (payee). See Pub. 515, *Withholding of Tax on Nonresident Aliens and Foreign Entities*.

The following persons must provide Form W-9 to the payor for purposes of establishing its non-foreign status.

- In the case of a disregarded entity with a U.S. owner, the U.S. owner of the disregarded entity and not the disregarded entity.
- In the case of a grantor trust with a U.S. grantor or other U.S. owner, generally, the U.S. grantor or other U.S. owner of the grantor trust and not the grantor trust.
- In the case of a U.S. trust (other than a grantor trust), the U.S. trust and not the beneficiaries of the trust.

See Pub. 515 for more information on providing a Form W-9 or a certification of non-foreign status to avoid withholding.

**Foreign person.** If you are a foreign person or the U.S. branch of a foreign bank that has elected to be treated as a U.S. person (under Regulations section 1.1441-1(b)(2)(iv) or other applicable section for chapter 3 or 4 purposes), do not use Form W-9. Instead, use the appropriate Form W-8 or Form 8233 (see Pub. 515). If you are a qualified foreign pension fund under Regulations section 1.897(f)-1(d), or a partnership that is wholly owned by qualified foreign pension funds, that is treated as a non-foreign person for purposes of section 1445 withholding, do not use Form W-9. Instead, use Form W-8EXP (or other certification of non-foreign status).

**Nonresident alien who becomes a resident alien.** Generally, only a nonresident alien individual may use the terms of a tax treaty to reduce or eliminate U.S. tax on certain types of income. However, most tax treaties contain a provision known as a saving clause. Exceptions specified in the saving clause may permit an exemption from tax to continue for certain types of income even after the payee has otherwise become a U.S. resident alien for tax purposes.

If you are a U.S. resident alien who is relying on an exception contained in the saving clause of a tax treaty to claim an exemption from U.S. tax on certain types of income, you must attach a statement to Form W-9 that specifies the following five items.

1. The treaty country. Generally, this must be the same treaty under which you claimed exemption from tax as a nonresident alien.
2. The treaty article addressing the income.
3. The article number (or location) in the tax treaty that contains the saving clause and its exceptions.
4. The type and amount of income that qualifies for the exemption from tax.
5. Sufficient facts to justify the exemption from tax under the terms of the treaty article.

**Example.** Article 20 of the U.S.-China income tax treaty allows an exemption from tax for scholarship income received by a Chinese student temporarily present in the United States. Under U.S. law, this student will become a resident alien for tax purposes if their stay in the United States exceeds 5 calendar years. However, paragraph 2 of the first Protocol to the U.S.-China treaty (dated April 30, 1984) allows the provisions of Article 20 to continue to apply even after the Chinese student becomes a resident alien of the United States. A Chinese student who qualifies for this exception (under paragraph 2 of the first Protocol) and is relying on this exception to claim an exemption from tax on their scholarship or fellowship income would attach to Form W-9 a statement that includes the information described above to support that exemption.

If you are a nonresident alien or a foreign entity, give the requester the appropriate completed Form W-8 or Form 8233.

## Backup Withholding

**What is backup withholding?** Persons making certain payments to you must under certain conditions withhold and pay to the IRS 24% of such payments. This is called "backup withholding." Payments that may be subject to backup withholding include, but are not limited to, interest, tax-exempt interest, dividends, broker and barter exchange transactions, rents, royalties, nonemployee pay, payments made in settlement of payment card and third-party network transactions, and certain payments from fishing boat operators. Real estate transactions are not subject to backup withholding.

You will not be subject to backup withholding on payments you receive if you give the requester your correct TIN, make the proper certifications, and report all your taxable interest and dividends on your tax return.

**Payments you receive will be subject to backup withholding if:**

1. You do not furnish your TIN to the requester;
2. You do not certify your TIN when required (see the instructions for Part II for details);
3. The IRS tells the requester that you furnished an incorrect TIN;
4. The IRS tells you that you are subject to backup withholding because you did not report all your interest and dividends on your tax return (for reportable interest and dividends only); or
5. You do not certify to the requester that you are not subject to backup withholding, as described in item 4 under "*By signing the filled-out form*" above (for reportable interest and dividend accounts opened after 1983 only).

Certain payees and payments are exempt from backup withholding. See *Exempt payee code*, later, and the separate instructions for the Requester of Form W-9 for more information.

See also *Establishing U.S. status for purposes of chapter 3 and chapter 4 withholding*, earlier.

## What Is FATCA Reporting?

The Foreign Account Tax Compliance Act (FATCA) requires a participating foreign financial institution to report all U.S. account holders that are specified U.S. persons. Certain payees are exempt from FATCA reporting. See *Exemption from FATCA reporting code*, later, and the Instructions for the Requester of Form W-9 for more information.

## Updating Your Information

You must provide updated information to any person to whom you claimed to be an exempt payee if you are no longer an exempt payee and anticipate receiving reportable payments in the future from this person. For example, you may need to provide updated information if you are a C corporation that elects to be an S corporation, or if you are no longer tax exempt. In addition, you must furnish a new Form W-9 if the name or TIN changes for the account, for example, if the grantor of a grantor trust dies.

## Penalties

**Failure to furnish TIN.** If you fail to furnish your correct TIN to a requester, you are subject to a penalty of \$50 for each such failure unless your failure is due to reasonable cause and not to willful neglect.

**Civil penalty for false information with respect to withholding.** If you make a false statement with no reasonable basis that results in no backup withholding, you are subject to a \$500 penalty.

**Criminal penalty for falsifying information.** Willfully falsifying certifications or affirmations may subject you to criminal penalties including fines and/or imprisonment.

**Misuse of TINs.** If the requester discloses or uses TINs in violation of federal law, the requester may be subject to civil and criminal penalties.

## Specific Instructions

### Line 1

You must enter one of the following on this line; do not leave this line blank. The name should match the name on your tax return.

If this Form W-9 is for a joint account (other than an account maintained by a foreign financial institution (FFI)), list first, and then circle, the name of the person or entity whose number you entered in Part I of Form W-9. If you are providing Form W-9 to an FFI to document a joint account, each holder of the account that is a U.S. person must provide a Form W-9.

- **Individual.** Generally, enter the name shown on your tax return. If you have changed your last name without informing the Social Security Administration (SSA) of the name change, enter your first name, the last name as shown on your social security card, and your new last name.

**Note for ITIN applicant:** Enter your individual name as it was entered on your Form W-7 application, line 1a. This should also be the same as the name you entered on the Form 1040 you filed with your application.

- **Sole proprietor.** Enter your individual name as shown on your Form 1040 on line 1. Enter your business, trade, or "doing business as" (DBA) name on line 2.

- **Partnership, C corporation, S corporation, or LLC, other than a disregarded entity.** Enter the entity's name as shown on the entity's tax return on line 1 and any business, trade, or DBA name on line 2.

- **Other entities.** Enter your name as shown on required U.S. federal tax documents on line 1. This name should match the name shown on the charter or other legal document creating the entity. Enter any business, trade, or DBA name on line 2.

- **Disregarded entity.** In general, a business entity that has a single owner, including an LLC, and is not a corporation, is disregarded as an entity separate from its owner (a disregarded entity). See Regulations section 301.7701-2(c)(2). A disregarded entity should check the appropriate box for the tax classification of its owner. Enter the owner's name on line 1. The name of the owner entered on line 1 should never be a disregarded entity. The name on line 1 should be the name shown on the income tax return on which the income should be reported. For

example, if a foreign LLC that is treated as a disregarded entity for U.S. federal tax purposes has a single owner that is a U.S. person, the U.S. owner's name is required to be provided on line 1. If the direct owner of the entity is also a disregarded entity, enter the first owner that is not disregarded for federal tax purposes. Enter the disregarded entity's name on line 2. If the owner of the disregarded entity is a foreign person, the owner must complete an appropriate Form W-8 instead of a Form W-9. This is the case even if the foreign person has a U.S. TIN.

### Line 2

If you have a business name, trade name, DBA name, or disregarded entity name, enter it on line 2.

### Line 3a

Check the appropriate box on line 3a for the U.S. federal tax classification of the person whose name is entered on line 1. Check only one box on line 3a.

IF the entity/individual on line 1 is a(n) . . .	THEN check the box for . . .
• Corporation	Corporation.
• Individual or • Sole proprietorship	Individual/sole proprietor.
• LLC classified as a partnership for U.S. federal tax purposes or • LLC that has filed Form 8832 or 2553 electing to be taxed as a corporation	Limited liability company and enter the appropriate tax classification: P = Partnership, C = C corporation, or S = S corporation.
• Partnership	Partnership.
• Trust/estate	Trust/estate.

### Line 3b

Check this box if you are a partnership (including an LLC classified as a partnership for U.S. federal tax purposes), trust, or estate that has any foreign partners, owners, or beneficiaries, and you are providing this form to a partnership, trust, or estate, in which you have an ownership interest. You must check the box on line 3b if you receive a Form W-8 (or documentary evidence) from any partner, owner, or beneficiary establishing foreign status or if you receive a Form W-9 from any partner, owner, or beneficiary that has checked the box on line 3b.

**Note:** A partnership that provides a Form W-9 and checks box 3b may be required to complete Schedules K-2 and K-3 (Form 1065). For more information, see the Partnership Instructions for Schedules K-2 and K-3 (Form 1065).

If you are required to complete line 3b but fail to do so, you may not receive the information necessary to file a correct information return with the IRS or furnish a correct payee statement to your partners or beneficiaries. See, for example, sections 6698, 6722, and 6724 for penalties that may apply.

### Line 4 Exemptions

If you are exempt from backup withholding and/or FATCA reporting, enter in the appropriate space on line 4 any code(s) that may apply to you.

#### Exempt payee code.

- Generally, individuals (including sole proprietors) are not exempt from backup withholding.
- Except as provided below, corporations are exempt from backup withholding for certain payments, including interest and dividends.
- Corporations are not exempt from backup withholding for payments made in settlement of payment card or third-party network transactions.
- Corporations are not exempt from backup withholding with respect to attorneys' fees or gross proceeds paid to attorneys, and corporations that provide medical or health care services are not exempt with respect to payments reportable on Form 1099-MISC.

The following codes identify payees that are exempt from backup withholding. Enter the appropriate code in the space on line 4.

1—An organization exempt from tax under section 501(a), any IRA, or a custodial account under section 403(b)(7) if the account satisfies the requirements of section 401(f)(2).

- 2—The United States or any of its agencies or instrumentalities.
- 3—A state, the District of Columbia, a U.S. commonwealth or territory, or any of their political subdivisions or instrumentalities.
- 4—A foreign government or any of its political subdivisions, agencies, or instrumentalities.
- 5—A corporation.
- 6—A dealer in securities or commodities required to register in the United States, the District of Columbia, or a U.S. commonwealth or territory.
- 7—A futures commission merchant registered with the Commodity Futures Trading Commission.
- 8—A real estate investment trust.
- 9—An entity registered at all times during the tax year under the Investment Company Act of 1940.
- 10—A common trust fund operated by a bank under section 584(a).
- 11—A financial institution as defined under section 581.
- 12—A middleman known in the investment community as a nominee or custodian.
- 13—A trust exempt from tax under section 664 or described in section 4947.

The following chart shows types of payments that may be exempt from backup withholding. The chart applies to the exempt payees listed above, 1 through 13.

IF the payment is for . . .	THEN the payment is exempt for . . .
• Interest and dividend payments	All exempt payees except for 7.
• Broker transactions	Exempt payees 1 through 4 and 6 through 11 and all C corporations. S corporations must not enter an exempt payee code because they are exempt only for sales of noncovered securities acquired prior to 2012.
• Barter exchange transactions and patronage dividends	Exempt payees 1 through 4.
• Payments over \$600 required to be reported and direct sales over \$5,000 <sup>1</sup>	Generally, exempt payees 1 through 5. <sup>2</sup>
• Payments made in settlement of payment card or third-party network transactions	Exempt payees 1 through 4.

<sup>1</sup> See Form 1099-MISC, Miscellaneous Information, and its instructions.

<sup>2</sup> However, the following payments made to a corporation and reportable on Form 1099-MISC are not exempt from backup withholding: medical and health care payments, attorneys' fees, gross proceeds paid to an attorney reportable under section 6045(f), and payments for services paid by a federal executive agency.

**Exemption from FATCA reporting code.** The following codes identify payees that are exempt from reporting under FATCA. These codes apply to persons submitting this form for accounts maintained outside of the United States by certain foreign financial institutions. Therefore, if you are only submitting this form for an account you hold in the United States, you may leave this field blank. Consult with the person requesting this form if you are uncertain if the financial institution is subject to these requirements. A requester may indicate that a code is not required by providing you with a Form W-9 with "Not Applicable" (or any similar indication) entered on the line for a FATCA exemption code.

- A—An organization exempt from tax under section 501(a) or any individual retirement plan as defined in section 7701(a)(37).
- B—The United States or any of its agencies or instrumentalities.
- C—A state, the District of Columbia, a U.S. commonwealth or territory, or any of their political subdivisions or instrumentalities.
- D—A corporation the stock of which is regularly traded on one or more established securities markets, as described in Regulations section 1.1472-1(c)(1)(i).
- E—A corporation that is a member of the same expanded affiliated group as a corporation described in Regulations section 1.1472-1(c)(1)(i).

- F—A dealer in securities, commodities, or derivative financial instruments (including notional principal contracts, futures, forwards, and options) that is registered as such under the laws of the United States or any state.
- G—A real estate investment trust.
- H—A regulated investment company as defined in section 851 or an entity registered at all times during the tax year under the Investment Company Act of 1940.
- I—A common trust fund as defined in section 584(a).
- J—A bank as defined in section 581.
- K—A broker.
- L—A trust exempt from tax under section 664 or described in section 4947(a)(1).
- M—A tax-exempt trust under a section 403(b) plan or section 457(g) plan.

**Note:** You may wish to consult with the financial institution requesting this form to determine whether the FATCA code and/or exempt payee code should be completed.

**Line 5**

Enter your address (number, street, and apartment or suite number). This is where the requester of this Form W-9 will mail your information returns. If this address differs from the one the requester already has on file, enter "NEW" at the top. If a new address is provided, there is still a chance the old address will be used until the payor changes your address in their records.

**Line 6**

Enter your city, state, and ZIP code.

**Part I. Taxpayer Identification Number (TIN)**

**Enter your TIN in the appropriate box.** If you are a resident alien and you do not have, and are not eligible to get, an SSN, your TIN is your IRS ITIN. Enter it in the entry space for the Social Security number. If you do not have an ITIN, see *How to get a TIN* below.

If you are a sole proprietor and you have an EIN, you may enter either your SSN or EIN.

If you are a single-member LLC that is disregarded as an entity separate from its owner, enter the owner's SSN (or EIN, if the owner has one). If the LLC is classified as a corporation or partnership, enter the entity's EIN.

**Note:** See *What Name and Number To Give the Requester*, later, for further clarification of name and TIN combinations.

**How to get a TIN.** If you do not have a TIN, apply for one immediately. To apply for an SSN, get Form SS-5, Application for a Social Security Card, from your local SSA office or get this form online at [www.SSA.gov](http://www.SSA.gov). You may also get this form by calling 800-772-1213. Use Form W-7, Application for IRS Individual Taxpayer Identification Number, to apply for an ITIN, or Form SS-4, Application for Employer Identification Number, to apply for an EIN. You can apply for an EIN online by accessing the IRS website at [www.irs.gov/EIN](http://www.irs.gov/EIN). Go to [www.irs.gov/Forms](http://www.irs.gov/Forms) to view, download, or print Form W-7 and/or Form SS-4. Or, you can go to [www.irs.gov/OrderForms](http://www.irs.gov/OrderForms) to place an order and have Form W-7 and/or Form SS-4 mailed to you within 15 business days.

If you are asked to complete Form W-9 but do not have a TIN, apply for a TIN and enter "Applied For" in the space for the TIN, sign and date the form, and give it to the requester. For interest and dividend payments, and certain payments made with respect to readily tradable instruments, you will generally have 60 days to get a TIN and give it to the requester before you are subject to backup withholding on payments. The 60-day rule does not apply to other types of payments. You will be subject to backup withholding on all such payments until you provide your TIN to the requester.

**Note:** Entering "Applied For" means that you have already applied for a TIN or that you intend to apply for one soon. See also *Establishing U.S. status for purposes of chapter 3 and chapter 4 withholding*, earlier, for when you may instead be subject to withholding under chapter 3 or 4 of the Code.

**Caution:** A disregarded U.S. entity that has a foreign owner must use the appropriate Form W-8.

## Part II. Certification

To establish to the withholding agent that you are a U.S. person, or resident alien, sign Form W-9. You may be requested to sign by the withholding agent even if item 1, 4, or 5 below indicates otherwise.

For a joint account, only the person whose TIN is shown in Part I should sign (when required). In the case of a disregarded entity, the person identified on line 1 must sign. Exempt payees, see *Exempt payee code*, earlier.

**Signature requirements.** Complete the certification as indicated in items 1 through 5 below.

**1. Interest, dividend, and barter exchange accounts opened before 1984 and broker accounts considered active during 1983.** You must give your correct TIN, but you do not have to sign the certification.

**2. Interest, dividend, broker, and barter exchange accounts opened after 1983 and broker accounts considered inactive during 1983.** You must sign the certification or backup withholding will apply. If you are subject to backup withholding and you are merely providing your correct TIN to the requester, you must cross out item 2 in the certification before signing the form.

**3. Real estate transactions.** You must sign the certification. You may cross out item 2 of the certification.

**4. Other payments.** You must give your correct TIN, but you do not have to sign the certification unless you have been notified that you have previously given an incorrect TIN. "Other payments" include payments made in the course of the requester's trade or business for rents, royalties, goods (other than bills for merchandise), medical and health care services (including payments to corporations), payments to a nonemployee for services, payments made in settlement of payment card and third-party network transactions, payments to certain fishing boat crew members and fishermen, and gross proceeds paid to attorneys (including payments to corporations).

**5. Mortgage interest paid by you, acquisition or abandonment of secured property, cancellation of debt, qualified tuition program payments (under section 529), ABLÉ accounts (under section 529A), IRA, Coverdell ESA, Archer MSA or HSA contributions or distributions, and pension distributions.** You must give your correct TIN, but you do not have to sign the certification.

## What Name and Number To Give the Requester

For this type of account:	Give name and SSN of:
1. Individual	The individual
2. Two or more individuals (joint account) other than an account maintained by an FFI	The actual owner of the account or, if combined funds, the first individual on the account <sup>1</sup>
3. Two or more U.S. persons (joint account maintained by an FFI)	Each holder of the account
4. Custodial account of a minor (Uniform Gift to Minors Act)	The minor <sup>2</sup>
5. a. The usual revocable savings trust (grantor is also trustee)	The grantor-trustee <sup>1</sup>
b. So-called trust account that is not a legal or valid trust under state law	The actual owner <sup>1</sup>
6. Sole proprietorship or disregarded entity owned by an individual	The owner <sup>3</sup>
7. Grantor trust filing under Optional Filing Method 1 (see Regulations section 1.671-4(b)(2)(i)(A)) <sup>**</sup>	The grantor <sup>4</sup>

For this type of account:	Give name and EIN of:
8. Disregarded entity not owned by an individual	The owner
9. A valid trust, estate, or pension trust	Legal entity <sup>4</sup>
10. Corporation or LLC electing corporate status on Form 8832 or Form 2553	The corporation
11. Association, club, religious, charitable, educational, or other tax-exempt organization	The organization
12. Partnership or multi-member LLC	The partnership
13. A broker or registered nominee	The broker or nominee
14. Account with the Department of Agriculture in the name of a public entity (such as a state or local government, school district, or prison) that receives agricultural program payments	The public entity
15. Grantor trust filing Form 1041 or under the Optional Filing Method 2, requiring Form 1099 (see Regulations section 1.671-4(b)(2)(i)(B)) <sup>**</sup>	The trust

<sup>1</sup> List first and circle the name of the person whose number you furnish. If only one person on a joint account has an SSN, that person's number must be furnished.

<sup>2</sup> Circle the minor's name and furnish the minor's SSN.

<sup>3</sup> You must show your individual name on line 1, and enter your business or DBA name, if any, on line 2. You may use either your SSN or EIN (if you have one), but the IRS encourages you to use your SSN.

<sup>4</sup> List first and circle the name of the trust, estate, or pension trust. (Do not furnish the TIN of the personal representative or trustee unless the legal entity itself is not designated in the account title.)

<sup>\*</sup> **Note:** The grantor must also provide a Form W-9 to the trustee of the trust.

<sup>\*\*</sup> For more information on optional filing methods for grantor trusts, see the Instructions for Form 1041.

**Note:** If no name is circled when more than one name is listed, the number will be considered to be that of the first name listed.

## Secure Your Tax Records From Identity Theft

Identity theft occurs when someone uses your personal information, such as your name, SSN, or other identifying information, without your permission to commit fraud or other crimes. An identity thief may use your SSN to get a job or may file a tax return using your SSN to receive a refund.

To reduce your risk:

- Protect your SSN,
- Ensure your employer is protecting your SSN, and
- Be careful when choosing a tax return preparer.

If your tax records are affected by identity theft and you receive a notice from the IRS, respond right away to the name and phone number printed on the IRS notice or letter.

If your tax records are not currently affected by identity theft but you think you are at risk due to a lost or stolen purse or wallet, questionable credit card activity, or a questionable credit report, contact the IRS Identity Theft Hotline at 800-908-4490 or submit Form 14039.

For more information, see Pub. 5027, Identity Theft Information for Taxpayers.

Victims of identity theft who are experiencing economic harm or a systemic problem, or are seeking help in resolving tax problems that have not been resolved through normal channels, may be eligible for Taxpayer Advocate Service (TAS) assistance. You can reach TAS by calling the TAS toll-free case intake line at 877-777-4778 or TTY/TDD 800-829-4059.

**Protect yourself from suspicious emails or phishing schemes.** Phishing is the creation and use of email and websites designed to mimic legitimate business emails and websites. The most common act is sending an email to a user falsely claiming to be an established legitimate enterprise in an attempt to scam the user into surrendering private information that will be used for identity theft.

The IRS does not initiate contacts with taxpayers via emails. Also, the IRS does not request personal detailed information through email or ask taxpayers for the PIN numbers, passwords, or similar secret access information for their credit card, bank, or other financial accounts.

If you receive an unsolicited email claiming to be from the IRS, forward this message to [phishing@irs.gov](mailto:phishing@irs.gov). You may also report misuse of the IRS name, logo, or other IRS property to the Treasury Inspector General for Tax Administration (TIGTA) at 800-366-4484. You can forward suspicious emails to the Federal Trade Commission at [spam@uce.gov](mailto:spam@uce.gov) or report them at [www.ftc.gov/complaint](http://www.ftc.gov/complaint). You can contact the FTC at [www.ftc.gov/idtheft](http://www.ftc.gov/idtheft) or 877-IDTHEFT (877-438-4338). If you have been the victim of identity theft, see [www.IdentityTheft.gov](http://www.IdentityTheft.gov) and Pub. 5027.

Go to [www.irs.gov/IdentityTheft](http://www.irs.gov/IdentityTheft) to learn more about Identity theft and how to reduce your risk.

## Privacy Act Notice

Section 6109 of the Internal Revenue Code requires you to provide your correct TIN to persons (including federal agencies) who are required to file information returns with the IRS to report interest, dividends, or certain other income paid to you; mortgage interest you paid; the acquisition or abandonment of secured property; the cancellation of debt; or contributions you made to an IRA, Archer MSA, or HSA. The person collecting this form uses the information on the form to file information returns with the IRS, reporting the above information. Routine uses of this information include giving it to the Department of Justice for civil and criminal litigation and to cities, states, the District of Columbia, and U.S. commonwealths and territories for use in administering their laws. The information may also be disclosed to other countries under a treaty, to federal and state agencies to enforce civil and criminal laws, or to federal law enforcement and intelligence agencies to combat terrorism. You must provide your TIN whether or not you are required to file a tax return. Under section 3406, payors must generally withhold a percentage of taxable interest, dividends, and certain other payments to a payee who does not give a TIN to the payor. Certain penalties may also apply for providing false or fraudulent information.

