

Date: December 16, 2024

To: Governing Body

From: Joshua Bohlman, Public Works Project Manager *Joshua Bohlman*

Via: Regina Wheeler, Public Works Director *Regina Wheeler*
Sam Burnett, Facilities Division Director *JOHN BURNETT* (Dec 17, 2024 12:41 MST)
Melissa McDonald, Parks and Open Space Director *Melissa McDonald*

Subject: Railyard Irrigation & Water Harvesting Repair and Construction

Vendor Name: Accent Landscape Contractors, Inc.

Vendor Number: 9331

ACTION:

Request for Approval of General Services Contract with Accent Landscape Contractors, Inc. in the Total Amount of \$637,807.74 for the Railyard Park Irrigation and Water Harvesting System Replacement and Repairs with Term Ending June 30, 2026. (Joshua Bohlman, Public Works Project Manager, jbohlman@santafenm.gov)

Request for Approval of a Budget Amendment Resolution (BAR) to Allocate \$750,000 From the Railyard Fund Balance Into Railyard Operations – WIP Construction to Cover the Cost of the Railyard Irrigation and Water Harvesting Improvements.

CONTRACT NUMBER:

The FY25 Munis Contract Number is 3250258.

BACKGROUND AND SUMMARY:

The horticulture in the Railyard Park is a primary feature of the park and provides free education and experience of a biodiversity of native and drought tolerant plants for residents and visitors. The plants and trees in the park are struggling because the irrigation system, built in 2008, is past its useful life and must be replaced with an upgraded system. This new irrigation system is essential to preserve the plants and trees in the park and will provide considerably more efficient use of water while also enhancing the park's sustainability and aesthetics.

The Railyard water harvesting system has been largely inoperable for a number of years. The Facilities Division will restore the Railyard's water harvesting system. This currently inoperable infrastructure will be reactivated to capture roof runoff, supplementing the new irrigation system and further promoting responsible water use.

These two projects reestablish the demonstration of holistic water management, that is a fundamental feature of the park.

The included BAR will transfer funding from the Railyard's fund balance into operations to cover the cost of both the new irrigation system (\$637,807) and water harvesting (\$112,193) projects.

ATTACHMENTS:

General Services Contract

Proposal

New Mexico State Price Agreement #30-000000-23-00091

Certificate of Insurance

Horizons Declination

CPO Determination

BAR

PROCUREMENT METHOD:

The procurement method is New Mexico State Price Agreement, General Services #30-000000-23-00091 which expires July 20, 2025.

Chief Procurement Officer (CPS)/Designee:  Date: Jan 22, 2025
CPO Comment/Exceptions: NMSA 1978, Section 13-1-129

FUNDING SOURCE:

Fund Name/Number: Railyard/515
Munis Org Name/Number: Railyard Operations/5150403
Munis Object Name/Number: WIP Construction/572970

Budget Officer/Designee:  ALEXIS LOTERO (Jan 21, 2025 15:02 MST) Date: Jan 21, 2025
Budget Officer Comment/Exceptions: _____

ASSOCIATED APPROVALS:

IT Components included? Yes | No

Approval: _____ Date: _____
Comment/Exceptions: _____

Vehicles included? Yes | No

Approval: _____ Date: _____
Comment/Exceptions: _____

Construction, Facilities, Furniture, Fixtures, Equipment included? Yes | No

Approval: _____
Comment/Exceptions: _____
Signature:  JOHN BURNETT (Dec 17, 2024 12:41 MST)
Email: jsburnett@santafenm.gov

Capital Asset* or Project?** Yes | No

Project Ledger#: PWA2551501
(*will this procurement result in a tangible item that costs more than \$5,000?)
(**Capital Projects are new and improvement projects that are going to cost \$10,000 or more)
Approval:  Date: Jan 22, 2025
Comment/Exceptions: _____

Is this a Grant Funded Purchase? Yes | No

Approval: _____ Title: _____ Date: _____
Comment/Exceptions: _____

Anticipated length of project: completion on or before 6/30/2026

Department Contract Administrator Contact Info:
Elizabeth L. Kahahane (elkahahane@santafenm.gov)

**CITY OF SANTA FE
GENERAL SERVICES CONTRACT**

Railyard Irrigation Installation Services

THIS CONTRACT is made and entered into by and between the City of Santa Fe, herein after referred to as the "City," and **Accent Landscape Contractors Inc.**, herein after referred to as the "Contractor."

IT IS MUTUALLY AGREED BETWEEN THE PARTIES:

1. **Definitions**

- A. "Products and Services Schedule" refers to the complete list of products and services offered under this Contract and the price for each. Product and service descriptions may be amended with the prior approval of the Contract Administrator. New products and services shall not be added to the Products and Services Schedule.
- B. "Business Hours" means 8:00 a.m. to 5:00 p.m. Mountain Time.

2. **Scope of Work**

- A. The Contractor shall perform the following work:

Install a new irrigation system at the S.F. Railroad Park as per the plans by Pland Collaborative dated 8/6/2024.

3. **Compensation**

Compensation Schedule. The City shall pay to the Contractor based upon fixed prices for each Deliverable, per the schedule outlined in Exhibit A, less retainage, if any, as identified in paragraph C of this Clause..

- A. **Payment.** The total compensation under this Agreement shall not exceed \$637,807.74, including New Mexico gross receipts tax and 20% contingency. This amount is a maximum and not a guarantee that the work assigned to be performed by Contractor under this Agreement shall equal the amount stated herein. The Parties do not intend for the Contractor to continue to provide Services without compensation when the total compensation amount is reached. Contractor is responsible for notifying the City when the Services provided under this Agreement reach the total compensation amount. In no event will the Contractor be paid for Services provided in excess of the total compensation amount without this Agreement being amended in writing prior to services, in excess of the total compensation amount being provided.
- B. **Payment** shall be made upon Acceptance of each Deliverable and upon the receipt and Acceptance of a detailed, certified Payment Invoice. Payment will be made to the Contractor's designated mailing address. In accordance with Section 13-1-158 NMSA 1978, payment shall be tendered to

the Contractor within thirty (30) days of the date of written certification of Acceptance. All Payment Invoices MUST BE received by the City no later than fifteen (15) days after the termination of this Agreement. Payment Invoices received after such date WILL NOT BE PAID.

C. Retainage. Not Applicable. The Parties agree there is no retainage.

D. Performance Bond. Not Applicable. The Parties agree that is Performance Bond.

4. **Term**

THIS CONTRACT SHALL NOT BECOME EFFECTIVE UNTIL APPROVED IN WRITING BY THE CITY. This contract shall terminate **June 30, 2026**.

5. **Default and Force Majeure**

The City reserves the right to cancel all, or any part of any orders placed under this contract without cost to the City, if the Contractor fails to meet the provisions of this contract and, except as otherwise provided herein, to hold the Contractor liable for any excess cost occasioned by the City due to the Contractor's default. The Contractor shall not be liable for any excess costs if failure to perform the order arises out of causes beyond the control and without the fault or negligence of the Contractor; such causes include, but are not restricted to, acts of God or the public enemy, acts of the State or Federal Government, fires, floods, epidemics, quarantine restrictions, strikes, freight embargoes, unusually severe weather and defaults of sub-contractors due to any of the above, unless the City shall determine that the supplies or services to be furnished by the sub-contractor were obtainable from other sources in sufficient time to permit the Contractor to meet the required delivery scheduled. The rights and remedies of the City provided in this paragraph shall not be exclusive and are in addition to any other rights now being provided by law or under this contract.

6. **Termination**

A. Grounds. The City may terminate this Contract for convenience or cause. For contracts within their authority, the City Manager or their designee is authorized to provide the notice of termination, otherwise such notice of termination shall be provided by the Mayor, or their designee as authorized by the Governing Body. The Contractor may only terminate this Contract based upon the City's uncured, material breach of this Contract.

B. Notice: City Opportunity to Cure.

1) The City shall give the Contractor written notice of termination at least thirty (30) days prior to the intended date of termination.

2) Contractor shall give City written notice of termination at least thirty (30) days prior to the intended date of termination, which notice shall (i) identify all the City's material breaches of this Contract upon which the termination is based and (ii) state what the City must do to cure such material breaches. Contractor's notice of termination shall only be effective (i) if the City does not cure all material breaches within the thirty (30) day notice period or (ii) in the case of material breaches that cannot be cured within thirty (30) days, the City does not, within the thirty (30) day notice period, notify the Contractor of its intent to cure and begin with due diligence to cure the material breach.

3) Notwithstanding the foregoing, this Contract may be terminated immediately upon written notice to the Contractor (i) if the Contractor becomes unable to perform the services contracted for, as determined by the City; (ii) if, during the term of this Contract, the Contractor is suspended or debarred by the City; or (iii) the Contract is terminated pursuant to Paragraph 17, "Appropriations", of this Contract.

C. Liability. Except as otherwise expressly allowed or provided under this Contract, the City's sole liability upon termination shall be to pay for acceptable work performed prior to the Contractor's receipt or issuance of a notice of termination; provided, however, that a notice of termination shall not nullify or otherwise affect either party's liability for pre-termination defaults under or breaches of this Contract. The Contractor shall submit an invoice for such work within thirty (30) days of receiving or sending the notice of termination. *THIS PROVISION IS NOT EXCLUSIVE AND DOES NOT WAIVE THE CITY'S OTHER LEGAL RIGHTS AND REMEDIES CAUSED BY THE CONTRACTOR'S DEFAULT/BREACH OF THIS CONTRACT.*

7. **Amendment**

A. This Contract shall not be altered, changed, or amended except by instrument in writing executed by the parties hereto and all other required signatories.

B. If the City proposes an amendment to the Contract to unilaterally reduce funding due to budget or other considerations, the Contractor shall, within thirty (30) days of receipt of the proposed Amendment, have the option to terminate the Contract, pursuant to the termination provisions as set forth in Paragraph 7 herein, or to agree to the reduced funding.

8. **Status of Contractor**

The Contractor, and Contractor's agents and employees, are independent Contractors for the City and are not employees of the City. The Contractor, and Contractor's agents and employees, shall not accrue leave, retirement, insurance, bonding, use of City vehicles, or any other benefits afforded to employees of the City because of this Contract. The Contractor acknowledges that all sums received hereunder are personally reportable by the Contractor for income tax purposes, including without limitation, self-employment tax and business income tax. The Contractor agrees not to purport to bind the City unless the Contractor has written authority to do so, and then only within the strict limits of that authority.

9. **Assignment**

The Contractor shall not assign or transfer any interest in this Contract or assign any claims for money due or to become due under this Contract without the prior written approval of the City.

10. **Subcontracting**

The Contractor shall not subcontract any portion of the services to be performed under this Contract without the prior written approval of the City. No such subcontract shall relieve the primary Contractor from its obligations and liabilities under this Contract, nor shall any subcontract obligate direct payment from the City.

11. **Non-Collusion**

In signing this Contract, the Contractor certifies the Contractor has not, either directly or indirectly, entered into action in restraint of free competitive bidding in connection with this offer submitted to the City.

12. **Inspection of Plant**

The City may inspect, at any reasonable time during Contractor's regular business hours and upon prior written notice, the Contractor's plant or place of business, or any subcontractor's plant or place of business, which is related to the performance of this contract.

13. **Commercial Warranty**

The Contractor agrees that the tangible personal property or services furnished under this Contract shall be covered by the most favorable commercial warranties the Contractor gives to any customer for such tangible personal property or services, and that the rights and remedies provided herein shall extend to the City and are in addition to and do not limit any rights afforded to the City by any other clause of this order. The contractor agrees not to disclaim warranties of fitness for a particular purpose or merchantability.

14. **Condition of Proposed Items**

Where tangible personal property is a part of this Contract, all proposed items are to be NEW and of most current production, unless otherwise specified.

15. **Records and Audit**

During the term of this Contract and for three years thereafter, the Contractor shall maintain detailed records pertaining to the services rendered and products delivered. These records shall be subject to inspection by the City, the State Auditor and other appropriate state and federal authorities. The City shall have the right to audit billings both before and after payment. Payment under this Contract shall not foreclose the right of the City to recover excessive or illegal payments.

16. **Appropriations**

The terms of this Contract, and any orders placed under it, are contingent upon sufficient appropriations and authorization being made by the Governing Body for the performance of this Contract. If sufficient appropriations and authorization are not made by the legislature, this Contract, and any orders placed under it, shall terminate upon written notice being given by the City to the Contractor. The City's decision as to whether sufficient appropriations are available shall be accepted by the Contractor and shall be final. If the City proposes an amendment to the Contract to unilaterally reduce funding, the Contractor shall have the option to terminate the Contract or to agree to the reduced funding, within thirty (30) days of receipt of the proposed amendment.

17. **Release**

The Contractor, upon final payment of the amount due under this Contract, releases the City, its officers, and employees, from all liabilities, claims and obligations whatsoever arising from or under this Contract. The Contractor agrees not to purport to bind the City, unless the Contractor has express written authority to do so, and then only within the strict limits of that authority.

18. **Confidentiality**

Any confidential information provided to or developed by the Contractor in the performance of this Contract shall be kept confidential and shall not be made available to any individual or organization by the Contractor without prior written approval by the City.

19. **Conflict of Interest**

A. The Contractor represents and warrants that it presently has no interest and, during the term of this Contract, shall not acquire any interest, direct or indirect, which would conflict in any manner or degree with the performance or services required under the Contract. The Contractor shall comply with any applicable provisions of the New Mexico Governmental Conduct Act and the New Mexico Financial Disclosures Act.

B. The Contractor further represents and warrants that it has complied with, and, during the term of this Contract, will continue to comply with, and that this Contract complies with all applicable provisions of the Governmental Conduct Act, Chapter 10, Article 16 NMSA 1978.

C. Contractor's representations and warranties in Paragraphs A and B of this Paragraph are material representations of fact upon which the City relied when this Contract was entered into by the parties. Contractor shall provide immediate written notice to the City if, at any time during the term of this Contract, Contractor learns that Contractor's representations and warranties in Paragraphs A and B of this Paragraph 20 were erroneous on the effective date of this Contract or have become erroneous by reason of new or changed circumstances. If it is later determined that Contractor's representations and warranties in Paragraphs A and B of this Paragraph 20 were erroneous on the effective date of this Contract or have become erroneous by reason of new or changed circumstances, in addition to other remedies available to the City and notwithstanding anything in the Contract to the contrary, the City may immediately terminate the Contract.

D. All terms defined in the Governmental Conduct Act have the same meaning in this section.

20. **Approval of Contractor Representative(s)**

The City reserves the right to require a change in Contractor representative(s) if the assigned representative(s) are not, in the opinion of the City, adequately serving the needs of the City.

21. **Scope of Contract; Merger**

This Contract incorporates all the Agreements, covenants and understandings between the parties hereto concerning the subject matter hereof, and all such covenants, agreements, and understandings have been merged into this written contract.

Statewide/Existing Agreements 13-1-129

This Contract is issued against the state or agency Master Agreement, established, and maintained by the New Mexico State Price Agreement, General Services #30-000000-23-00091, and through this language hereby incorporates this agreement by reference and is included in the order of precedence.

22. **Notice**

The Procurement Code, NMSA 1978, Sections 13-1-28 through 13-1-199, imposes civil and criminal penalties for its violation. In addition, the New Mexico criminal statutes impose felony penalties for bribes, gratuities, and kickbacks.

23. **Equal Opportunity Compliance**

The Contractor agrees to abide by all federal and state laws, and local Ordinances, pertaining to equal employment opportunity. In accordance with all such laws, rules, and regulations, the Contractor agrees to assure that no person in the United States shall on the grounds of race, religion, color, national origin, ancestry, sex, age, physical or mental handicap, or serious medical condition, spousal affiliation, sexual orientation or gender identity, be excluded from employment with or participation in, be denied the benefits of, or be otherwise subjected to discrimination under any program or activity performed under this Contract. If Contractor is found not to be in compliance with these requirements during the life of this Contract, Contractor agrees to take appropriate steps to correct these deficiencies.

24. **Indemnification**

The Contractor shall hold the City and its employees harmless and shall indemnify the City and its employees against any and all claims, suits, actions, liabilities and costs of any kind, including attorney's fees for personal injury or damage to property arising from the acts or omissions of the Contractor, its agents, officers, employees or subcontractors. The Contractor shall not be liable for any injury or damage as a result of any negligent act or omission committed by the City, its officers or employees.

25. **New Mexico Tort Claims Act**

Any liability incurred by the City of Santa Fe in connection with this Contract is subject to the immunities and limitations of the New Mexico Tort Claims Act, Section 41-4-1, et. seq. NMSA 1978, as amended. The City and its "public employees" as defined in the New Mexico Tort Claims Act, do not waive sovereign immunity, do not waive any defense and do not waive any limitation of liability pursuant to law. No provision in this Contract modifies or waives any provision of the New Mexico Tort Claims Act.

26. **Applicable Law**

The laws of the State of New Mexico shall govern this Contract, without giving effect to its choice of law provisions. Venue shall be proper only in a New Mexico court of competent jurisdiction in accordance with NMSA 1978, Section 38-3-2. By execution of this Contract, Contractor acknowledges and agrees to the jurisdiction of the courts of the State of New Mexico over any and all lawsuits arising under or out of any term of this Contract.

27. **Limitation of Liability**

The Contractor's liability to the City, for any cause whatsoever shall be limited to the purchase price paid to the Contractor for the products and services that are the subject of the City's, claim. The foregoing limitation does not apply to paragraph 25 of this Contract or to damages resulting from personal injury caused by the Contractor's negligence.

28. **Incorporation by Reference and Precedence**

If this Contract has been procured pursuant to a request for proposals, this Contract is derived from (1) the request for proposal, (including any written clarifications to the request for proposals and any City response to questions); (2) the Contractor's best and final offer; and (3) the Contractor's response to the request for proposals.

In the event of a dispute under this Contract, applicable documents will be referred to for the purpose of clarification or for additional detail in the following order of precedence: (1) amendments to the Contract in reverse chronological order; (2) the Contract, including the scope of work and all terms and conditions thereof; (3) the request for proposals, including attachments thereto and written responses to questions and written clarifications; (4) the Contractor's best and final offer if such has been made and accepted by the City; and (5) the Contractor's response to the request for proposals.

29. **Workers' Compensation**

The Contractor agrees to comply with state laws and rules applicable to workers' compensation benefits for its employees. If the Contractor fails to comply with the Workers' Compensation Act and applicable rules when required to do so, this Contract may be terminated by the City.

30. **Inspection**

If this contract is for the purchase of tangible personal property (goods), final inspection and acceptance shall be made at Destination. Tangible personal property rejected at Destination for non-conformance to specifications shall be removed at Contractor's risk and expense promptly after notice of rejection and shall not be allowable as billable items for payment.

31. **Inspection of Services**

If this contract is for the purchase of services, the following terms shall apply.

A. Services, as used in this Article, include services performed, workmanship, and material furnished or utilized in the performance of services.

B. The Contractor shall provide and maintain an inspection system acceptable to the City covering the services under this Contract. Complete records of all inspection work performed by the Contractor shall be maintained and made available to the City and for as long thereafter as the Contract requires. The City has the right to inspect and test all services contemplated under this Contract to the extent practicable at all times and places during the term of the Contract. The City shall perform inspections and tests in a manner that will not unduly delay or interfere with Contractor's performance.

C. If the City performs inspections or tests on the premises of the Contractor or a subcontractor, the Contractor shall furnish, and shall require subcontractors to furnish, at no increase in contract price, all reasonable facilities and assistance for the safe and convenient performance of such inspections or tests.

D. If any part of the services do not conform with the requirements of this Contract, the City may require the Contractor to re-perform the services in conformity with the requirements of this Contract at no increase in contract amount. When the defects in services cannot be corrected by re-performance, the City may:

- (1) require the Contractor to take necessary action(s) to ensure that future performance conforms to the requirements of this Contract; and
- (2) reduce the contract price to reflect the reduced value of the services performed.

E. If the Contractor fails to promptly re-perform the services or to take the necessary action(s) to ensure future performance in conformity with the requirements of this Contract, the City may:

- (1) by contract or otherwise, perform the services and charge to the Contractor any cost incurred by the City that is directly related to the performance of such service; or
- (2) terminate the contract for default.

32. **Insurance**

If the services contemplated under this Contract will be performed on or in City facilities or property, Contractor shall maintain in force during the entire term of this Contract, the following insurance coverage(s), naming the City as additional insured.

A. Commercial General Liability insurance shall be written on an occurrence basis and be a broad as ISO Form CG 00 01 with limits not less than \$2,000,000 per occurrence and \$2,000,000 in the aggregate for claims against bodily injury, personal and advertising injury, and property damage. Said policy shall include broad form Contractual Liability coverage and be endorsed to name the City of Santa Fe their officials, officers, employees, and agents as additional insureds.

B. Business Automobile Liability insurance for all owned, non-owned automobiles, with a combined single limit not less than \$1,000,000 per accident.

C. Broader Coverage and Limits. The insurance requirements under this Contract shall be the greater of (1) the minimum coverage and limits specified in this Contract, or (2) the broader coverage and maximum limits of coverage of any insurance policy or proceeds available to the Named Insured. It is agreed that these insurance requirements shall not in any way act to reduce coverage that is broader or that includes higher limits than the minimums required herein. No representation is made that the minimum insurance requirements of this Contract are sufficient to cover the obligations of Contractor hereunder.

D. Contractor shall maintain the above insurance for the term of this Contract and name the City as an additional insured and provide for 30 days cancellation notice on any Certificate of Insurance form furnished by Contractor. Such certificate shall also specifically state the coverage provided under the policy is primary over any other valid and collectible insurance and provide a waiver of subrogation.

33. **Impracticality of Performance**

A party shall be excused from performance under this Contract for any period that the party is prevented from performing as a result of an act of God, strike, war, civil disturbance, epidemic, or court order, provided that the party has prudently and promptly acted to take any and all steps that are within the party's control to ensure performance. Subject to this provision, such non-performance shall not be deemed a default or a ground for termination.

34. **Invalid Term or Condition**

If any term or condition of this Contract shall be held invalid or unenforceable, the remainder of this Contract shall not be affected and shall be valid and enforceable.

35. **Enforcement of Contract**

A party's failure to require strict performance of any provision of this Contract shall not waive or diminish that party's right thereafter to demand strict compliance with that or any other provision. No waiver by a party of any of its rights under this Contract shall be effective unless express and in writing, and no effective waiver by a party of any of its rights shall be effective to waive any other rights.

36. **Patent, Copyright and Trade Secret Indemnification**

A. The Contractor shall defend, at its own expense, the City against any claim that any product or service provided under this Contract infringes any patent, copyright to trademark in the United States or Puerto Rico, and shall pay all costs, damages and attorneys' fees that a court finally awards as a result of any such claim. In addition, if any third party obtains a judgment against the City based upon Contractor's trade secret infringement relating to any product or services provided under this Contract, the Contractor agrees to reimburse the City for all costs, attorneys' fees and amount of the judgment. To qualify for such defense and or payment, the City shall:

- 1) give the Contractor prompt written notice within 48 hours of any claim;
- 2) allow the Contractor to control the defense of settlement of the claim; and
- 3) cooperate with the Contractor in a reasonable way to facilitate the defense or settlement

of the claim.

B. If any product or service becomes, or in the Contractor's opinion is likely to become the subject of a claim of infringement, the Contractor shall at its option and expense:

- 1) provide the City the right to continue using the product or service and fully indemnify the City against all claims that may arise out of the City's use of the product or service;
- 2) replace or modify the product or service so that it becomes non-infringing; or,
- 3) accept the return of the product or service and refund an amount equal to the value of the returned product or service, less the unpaid portion of the purchase price and any other amounts, which are due to the Contractor. The Contractor's obligation will be void as to any product or service modified by the City to the extent such modification is the cause of the claim.

37. **Survival**

The Contract paragraphs titled "Patent, Copyright, Trademark, and Trade Secret Indemnification; Indemnification; and Limit of Liability" shall survive the expiration of this Contract. Software licenses, leases, maintenance and any other unexpired Agreements that were entered into under the terms and conditions of this Contract shall survive this Contract.

38. **Disclosure Regarding Responsibility**

A. Any prospective Contractor and any of its Principals who enter into a contract greater than sixty thousand dollars (\$60,000.00) with any City for professional services, tangible personal property, services or construction agrees to disclose whether the Contractor, or any principal of the Contractor's company is presently debarred, suspended, proposed for debarment, or declared ineligible for award of contract by any federal entity, state agency or local public body.

B. Principal, for the purpose of this disclosure, means an officer, director, owner, partner, or a person having primary management or supervisory responsibilities within a business entity or related entities.

C. The Contractor shall provide immediate written notice to the City if, at any time during the term of this Contract, the Contractor learns that the Contractor's disclosure was at any time erroneous or became erroneous by reason of changed circumstances.

D. A disclosure that any of the items in this requirement exist will not necessarily result in termination of this Contract. However, the disclosure will be considered in the determination of the Contractor's responsibility and ability to perform under this Contract. Failure of the Contractor to furnish a disclosure or provide additional information as requested will be grounds for immediate termination of this Contract pursuant to the conditions set forth in Paragraph 7 of this Contract.

E. Nothing contained in the foregoing shall be construed to require establishment of a system of records in order to render, in good faith, the disclosure required by this document. The knowledge and information of a Contractor is not required to exceed that which is the normally possessed by a prudent person in the ordinary course of business dealings.

F. The disclosure requirement provided is a material representation of fact upon which reliance was placed when making an award and is a continuing material representation of the facts during the term of this Contract. If during the performance of the contract, the Contractor is indicted for or otherwise criminally or civilly charged by any government entity (federal, state or local) with commission of any offenses named in this document the Contractor must provide immediate written notice to the City. If it is later determined that the Contractor knowingly rendered an erroneous disclosure, in addition to other remedies available to the Government, the City may terminate the involved contract for cause. Still further the City may suspend or debar the Contractor from eligibility for future solicitations until such time as the matter is resolved to the satisfaction of the City.

39. **Suspension, Delay or Interruption of Work**

The City may, without cause, order the Contractor, in writing, to suspend, delay or interrupt the work in whole or in part for such period of time as the City may determine. The contract sum and contract time shall be adjusted for increases in cost and/or time associated with Contractor's compliance therewith. Upon receipt of such notice, Contractor shall leave the jobsite and any equipment in a safe condition prior to departing. Contractor must assert rights to additional compensation within thirty (30) days after suspension of work is lifted and return to work is authorized. Any compensation requested for which entitlement is granted and the contract sum adjusted, shall have profit included (for work completed) and for cost only (not profit) for Contractor costs incurred directly tied to the suspension itself and not otherwise covered by Contract remedy. Any change in Total Compensation must be reflected in an Amendment executed pursuant to Section 8 of this Contract.

40. **Notification**

Either party may give written notice to the other party in accordance with the terms of this Paragraph. Any written notice required or permitted to be given hereunder shall be deemed to have been given on the date of delivery if delivered by personal service or hand delivery or three (3) business days after being mailed.

To the City: Josh Bohlman, CPO Project Manager City of Santa Fe – Facilities Division 2651 Siringo Road, Building E Santa Fe, NM 87505
To the Contractor: Cameron Stevens President Accent Landscape Contractors Inc. 5919 Edith Blvd. NE Albuquerque, NM 87107

41. **Succession**

This Contract shall extend to and be binding upon the successors and assigns of the parties.

IN WITNESS WHEREOF, the Parties have executed this Contract as of the date of the signature by the required approval authorities below.

CITY OF SANTA FE:

CONTRACTOR:

ALAN WEBBER, MAYOR



Cameron Stevens (Nov 12, 2024 10:28 MST)
CAMERON STEVENS, PRESIDENT

DATE: _____

DATE: **Nov 12, 2024**

NMBTIN: 002261620110620

ATTEST:

CITY CLERK

CITY ATTORNEY'S OFFICE:

Kevin L. Nault

Kevin L. Nault (Nov 12, 2024 16:52 MST)
ASSISTANT CITY ATTORNEY

APPROVED FOR FINANCES:

Emily K. Oster

FINANCE DIRECTOR



September 20, 2024

City of Santa Fe
Mr. Josh Bohlman, CPO
Project Administration

CC: Mario Nuno-Whelan
Pland Collaborative Landscape Architects
RE: S.F. Railroad Park irrigation Renovation

Dear Mr. Bohlman,

The follow is our cost proposal to install a new irrigation system at the S.F. Railroad Park as per the plans by Pland Collaborative dated 8/6/2024.

Total cost:	\$483,975.00
NMGRT (8.1875%):	\$39,625.45
P&P Bonds:	\$7,906.00
Total:	\$531,506.45

Thank you for the opportunity to provide you with our proposal. Please contact our office if you have any questions.

Respectfully submitted,

A handwritten signature in blue ink, consisting of several overlapping loops and a long horizontal stroke extending to the right.











General Services_RYD Irrigation_ELK1_JB2_11 1 24_2983-final CAO with Exh A

Final Audit Report

2024-11-12

Created:	2024-11-07
By:	Amy Cawthon (amcawthon@santafenm.gov)
Status:	Signed
Transaction ID:	CBJCHBCAABAACkeGkHtIV03fJlvFKInzYwFKZ00MBe5N

"General Services_RYD Irrigation_ELK1_JB2_11 1 24_2983-fina I CAO with Exh A" History

-  Document created by Amy Cawthon (amcawthon@santafenm.gov)
2024-11-07 - 6:43:52 PM GMT- IP address: 63.232.20.2
-  Document emailed to cstevens@accentnm.com for signature
2024-11-07 - 6:44:42 PM GMT
-  Email viewed by cstevens@accentnm.com
2024-11-08 - 8:43:43 AM GMT- IP address: 172.226.3.27
-  Email viewed by cstevens@accentnm.com
2024-11-10 - 6:32:06 AM GMT- IP address: 104.28.85.163
-  Email viewed by cstevens@accentnm.com
2024-11-12 - 5:56:47 AM GMT- IP address: 104.28.85.160
-  Signer cstevens@accentnm.com entered name at signing as Cameron Stevens
2024-11-12 - 5:28:46 PM GMT- IP address: 174.50.94.154
-  Document e-signed by Cameron Stevens (cstevens@accentnm.com)
Signature Date: 2024-11-12 - 5:28:48 PM GMT - Time Source: server- IP address: 174.50.94.154
-  Document emailed to klnault@santafenm.gov for signature
2024-11-12 - 5:28:50 PM GMT
-  Email viewed by klnault@santafenm.gov
2024-11-12 - 11:51:56 PM GMT- IP address: 104.47.64.254
-  Signer klnault@santafenm.gov entered name at signing as Kevin L. Nault
2024-11-12 - 11:52:18 PM GMT- IP address: 63.232.20.2





Document e-signed by Kevin L. Nault (klnault@santafenm.gov)

Signature Date: 2024-11-12 - 11:52:20 PM GMT - Time Source: server- IP address: 63.232.20.2



Agreement completed.

2024-11-12 - 11:52:20 PM GMT



Powered by
Adobe
Acrobat Sign

Accent

Landscape Contractors Inc.

September 20, 2024

City of Santa Fe
Mr. Josh Bohlman, CPO
Project Administration

CC: Mario Nuno-Whelan
Pland Collaborative Landscape Architects
RE: S.F. Railroad Park irrigation Renovation

Dear Mr. Bohlman,

The follow is our cost proposal to install a new irrigation system at the S.F. Railroad Park as per the plans by Pland Collaborative dated 8/6/2024.

Total cost:	\$483,975.00
NMGRT (8.1875%):	\$39,625.45
P&P Bonds:	\$7,906.00
Total:	\$531,506.45

Thank you for the opportunity to provide you with our proposal. Please contact our office if you have any questions.

Respectfully submitted,

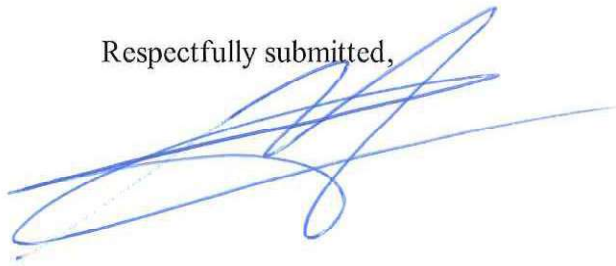

P.O. Box 30983

(505) 881-4880 Office

(505) 889-9446 Fax

Albuquerque, NM 87190

WWW.accentls.org

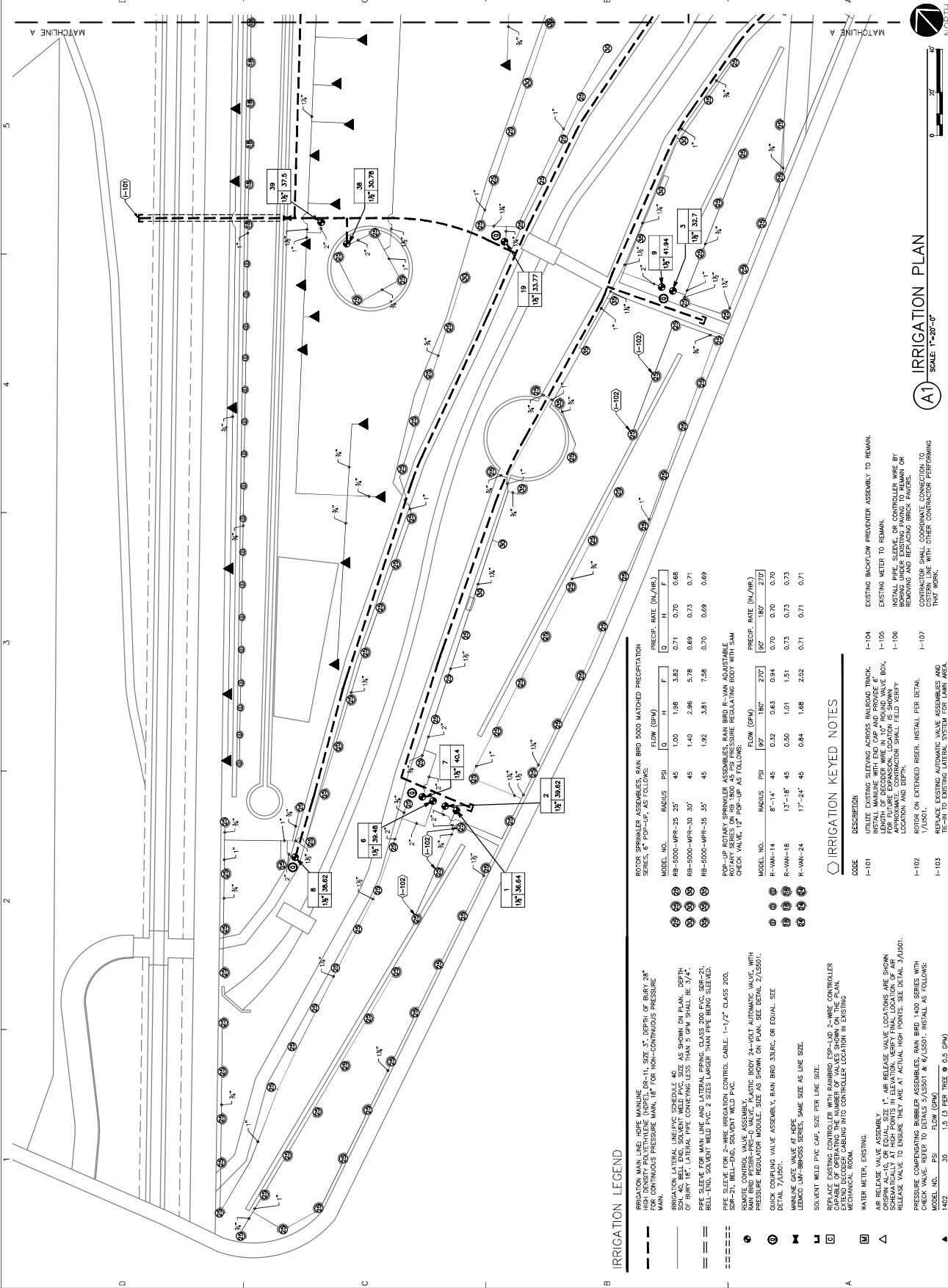

IRRIGATION LEGEND

- IRRIGATION MAIN LINE, HOPE MAINLINE, 1" SIZE 3" DEPTH OF BURY, 24" FOR CONTINUOUS PRESSURE MAIN, 18" FOR NON-CONTINUOUS PRESSURE MAIN.
- IRRIGATION LATERAL LINE, SCHEDULE 40, AS SHOWN ON PLAN. DEPTH OF BURY, 18". LATERAL PIPE COVERING LESS THAN 5" SHALL BE 3/4".
- == PIPE SLEEVES FOR MAIN LINE AND LATERAL PIPING, CLASS 200 PVC, SDR-21, BELL-END, SOLVENT WELD PVC, 2 SIZES LARGER THAN PIPE BEING SLEAVED.
- == PIPE SLEEVES FOR 2-WIRE IRRIGATION CONTROL CABLE, 1-1/2" CLASS 200, SDR-21, BELL-END, SOLVENT WELD PVC.
- ⊕ REMOTE CONTROL VALVE ASSEMBLY, PRESSURE REGULATING VALVE WITH PRESSURE REGULATOR MODULE, SIZE AS SHOWN ON PLAN. SEE DETAIL 2/LS001, DETAIL 7/LS001.
- ⊕ QUICK CLOSING VALVE ASSEMBLY, RAIN BRD 338.6K, OR EQUAL, SEE DETAIL 7/LS001.
- ⊕ MAINLINE GATE VALVE AT HOPE
- ⊕ LEMMO LOW-BROSS SERIES, SAME SIZE AS LINE SIZE.
- ⊕ SOLVENT WELD PVC CAP, SIZE PER LINE SIZE.
- ⊕ REPLACE EXISTING CONTROLLER WITH RAINBRD ESP-LDQ 2-WIRE CONTROLLER, CAPABLE OF OPERATING THE NUMBER OF VALVES SHOWN ON THE PLAN, INCLUDING THOSE CONTROLLING THE LOCATION IN EXISTING MECHANICAL ROOM.
- ⊕ WATER METER, EXISTING.
- ⊕ AIR RELEASE VALVE ASSEMBLY
- ⊕ CRISP AL-10, OR EQUAL, SIZE 1", AIR RELEASE VALVE LOCATIONS ARE SHOWN ON PLAN.
- ⊕ RELEASE VALVE TO ENSURE THEY ARE AT ACTUAL HIGH POINTS, SEE DETAIL 3/LS001.
- ⊕ PRESSURE COMPENSATING BUBBLE ASSEMBLY, RAIN BRD 1400 SERIES WITH CHECK VALVE. REFER TO DETAILS 5/LS001 & 6/LS001. INSTALL AS FOLLOWS:
- MODEL NO. PSI FLOW (GPM)
- 1402 30 1.5 (3 PER TREE @ 0.5 GPM)
- 1402 1.5 (3 PER TREE @ 0.5 GPM)

ROTOR SPRINKLER ASSEMBLIES, RAIN BRD 5000 MATCHED PRECIPITATION SERIES, 6" POP-UP, AS FOLLOWS:

MODEL NO.	RADIUS	PSI	Q	H	F	PRECIP. RATE (IN./HR.)
25	RB-5000-MPR-25 25'	45	1.00	1.98	3.82	0.71
26	RB-5000-MPR-30 30'	45	1.40	2.96	5.78	0.69
27	RB-5000-MPR-35 35'	45	1.92	3.81	7.58	0.69

POP-UP ROTARY SPRINKLER ASSEMBLIES, RAIN BRD P-VAN ADJUSTABLE ROTARY SERIES ON RB 1800-45 PSI PRESSURE REGULATING BODY WITH SAM CHECK VALVE, 12" POP-UP AS FOLLOWS:

MODEL NO.	RADIUS	PSI	Q	H	F	PRECIP. RATE (IN./HR.)
28	P-WAN-14	8'-14"	0.32	0.63	0.84	0.70
29	R-WAN-16	13'-16"	0.50	1.01	1.51	0.73
30	R-WAN-24	17'-24"	0.84	1.68	2.52	0.71

IRRIGATION KEYED NOTES

- I-101 UTILIZE EXISTING SLEEVES ACROSS RAILROAD TRACK. INSTALL MAINLINE WITH END CAP AND PROVIDE 6" DEPTH OF BURY. PROVIDE WIRE CLOTHED ROUND VALVE BOX. APPROXIMATE CONTRACTOR SHALL FIELD VERIFY LOCATION AND DEPTH.
- I-102 ON EXISTING RISER, INSTALL PER DETAIL 7/LS001.
- I-103 REPLACE EXISTING AUTOMATIC VALVE ASSEMBLY AND TIE-IN TO EXISTING LATERAL SYSTEM FOR LAWN AREA. MATCH EXISTING VALVE SIZE.
- I-104 EXISTING BACKFLOW PREVENTER ASSEMBLY TO REMAIN.
- I-105 EXISTING METER TO REMAIN.
- I-106 INSTALL PIPE SLEEVES OR CONTROLLER WIRE BY CONTRACTOR. CONTRACTOR SHALL VERIFY LOCATION, REMOVING AND REPAIRING BRICK PAVEMENT.
- I-107 CONTRACTOR SHALL COORDINATE CONNECTION TO EXISTING MAINLINE WITH OTHER CONTRACTOR PERFORMING THAT WORK.



(A1) IRRIGATION PLAN
SCALE: 1"=20'-0"

CONSULTANTS

**SANTA FE RAILYARD
PARK IRRIGATION
RENOVATION PLAN**

OCTOBER 1, 2024

SUBMITTAL: 100% FOR CONSTRUCTION

REVISIONS

NO. DATE DESCRIPTION

PROJECT NO: 22075
CAD DWG FILE:
DESIGNED BY: GMM/MW
DRAWN BY: MMW
CHECKED BY: GM
SHEET TITLE

**IRRIGATION
PLAN**

DRAWING SHEET
LI102

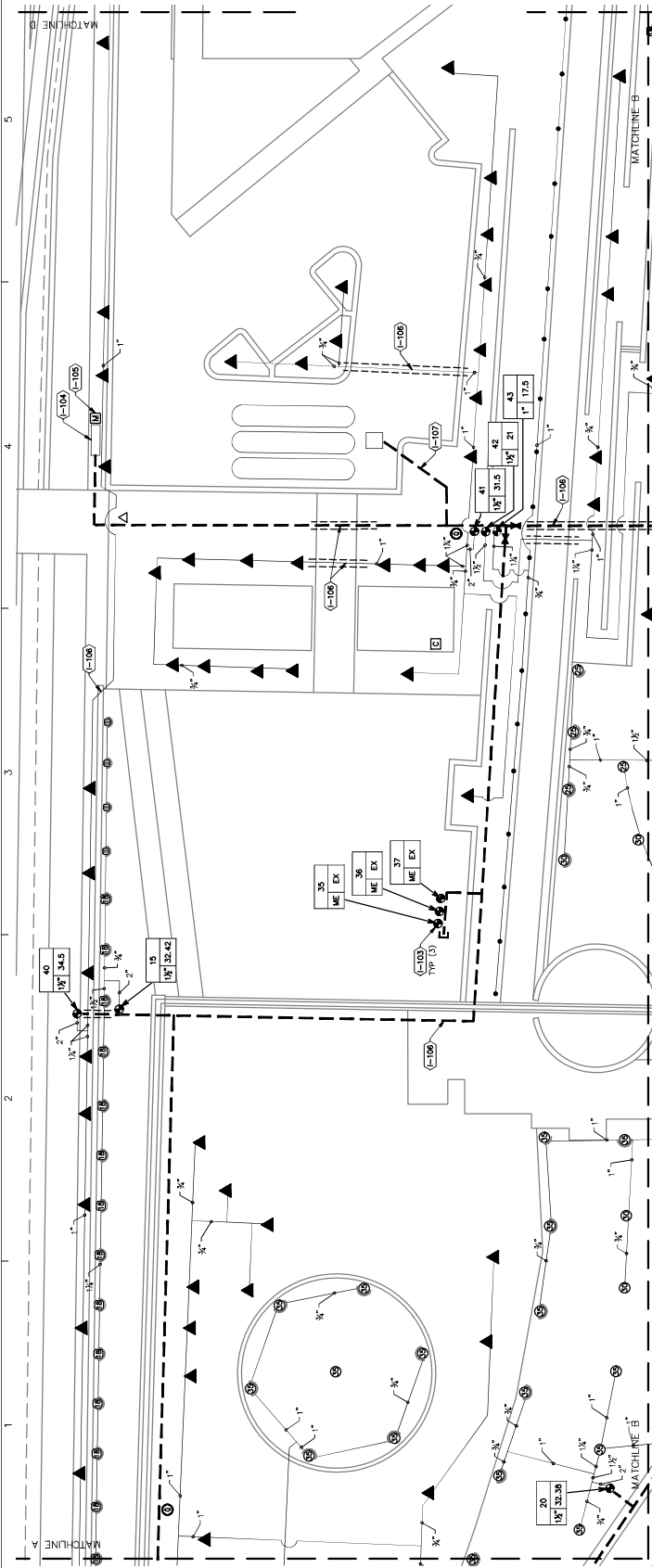

B IRRIGATION PLAN
SCALE: 1"=30'-0"

IRRIGATION LEGEND

- IRRIGATION MAIN LINE, HDPE MANHOLE
- HIGH DENSITY POLYETHYLENE (HDPE) DR-11, SIZE 3", DEPTH OF BURY 28"
- MANHOLE, CONTINUOUS PRESSURE MAIN, 18" FOR NON-CONTINUOUS PRESSURE
- IRRIGATION LATERAL UNDRIP SCHEDULE 40
- 50# 40 BELL END, SOLVENT WELD PVC, SIZE AS SHOWN ON PLAN, DEPTH OF BURY 18"
- LATERAL PIPE CONVEYING LESS THAN 5 GPM SHALL BE 3/4"
- PIPE SLEEVES FOR MAIN LINE AND LATERAL PIPING, CLASS 200 PVC (SFR-2), BELL END, SOLVENT WELD PVC, 2" SIZE, LARGER THAN PVC BEING SECTORED
- PIPE SLEEVE FOR 2" WIRE IRRIGATION CONTROL CABLE, 1-1/2" CLASS 200, UNDRIP
- AIR RELEASE VALVE ASSEMBLY
- EXTING DISCHARGER CHECKING INTO CONTROLLER LOCATION IN EXISTING MISCELLANEOUS ROOM
- WATER METER, EXISTING
- AIR RELEASE VALVE ASSEMBLY, 1" AIR RELEASE VALVE LOCATIONS ARE SHOWN SCHEMATICALLY AT HIGH POINTS IN ELEVATION, VERIFY FINAL LOCATION OF AIR RELEASE VALVE TO INSURE THEY ARE AT ACTUAL HIGH POINTS. SEE DETAIL 3/1501
- PRESSURE COMPENSATING BUBBLER ASSEMBLIES, RAIN BIRD 1400 SERIES WITH CHECK VALVE, REFER TO DETAILS 5/1501 & 6/1501. INSTALL AS FOLLOWS:
MODEL NO. PSI FLOW (GPM)
1402 30 0.5
1403 30 0.5

IRRIGATION KEYED NOTES

- 1-101 RAINBIRD SURFING SYSTEMS ADDRESS RAINBIRD TRACK. INSTALL MAINLINE WITH END CAP AND PROVIDE 6" APPROXIMATE. CONTRACTOR SHALL VERIFY LOCATION AND DEPTH.
- 1-102 ROTOR ON EXTENDED RISER. INSTALL PER DETAIL.
- 1-103 REPLACE EXISTING AUTOMATIC VALVE ASSEMBLY AND TIE-IN TO EXISTING LATERAL SYSTEM FOR LAWN AREA. MATCH EXISTING VALVE SIZE.
- 1-104 EXISTING BACKFLOW PREVENTER ASSEMBLY TO REMAIN.
- 1-105 EXISTING METER TO REMAIN.
- 1-106 INSTALL PIPE, SLEEVE, OR CONTROLLER WIRE BY REFER TO DETAILS 5/1501 & 6/1501. VERIFY LOCATION AND DEPTH.
- 1-107 CONTRACTOR SHALL COORDINATE CONNECTION TO EXISTING LINE WITH OTHER CONTRACTOR PERFORMING THAT WORK.

ROTOR SPRINKLER ASSEMBLIES, RAIN BIRD 5009 MATCHED PRECIPITATION SERIES, 6" POP-UP, AS FOLLOWS:

MODEL NO.	RADIUS	PSI	FLOW (GPM)	PRECIP. RATE (IN./HR.)
RB-5000-MPR-25 25	45	1.00	1.96	3.82
RB-5000-MPR-30 30	45	1.40	2.96	5.78
RB-5000-MPR-35 35	45	1.92	3.81	7.58

POP-UP ROTOR SPRINKLER ASSEMBLIES, RAIN BIRD R-WAN ADJUSTABLE SERIES, 12" POP-UP, AS FOLLOWS:

MODEL NO.	RADIUS	PSI	FLOW (GPM)	PRECIP. RATE (IN./HR.)
R-WAN-14	8'-14"	45	0.32	0.63
R-WAN-18	13'-18"	45	0.50	1.01
R-WAN-24	17'-24"	45	0.84	1.68

A IRRIGATION PLAN
SCALE: 1"=30'-0"



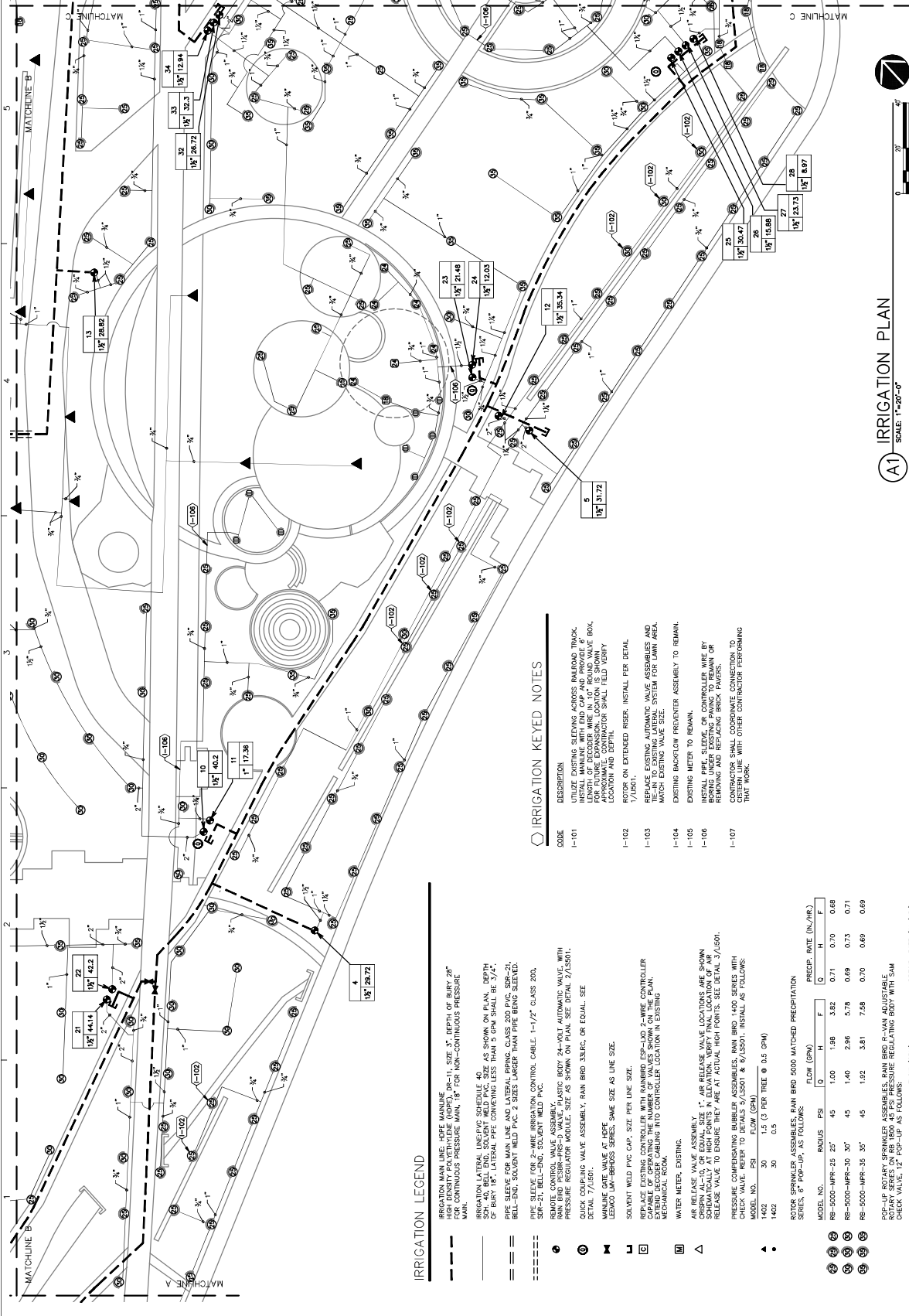

IRRIGATION LEGEND

- IRRIGATION MAIN LINE, HDPE MAINLINE
- HIGH DENSITY POLYETHYLENE (HDPE), DR=11, SIZE 3", DEPTH OF BURY 28" FOR NON-CONTINUOUS PRESSURE MAIN, 18" FOR CONTINUOUS PRESSURE MAIN.
- IRRIGATION LATERAL, LING-PVC SCHEDULE 40
- SDR 40, BELL END, SOLVENT WELD PVC SIZE AS SHOWN ON PLAN. DEPTH OF BURY 18" - LATERAL PIPE COVERING LESS THAN 3" GPM SHALL BE 3/4".
- BELL END, SOLVENT WELD PVC, 2" SIZES LARGER THAN PIPE BEING SIZED.
- SFR-21, BELL-END, SOLVENT WELD PVC.
- SFR-21, BELL-END, SOLVENT WELD PVC.
- REMOTE CONTROL VALVE ASSEMBLY.
- RAIN BRD PRESS-RR-3 VALVE, PLASTIC BODY 24-VOLT AUTOMATIC VALVE, WITH PRESSURE REGULATING MODULE, SIZE AS SHOWN ON PLAN. SEE DETAIL 2/150/1.
- CLICK OPERATOR VALVE ASSEMBLY, RAIN BRD 33KX, OR EQUAL, SEE DETAIL 2/150/1.
- MAINLINE GATE VALVE AT BORE
- LEMCO 1/4"-BRASS SERIES; SAME SIZE AS LINE SIZE.
- SOLVENT WELD PVC CAP, SIZE PER LINE SIZE.
- PERMITS VALVE ASSEMBLY.
- PERMITS VALVE ASSEMBLY, PERMITS VALVE ASSEMBLY, CAPABLE OF OPERATING THE NUMBER OF VALVES SHOWN ON THE PLAN. CAPABLE OF OPERATING THE NUMBER OF VALVES SHOWN ON THE PLAN.
- WATER METERS, EXISTING.
- △ AIR RELEASE VALVE ASSEMBLY.
- △ AIR RELEASE VALVE LOCATIONS ARE SHOWN SCHEMATICALLY AT HIGH POINTS IN ELEVATION. VERIFY FINAL LOCATION OF AIR RELEASE VALVE TO ENSURE THEY ARE AT ACTUAL HIGH POINTS. SEE DETAIL 2/150/1.
- △ PRESSURE COMPENSATING BUBBLER ASSEMBLIES, MAIN BRD 1400 SERIES WITH CHECK VALVE, REFER TO DETAILS 5/130/1 & 6/130/1. INSTALL AS FOLLOWS:
1402 30 1.5 (3 PER TREE @ 0.5 GPM)
1402 30 0.5

IRRIGATION KEYED NOTES

- 1-101 DESCRIPTION: UTILIZE EXISTING SLEEVING ACROSS RAILROAD TRACK. INSTALL PERMITS VALVE ASSEMBLY WITH 1" AIR RELEASE VALVE. LENGTH OF DISCHARGE PIPE N.E. OF ROUND VALVE BOX FOR FUTURE EXPANSION. LOCATION IS SHOWN ON PLAN. LOCATION AND DEPTH. FIELD VERIFY LOCATION AND DEPTH.
- 1-102 ROTOR ON EXTENDED RISER, INSTALL PER DETAIL 1/150/1.
- 1-103 REPLACE EXISTING AUTOMATIC VALVE ASSEMBLIES AND MAINLINE GATE VALVE WITH PERMITS VALVE ASSEMBLY. MATCH EXISTING VALVE SIZE.
- 1-104 EXISTING BACKFLOW PREVENTER ASSEMBLY TO REMAIN. EXISTING METERS TO REMAIN.
- 1-105 INSTALL PERMITS VALVE ASSEMBLY WITH 1" AIR RELEASE VALVE. BORE UNDER EXISTING PAVING TO REMAIN OR REMOVE AND REPLACING BRICK PAVING.
- 1-107 CONTRACTOR SHALL COORDINATE CONNECTION TO EXISTING MAINLINE WITH OTHER CONTRACTOR PERFORMING THAT WORK.

ROTOR SPRINKLER ASSEMBLIES, RAIN BRD 5000 MATCHED PRECIPITATION SERIES, 4" POP-UP, AS FOLLOWS:

MODEL NO.	RADIUS	PSI	FLOW (GPM)			PRECIP. RATE (IN./HR.)		
			Q	H	F	G	H	F
RE-5000-MPR-25 25'	45	1.00	1.98	3.82	0.71	0.70	0.68	
RE-5000-MPR-30 30'	45	1.40	2.96	5.78	0.69	0.73	0.71	
RE-5000-MPR-35 35'	45	1.92	3.51	7.45	0.70	0.69	0.69	

POP-UP ROTARY SPRINKLER ASSEMBLIES, MAIN BRD R-VAN ADJUSTABLE SERIES, 4" POP-UP, AS FOLLOWS:

MODEL NO.	RADIUS	PSI	FLOW (GPM)			PRECIP. RATE (IN./HR.)		
			Q	H	F	G	H	F
R-VAN-14 8'-14"	45	0.32	0.63	0.94	0.70	0.70	0.70	
R-VAN-18 13'-18"	45	0.50	1.01	1.51	0.73	0.73	0.73	
R-VAN-24 17'-24"	45	0.84	1.68	2.52	0.71	0.71	0.71	



A1 SCALE: 1"=40'-0"

CONSULTANTS

**SANTA FE RAILYARD
PARK IRRIGATION
RENOVATION PLAN**

OCTOBER 1, 2024

SUBMITTAL: 100% FOR CONSTRUCTION

NO. DATE DESCRIPTION

PROJECT NO. 22075

CAD DWG FILE:

DESIGNED BY: GMM/MW

DRAWN BY: MMW

CHECKED BY: GM

SHEET TITLE

**IRRIGATION
PLAN**

DRAWING SHEET
LI104

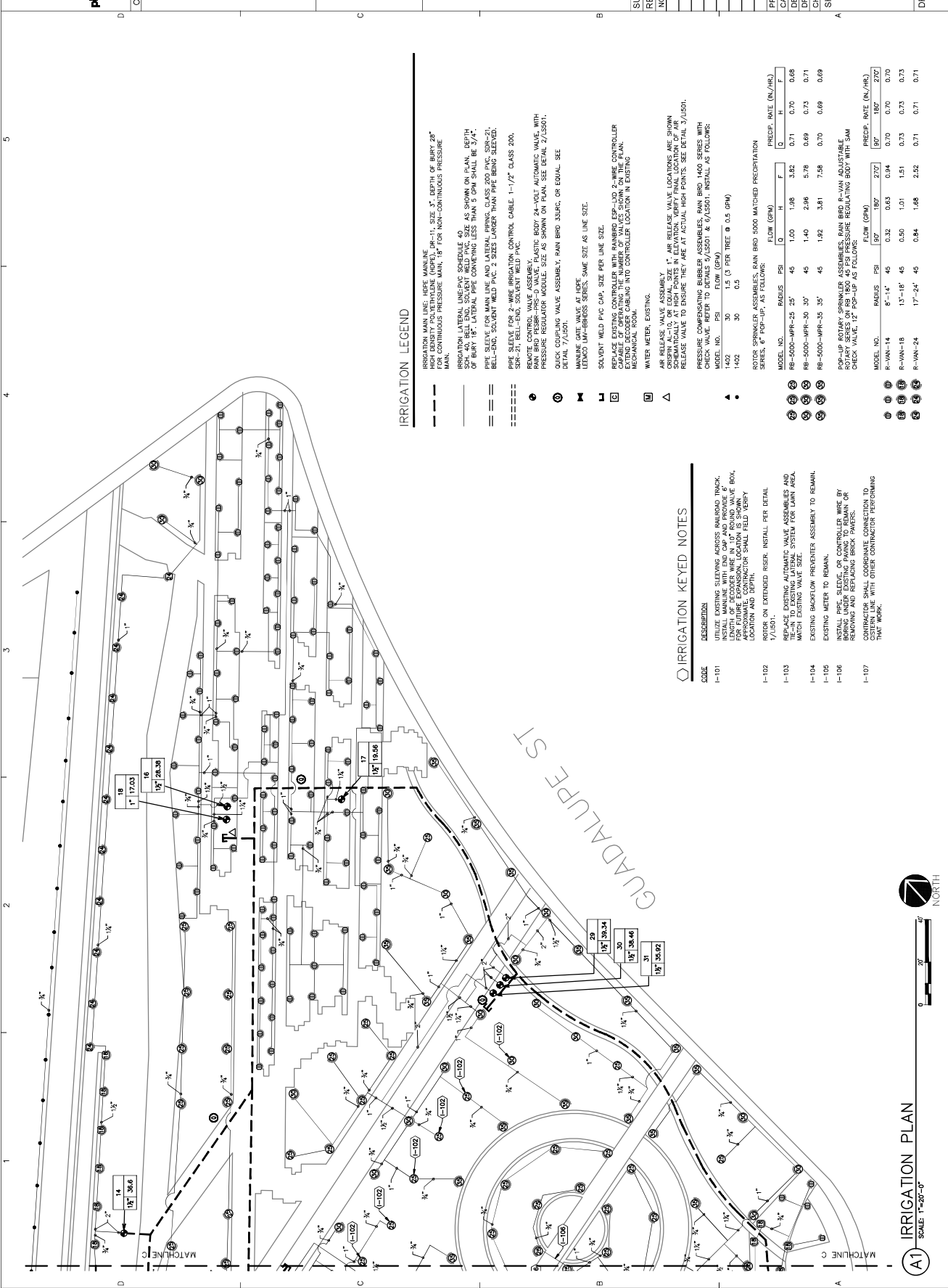

IRRIGATION LEGEND

- IRRIGATION MAIN LINE: HDPE MAINLINE
- HIGH DENSITY POLYETHYLENE (HDPE), DR-11, SIZE 3", DEPTH OF BURY 28" MINIMUM, CONTINUOUS PRESSURE MAIN, 18' FOR NON-CONTINUOUS PRESSURE MAIN.
- IRRIGATION LATERAL LINE: PVC SCHEDULE 40
- SCH. 40, BELL END, SOLVENT WELD PVC SIZE AS SHOWN ON PLAN. DEPTH OF BURY 18" LATERAL PIPE CONTAINING LESS THAN 8" DI. SHALL BE 3'-4".
- BELL END, SOLVENT WELD PVC, 2 SIZES LARGER THAN PIPE BEING SERVED.
- SPR-21, BELL-END, SOLVENT WELD PVC
- SPR-21, BELL-END, SOLVENT WELD PVC
- REMOTE CONTROL VALVE ASSEMBLY
- MAIN BRD PRESS-PRS-D VALVE, PLASTIC BODY 24-VOLT AUTOMATIC VALVE, WITH PRESSURE REGULATOR MODEL SIZE AS SHOWN ON PLAN. SEE DETAIL 2/LS01.
- DETAIL 2/LS01
- VALVE ASSEMBLY, MAIN BRD 33KIC, OR EQUAL, SEE DETAIL 2/LS01
- MANLINE GATE VALVE AT HOPE
- LEMCO LW-BRHS SERIES, SAME SIZE AS LINE SIZE.
- SOLVENT WELD PVC CAP, SIZE PER LINE SIZE.
- REPLACE EXISTING CONTROLLER WITH RAINBOW ESP-UP 8-WIRE CONTROLLER CAPABLE OF OPERATING THE NUMBER OF VALVES SHOWN ON THE PLAN. MECHANICAL ROOM.
- WATER METER, EXISTING.
- WATER METER, EXISTING.
- AIR RELEASE VALVE, EXISTING
- OPEN AIR-10, OR EQUAL SIZE 1". AIR RELEASE VALVE LOCATIONS ARE SHOWN SCHEMATICALLY AT HIGH POINTS IN ELEVATION. VERIFY FINAL LOCATION OF AIR RELEASE VALVE DEPENDING ON ACTUAL HIGH POINTS. SEE DETAIL 2/LS01.
- PRESSURE COMPENSATING BUBBLER ASSEMBLIES, MAIN BRD 1400 SERIES WITH MODEL NO. 30 FLOW (GPM) 1.5 (3 PER TREE @ 0.5 GPM)
- 1402 30 1.5 (3 PER TREE @ 0.5 GPM)
- 1402 30 0.5
- ROTARY SPRINKLER ASSEMBLIES, MAIN BRD 5000 MATCHED PRECIPITATION SIZES, 8" POP-UP, AS FOLLOWS:
- MODEL NO. RADIUS PSI Q H F PRECP. RATE (IN./HR.)
- RB-5000-MPR-25 25' 45 1.00 1.98 3.82 0.71 1.80' 2700
- RB-5000-MPR-30 30' 45 1.40 2.96 5.78 0.69 0.73 0.71
- RB-5000-MPR-35 35' 45 1.92 3.81 7.58 0.70 0.69 0.69
- POP-UP ROTARY SPRINKLER ASSEMBLIES, MAIN BRD R-VAN ADJUSTABLE PRECIPITATION SIZES, 8" POP-UP, AS FOLLOWS:
- CHECK VALVE, 2" POP-UP, AS FOLLOWS:
- MODEL NO. RADIUS PSI FLOW (GPM) PRECP. RATE (IN./HR.)
- R-VAN-14 8'-14" 45 0.32 0.63 0.84 0.70 0.70 0.70
- R-VAN-18 13'-18" 45 0.50 1.01 1.51 0.73 0.73 0.73
- R-VAN-24 17'-24" 45 0.84 1.68 2.52 0.71 0.71 0.71

IRRIGATION KEYED NOTES

- I-101 UTILIZE EXISTING SLEEVES ACROSS RAILROAD TRACK. INSTALL MAINLINE WITH END CAP AND PROVIDE 6" MINIMUM CLEARANCE TO EXISTING TRACK. APPROXIMATE CONTRACTOR SHALL FIELD VERIFY PIPES ON EXTENDED RISER. INSTALL PER DETAIL 1/LS01.
- I-102 REPLACE EXISTING AUTOMATIC VALVE ASSEMBLIES AND TIE-IN TO EXISTING LATERAL SYSTEM FOR LAWN AREA, WHICH EXISTING VALVE SIZE.
- I-104 EXISTING BACKFLOW PREVENTER ASSEMBLY TO REMAIN.
- I-105 INSTALL PFC, SLEWIC, OR CONTROLLER WIRE BY CONTRACTOR. VERIFY SIZE AND LOCATION OF EXISTING AND REPLACING BRICK PAVERS.
- I-107 CONTRACTOR SHALL COORDINATE CONNECTION TO GUTTER LINE WITH OTHER CONTRACTOR PERFORMING THIS WORK.



(A) IRRIGATION PLAN
SCALE: 1"=20'-0"

CONSULTANTS



**SANTA FE RAILYARD
PARK IRRIGATION
RENOVATION PLAN**

OCTOBER 1, 2024

SUBMITTAL: 100% FOR CONSTRUCTION

DESIGNED BY: GMM/MW

DRAWN BY: MW

CHECKED BY: GM

SHEET TITLE

**IRRIGATION
DETAILS**

DRAWING SHEET

LI501

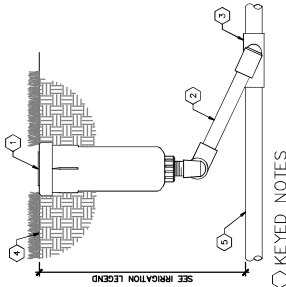

4 SPRINKLER ASSEMBLY
NOT TO SCALE

- KEYED NOTES**
1. SPRINKLER BODY - SEE IRRIGATION LEGEND
 2. 2-1/2" DIAMETER GALVANIZED STEEL PIPE
 3. 3/4" SOLVENT WELD ELBOW
 4. 3/4" SOLVENT WELD ELBOW
 5. LATERAL PIPING

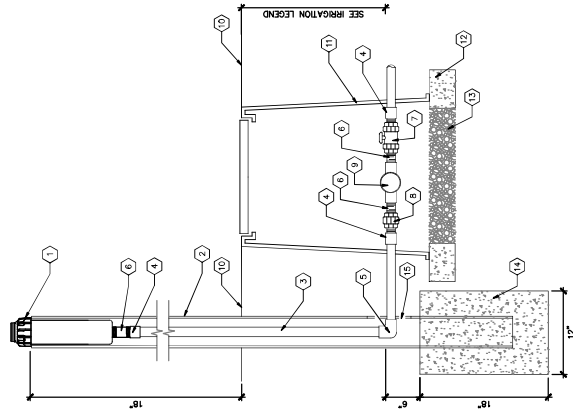

1 ROTOR ON EXTENDED RISER
NOT TO SCALE

- KEYED NOTES**
1. SPRINKLER BODY, SEE IRRIGATION LEGEND
 2. 2-1/2" DIAMETER GALVANIZED STEEL PIPE
 3. 3/4" SOLVENT WELD ELBOW
 4. 3/4" SOLVENT WELD ELBOW
 5. 3/4" SCH. 80 NIPPLE
 6. SPARE UNION
 7. KING DRAIN
 8. KING DRAIN
 9. KING DRAIN
 10. FINISH GRADE
 11. CARSON 1418 VALVE BOX W/ BOLT DOWN FLUSH
 12. SOLID OMB BLOCK - FOUR PER BOX
 13. 6" DEPTH OF 1" CRUSHED GRAVEL
 14. 4" X 2" OPENING IN STEEL PIPE
 15. 4" X 2" OPENING IN STEEL PIPE

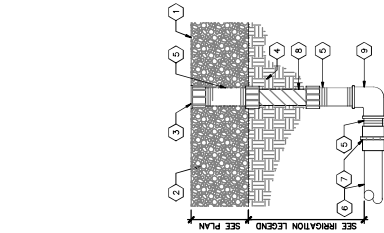

5 BUBBLER ASSEMBLY
NOT TO SCALE

- KEYED NOTES**
1. FINISH GRADE
 2. MATCH COMPENSATING BUBBLER - SEE IRRIGATION LEGEND
 3. IRRIGATION LEGEND, TOP OF BUBBLER SHALL BE COMPACTED SUBGRADE
 4. 1/2" SCH. 80 PVC THREADED NIPPLE, LENGTH 12"
 5. 3/4" LATERAL PIPING, PVC FEMALE ADAPTER
 6. 1/2" X 6" FLEX NIPPLE
 7. 1/2" SCH. 40 PVC THREADED ELBOW
 8. 1/2" SCH. 40 PVC THREADED ELBOW
 9. 1/2" SCH. 40 PVC THREADED ELBOW

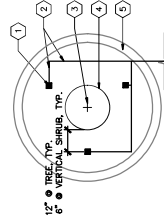

6 THREE-BUBBLER LAYOUT
NOT TO SCALE

- KEYED NOTES**
1. BUBBLER ASSEMBLY - SEE IRRIGATION LEGEND, INSTALL PER DETAIL C4/L1501
 2. CENTER OF THE PIPING
 3. EDGE OF ROOF BALL
 4. CENTER OF THE PIPING
 5. EXISTING DETAIL - SEE PLANNING DETAILS

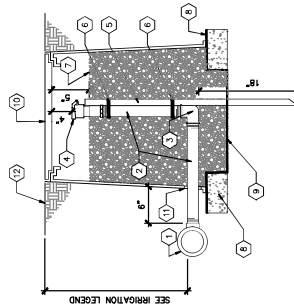

7 QUICK COUPLER VALVE
NOT TO SCALE

- KEYED NOTES**
1. 1" VALVE, 1" WASHED GRAVEL
 2. 1" SCH. 80 PVC NIPPLE, LENGTH AS REQUIRED
 3. 1" SCH. 80 PVC NIPPLE, LENGTH AS REQUIRED
 4. 1" SCH. 80 PVC THREADED ELBOW
 5. 1" SCH. 80 PVC THREADED ELBOW
 6. 1" SCH. 80 PVC THREADED ELBOW
 7. 1" SCH. 80 PVC THREADED ELBOW
 8. 1" SCH. 80 PVC THREADED ELBOW
 9. 1" SCH. 80 PVC THREADED ELBOW
 10. 1" SCH. 80 PVC THREADED ELBOW
 11. 1" SCH. 80 PVC THREADED ELBOW
 12. FINISH GRADE
- GENERAL NOTES**
1. MINIMUM CLEARANCE BETWEEN VALVE BOX AND INSIST AS SET IN BOX
 2. PROVIDE ONE (1) VALVE KEY AND ONE (1) LOCKING COVER SET TO THE OWNER, PER QUICK COUPLER

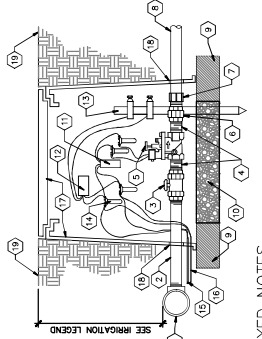

2 REMOTE CONTROL VALVE ASSEMBLY - TWO-WIRE
NOT TO SCALE

- KEYED NOTES**
1. SERVICE TEE AT MAINLINE
 2. SCH. 80 PVC NIPPLE, LENGTH AS REQUIRED
 3. SCH. 80 PVC NIPPLE, LENGTH AS REQUIRED
 4. SCH. 80 PVC NIPPLE, 3" LENGTH
 5. IRRIGATION LEGEND
 6. 1" SCH. 80 PVC THREADED ELBOW
 7. 1" SCH. 80 PVC THREADED ELBOW
 8. 1" SCH. 80 PVC THREADED ELBOW
 9. 1" SCH. 80 PVC THREADED ELBOW
 10. 1" SCH. 80 PVC THREADED ELBOW
 11. FIELD DECODER
 12. IN-LINE SURGE PROTECTOR, AS REQUIRED
 13. BY MANUFACTURER, 1/2" DIAM OR LESS AT LOCATION, AS REQUIRED BY IRRIGATION LEGEND
 14. WATERPROOF WIRE CONNECTOR
 15. 1" SCH. 80 PVC THREADED ELBOW
 16. 1" SCH. 80 PVC THREADED ELBOW
 17. 1" X 30" HEAVY-DUTY VALVE BOX WITH 1" DIAMETER WASHED GRAVEL
 18. 1" X 30" HEAVY-DUTY VALVE BOX WITH 1" DIAMETER WASHED GRAVEL
 19. FINISH GRADE
- GENERAL NOTES**
1. CONTRACTOR SHALL INSTALL ONE AUTOMATIC VALVE ASSEMBLY PER VALVE BOX.

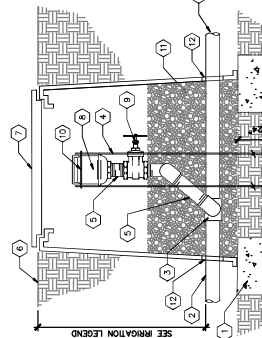

3 AIR RELIEF VALVE
NOT TO SCALE

- KEYED NOTES**
1. SOLID OMB BLOCK, FOUR PER BOX
 2. SCH. 40 PVC TEE
 3. SCH. 40 PVC TEE
 4. 1/2" DIAMETER REBAR
 5. 1/2" DIAMETER REBAR
 6. 1/2" DIAMETER REBAR
 7. 17" X 30" HEAVY-DUTY VALVE BOX WITH 1" DIAMETER WASHED GRAVEL
 8. 17" X 30" HEAVY-DUTY VALVE BOX WITH 1" DIAMETER WASHED GRAVEL
 9. 17" X 30" HEAVY-DUTY VALVE BOX WITH 1" DIAMETER WASHED GRAVEL
 10. 17" X 30" HEAVY-DUTY VALVE BOX WITH 1" DIAMETER WASHED GRAVEL
 11. 1" DIAMETER WASHED GRAVEL
 12. 1/2" LARGER THAN PIPE
 13. 1/2" LARGER THAN PIPE
 14. 1/2" LARGER THAN PIPE
 15. 1/2" LARGER THAN PIPE
 16. 1/2" LARGER THAN PIPE
 17. 1/2" LARGER THAN PIPE
 18. 1/2" LARGER THAN PIPE
 19. 1/2" LARGER THAN PIPE
 20. 1/2" LARGER THAN PIPE
 21. 1/2" LARGER THAN PIPE
 22. 1/2" LARGER THAN PIPE
 23. 1/2" LARGER THAN PIPE
 24. 1/2" LARGER THAN PIPE
 25. 1/2" LARGER THAN PIPE
 26. 1/2" LARGER THAN PIPE
 27. 1/2" LARGER THAN PIPE
 28. 1/2" LARGER THAN PIPE
 29. 1/2" LARGER THAN PIPE
 30. 1/2" LARGER THAN PIPE
 31. 1/2" LARGER THAN PIPE
 32. 1/2" LARGER THAN PIPE
 33. 1/2" LARGER THAN PIPE
 34. 1/2" LARGER THAN PIPE
 35. 1/2" LARGER THAN PIPE
 36. 1/2" LARGER THAN PIPE
 37. 1/2" LARGER THAN PIPE
 38. 1/2" LARGER THAN PIPE
 39. 1/2" LARGER THAN PIPE
 40. 1/2" LARGER THAN PIPE
 41. 1/2" LARGER THAN PIPE
 42. 1/2" LARGER THAN PIPE
 43. 1/2" LARGER THAN PIPE
 44. 1/2" LARGER THAN PIPE
 45. 1/2" LARGER THAN PIPE
 46. 1/2" LARGER THAN PIPE
 47. 1/2" LARGER THAN PIPE
 48. 1/2" LARGER THAN PIPE
 49. 1/2" LARGER THAN PIPE
 50. 1/2" LARGER THAN PIPE
 51. 1/2" LARGER THAN PIPE
 52. 1/2" LARGER THAN PIPE
 53. 1/2" LARGER THAN PIPE
 54. 1/2" LARGER THAN PIPE
 55. 1/2" LARGER THAN PIPE
 56. 1/2" LARGER THAN PIPE
 57. 1/2" LARGER THAN PIPE
 58. 1/2" LARGER THAN PIPE
 59. 1/2" LARGER THAN PIPE
 60. 1/2" LARGER THAN PIPE
 61. 1/2" LARGER THAN PIPE
 62. 1/2" LARGER THAN PIPE
 63. 1/2" LARGER THAN PIPE
 64. 1/2" LARGER THAN PIPE
 65. 1/2" LARGER THAN PIPE
 66. 1/2" LARGER THAN PIPE
 67. 1/2" LARGER THAN PIPE
 68. 1/2" LARGER THAN PIPE
 69. 1/2" LARGER THAN PIPE
 70. 1/2" LARGER THAN PIPE
 71. 1/2" LARGER THAN PIPE
 72. 1/2" LARGER THAN PIPE
 73. 1/2" LARGER THAN PIPE
 74. 1/2" LARGER THAN PIPE
 75. 1/2" LARGER THAN PIPE
 76. 1/2" LARGER THAN PIPE
 77. 1/2" LARGER THAN PIPE
 78. 1/2" LARGER THAN PIPE
 79. 1/2" LARGER THAN PIPE
 80. 1/2" LARGER THAN PIPE
 81. 1/2" LARGER THAN PIPE
 82. 1/2" LARGER THAN PIPE
 83. 1/2" LARGER THAN PIPE
 84. 1/2" LARGER THAN PIPE
 85. 1/2" LARGER THAN PIPE
 86. 1/2" LARGER THAN PIPE
 87. 1/2" LARGER THAN PIPE
 88. 1/2" LARGER THAN PIPE
 89. 1/2" LARGER THAN PIPE
 90. 1/2" LARGER THAN PIPE
 91. 1/2" LARGER THAN PIPE
 92. 1/2" LARGER THAN PIPE
 93. 1/2" LARGER THAN PIPE
 94. 1/2" LARGER THAN PIPE
 95. 1/2" LARGER THAN PIPE
 96. 1/2" LARGER THAN PIPE
 97. 1/2" LARGER THAN PIPE
 98. 1/2" LARGER THAN PIPE
 99. 1/2" LARGER THAN PIPE
 100. 1/2" LARGER THAN PIPE
- GENERAL NOTES**
1. WASHED GRAVEL SHALL BE INSTALLED FLUSH WITH BOTTOM OF GATE VALVE.



**State of New Mexico
General Services Department
Purchasing Division**

Statewide Price Agreement Amendment

Awarded Vendor:
5 Vendors

Number: 30-00000-23-00091

Amendment No.: One

Term: July 21, 2023 – July 20, 2025

Ship To:
All State of New Mexico agencies, commissions, institutions, political subdivisions and local public bodies allowed by law.

Procurement Specialist: Clarke J. Fountain

Telephone No.: (505) 629-2964

Invoice:
As Requested at Time of Order

Email: ClarkeJ.Fountain@gsd.nm.gov

Title: Landscaping Statewide

This amendment is to be attached to the respective Price Agreement and become a part thereof.

In accordance with Price Agreement provisions, and by mutual agreement of all parties, this Price Agreement is extended from July 21, 2024 to July 20, 2025 at the same price, terms and conditions.

Except as modified by this amendment, the provisions of the Price Agreement shall remain in full force and effect.

Accepted for the State of New Mexico

Natalie Martinez

Date: 6/10/2024

Dorothy Mendonca
New Mexico State Purchasing Agent

x This Agreement was signed on behalf of the State Purchasing Agent

Certificate Of Completion

Envelope Id: E0965E63FD604B81BBBF84A0AA01ADE1	Status: Completed
Subject: DocuSign: 30-00000-23-00091 Landscaping A001	
Source Envelope:	
Document Pages: 1	Signatures: 1
Certificate Pages: 2	Initials: 2
AutoNav: Enabled	Envelope Originator:
Envelope Stamping: Enabled	Clarke Fountain
Time Zone: (UTC-07:00) Mountain Time (US & Canada)	1100 S Saint Francis Dr
	Santa Fe, NM 87502
	ClarkeJ.Fountain@gsd.nm.gov
	IP Address: 164.64.62.10

Record Tracking

Status: Original	Holder: Clarke Fountain	Location: DocuSign
6/10/2024 10:06:28 AM	ClarkeJ.Fountain@gsd.nm.gov	
Security Appliance Status: Connected	Pool: StateLocal	
Storage Appliance Status: Connected	Pool: GSD	Location: DocuSign

Signer Events

Signature	Timestamp
Tami Concha tami.concha@gsd.nm.gov Const. Supervisor New Mexico General Services, State Purchasing Division Security Level: Email, Account Authentication (None)	Sent: 6/10/2024 10:08:32 AM Viewed: 6/10/2024 10:17:53 AM Signed: 6/10/2024 10:18:05 AM
<i>JC</i>	
Signature Adoption: Pre-selected Style Using IP Address: 164.64.62.10	

Electronic Record and Signature Disclosure:
Not Offered via DocuSign

Clarke Fountain clarkej.fountain@gsd.nm.gov Procurement Specialist New Mexico General Services Security Level: Email, Account Authentication (None)	<i>CF</i>	Sent: 6/10/2024 10:18:06 AM Viewed: 6/10/2024 10:38:19 AM Signed: 6/10/2024 10:38:29 AM
Signature Adoption: Pre-selected Style Using IP Address: 164.64.62.10		

Electronic Record and Signature Disclosure:
Not Offered via DocuSign

Natalie Martinez natalie.martinez1@gsd.nm.gov Deputy Director New Mexico General Services Signing Group: 35000 - State Purchasing Agent Security Level: Email, Account Authentication (None)	<i>Natalie Martinez</i>	Sent: 6/10/2024 10:38:30 AM Viewed: 6/10/2024 12:17:42 PM Signed: 6/10/2024 12:22:54 PM
Signature Adoption: Pre-selected Style Using IP Address: 164.64.62.10		

Electronic Record and Signature Disclosure:
Not Offered via DocuSign

In Person Signer Events

Signature

Timestamp

Editor Delivery Events

Status

Timestamp

Agent Delivery Events

Status

Timestamp

Intermediary Delivery Events

Status

Timestamp

Certified Delivery Events

Status

Timestamp

Carbon Copy Events	Status	Timestamp
---------------------------	---------------	------------------

Witness Events	Signature	Timestamp
-----------------------	------------------	------------------

Notary Events	Signature	Timestamp
----------------------	------------------	------------------

Envelope Summary Events	Status	Timestamps
--------------------------------	---------------	-------------------

Envelope Sent	Hashed/Encrypted	6/10/2024 10:08:32 AM
Certified Delivered	Security Checked	6/10/2024 12:17:42 PM
Signing Complete	Security Checked	6/10/2024 12:22:54 PM
Completed	Security Checked	6/10/2024 12:22:54 PM

Payment Events	Status	Timestamps
-----------------------	---------------	-------------------



**State of New Mexico
General Services Department**

Statewide Price Agreement

Awarded Vendor:
5 Vendors

Price Agreement Number: **30-00000-23-00091**

Payment Terms: **Net 30**

F.O.B.: **Destination**

Delivery: **See Page 6**

Ship To:
All State of New Mexico agencies, commissions, institutions, political subdivisions and local public bodies allowed by law.

Procurement Specialist: **James Ortega**

Telephone No.: **(505) 795-2516**

Email: **James.Ortega@gsd.nm.gov**

Invoice:
As Requested at Time of Order

Title: Landscaping Statewide

Term: July 21, 2023 thru July 20, 2024

This Statewide Price Agreement is made subject to the “terms and conditions” as indicated on subsequent pages.

Accepted for the State of New Mexico

Dorothy Mendonca
Dorothy Mendonca
New Mexico State Purchasing Agent

Date: 7/21/2023

ms *lk*

State of New Mexico
General Services Department
Purchasing Division
Statewide Price Agreement #: 30-00000-23-00091

Page-2

Terms and Conditions
(Unless otherwise specified)

1. **General:** When the State Purchasing Agent or his/her designee issues a purchase document in response to the Vendor's bid, a binding contract is created.
2. **Variation in Quantity:** No variation in the quantity of any item called for by this order will be accepted unless such variation has been caused by conditions of loading, shipping, packing or allowances in manufacturing process and then only to the extent, if any, specified in this order.
3. **Assignment:**
 - a. Neither the order, nor any interest therein, nor any claim thereunder, shall be assigned or transferred by the Vendor, except as set forth in Subparagraph 3b or as expressly authorized in writing by the State Purchasing Agent or his/her designee. No such assignment or transfer shall relieve the Vendor from the obligations and liabilities under this order.
 - b. Vendor agrees that any and all claims for overcharge resulting from antitrust violations which are borne by the State as to goods, services, and materials purchased in connection with this bid are hereby assigned to the State.
4. **State Furnished Property:** State furnished property shall be returned to the State upon request in the same condition as received except for ordinary wear, tear and modifications ordered hereunder.
5. **Discounts:** Prompt payment discounts will not be considered in computing the low bid.
6. **Inspection:** Final inspection and acceptance will be made at the destination. Supplies rejected at the destination for nonconformance with specifications shall be removed at the Vendor's risk and expense, promptly after notice of rejection.
7. **Inspection of Plant:** The State Purchasing Agent or his/her designee may inspect, at any reasonable time, the part of the Contractor's, or any subcontractor's plant or place of business, which is related to the performance of this contract.
8. **Commercial Warranty:** The Vendor agrees that the supplies or services furnished under this order shall be covered by the most favorable commercial warranties the Vendor gives for such to any customer for such supplies or services. The rights and remedies provided herein shall extend to the State and are in addition to and do not limit any rights afforded to the State by any other clause of this order. **Vendor agrees not to disclaim warranties of fitness for a particular purpose of merchantability.**
9. **Taxes:** The unit price shall exclude all state taxes.
10. **Packing, Shipping and Invoicing:**
 - a. The State's purchasing document number and the Vendor's name, user's name and location shall be shown on each packing and delivery ticket, package, bill of lading and other correspondence in connection with the shipments. The user's count will be accepted by the Vendor as final and conclusive on all shipments not accompanied by a packing ticket.
 - b. The Vendor's invoice shall be submitted duly certified and shall contain the following information: order number, description of supplies or services, quantities, unit price and extended totals. Separate invoices shall be rendered for each and every complete shipment.
 - c. Invoices must be submitted to the using agency and NOT the State Purchasing Agent.
11. **Default:** The State reserves the right to cancel all or any part of this order without cost to the State, if the Vendor fails to meet the provisions of this order and, except as otherwise provided herein, to hold the Vendor liable for any excess cost occasioned by the State due to the Vendor's default. The Vendor shall not be liable for any excess costs if failure to perform the order arises out of causes beyond the control and without the fault or negligence of the Vendor, such causes include but are not restricted to, acts of God or the public enemy, acts of the State or Federal Government, fires, floods, epidemics, quarantine restrictions, strikes, freight embargoes, unusually severe weather and defaults of

State of New Mexico
General Services Department
Purchasing Division
Statewide Price Agreement #: 30-00000-23-00091

Page-3

subcontractors due to any of the above, unless the State shall determine that the supplies or services to be furnished by the subcontractor were obtainable from other sources in sufficient time to permit the Vendor to meet the required delivery scheduled. The rights of the State provided in this paragraph shall not be exclusive and are in addition to any other rights now being provided by law or under this order.

12. **Non-Collusion:** In signing this bid the Vendor certifies he/she has not, either directly or indirectly, entered into action in restraint of free competitive bidding in connection with this offer submitted to the State Purchasing Agent or his/her designee.

13. **Nondiscrimination:** Vendor doing business with the State of New Mexico must be in compliance with the Federal Civil Rights Act of 1964 and Title VII of the Act (Rev. 1979) and the Americans with Disabilities Act of 1990 (Public Law 101-336).

14. **The Procurement Code:** Sections 13-1-28 through 13-1-199 NMSA 1978, imposes civil and criminal penalties for its violation. In addition the New Mexico criminal statutes impose felony penalties for bribes, gratuities and kickbacks.

15. **Items:** All bid items are to be NEW and of most current production, unless otherwise specified.

16. **Payment for Purchases:** Except as otherwise agreed to: late payment charges may be assessed against the user state agency in the amount and under the conditions set forth in Section 13-1-158 NMSA 1978.

17. **Workers' Compensation:** The Contractor agrees to comply with state laws and rules pertaining to Workers' Compensation benefits for its employees. If the Contractor fails to comply with Workers' Compensation Act and applicable rules when required to do so, this Agreement may be terminated by the contracting agency.

18. **Submission of Bid:** Bids must be submitted in a sealed envelope with the bid number and opening date clearly indicated on the bottom left hand side of the front of the envelope. Failure to label bid envelope will necessitate the premature opening of the bid in order to identify the bid number.

19. **Contractor Personnel:** Personnel proposed in the Contractor's written bid to the Procuring Agency are considered material to any work performed under this Price Agreement. Once a Purchase Order or contract has been executed, no changes of personnel will be made by the Contractor without prior written consent of the Procuring Agency. Replacement of any Contractor personnel, if approved, shall be with personnel of equal ability, experience, and qualifications. The Contractor will be responsible for any expenses incurred in familiarizing the replacement personnel to insure their being productive to the project immediately upon receiving assignments. Approval of replacement personnel shall not be unreasonably withheld. The Procuring Agency shall retain the right to request the removal of any of the Contractor's personnel at any time.

20. **Subcontracting:** The Contractor shall not subcontract any portion of the Price Agreement without the prior written approval of the Procuring Agency. No such subcontracting shall relieve the Contractor from its obligations and liabilities under this Price Agreement, nor shall any subcontracting obligate payment from the Agency.

21. **Records and Audit:** The Contractor shall maintain detailed time and expenditure records that indicate the date, time, nature, and cost of services rendered during this Price Agreement's term and effect, and retain them for a period of three (3) years from the date of final payment under this Price Agreement. The records shall be subject to inspection by the Agency, State Purchasing Division, Department of Finance and Administration, and for Information Technology contracts, State Chief Information Officer. The Agency shall have the right to audit billings, both before and after payment. Payment for services under this Price Agreement shall not foreclose the right of the Agency to recover excessive or illegal payments.

22. **Subcontracts:** The foregoing requirements for Contractor Personnel, Subcontracting, and Audit shall be inserted into all subcontracts from the prime contractor to the subcontractor.

New Mexico Employees Health Coverage

A. If Contractor has, or grows to, six (6) or more employees who work, or who are expected to work, an average

State of New Mexico
 General Services Department
 Purchasing Division
 Statewide Price Agreement #: 30-00000-23-00091

Page-4

of at least 20 hours per week over a six (6) month period during the term of the contract, Contractor certifies, by signing this agreement, to have in place, and agrees to maintain for the term of the contract, health insurance for its New Mexico Employees and offer that health insurance to its New Mexico Employees if the expected annual value in the aggregate of any and all contracts between Contractor and the State exceeds \$250,000 dollars.

B. Contractor agrees to maintain a record of the number of its New Mexico Employees who have (a) accepted health insurance; (b) declined health insurance due to other health insurance coverage already in place; or (c) declined health insurance for other reasons. These records are subject to review and audit by a representative of the state.

C. Contractor agrees to advise all of its New Mexico Employees of the availability of State publicly financed health care coverage programs by providing each of its New Mexico Employees with, as a minimum, the following web site link to additional information: <https://bewellnm.com>.

D. For purposes of this Paragraph, the following terms have the following meanings:

- (1) "New Mexico Employee" means any resident of the State of New Mexico employed by Contractor who performs the majority of the employee's work for Contractor within the State of New Mexico, regardless of the location of Contractor's office or offices; and
- (2) "offer" means to make available, without unreasonable restriction, enrollment in one or more health coverage plans and to actively seek and encourage participation in order to achieve the goals of Executive Order 2007-049. This could include State publicly financed public health coverage programs such as *Insure New Mexico!*

Statewide Price Agreement

Article I – Statement of Work

Under the terms and conditions of this Price Agreement all State of New Mexico agencies, commissions, institutions, political subdivisions and local public bodies allowed by law may issue orders for items and/or services described herein. The terms and conditions of this Price Agreement shall form a part of each order issued hereunder.

The items and/or services to be ordered shall be as listed under Article IX - Price Schedule. All orders issued hereunder will bear both an order number and this Price Agreement number. It is understood that no guarantee or warranty is made or implied by the New Mexico State Purchasing Agent, his/her designee or the user that any order for any definite quantity will be issued under this Price Agreement. The Contractor is required to accept the order and furnish the items and/or services in accordance with the articles contained hereunder for the quantity of each order.

Article II – Term

The term of this Price Agreement, for issuance of orders, shall be as indicated in the specifications.

Article III – Specifications

Items and/or services furnished hereunder shall conform to the requirements of specifications and/or drawings applicable to items listed under Article IX-Price Schedule. Orders issued against this schedule will show the applicable Price Agreement item(s), number(s), and price(s); however they may not describe the item(s) fully.

Article IV – Shipping and Billing Instructions

Contractor shall ship in accordance with the following instructions: Shipment shall be made only against specific orders which the user may place with the Contractor during the term; The Contractor shall enclose a packing list with each shipment listing the order number, price agreement number and the commercial parts number (if any) for each item; Delivery shall be made as indicated on page 1. If vendor is unable to meet stated delivery the State Purchasing Agent or his/her designee must be notified.

Article V – Termination

The Agency may terminate this Agreement for convenience or cause. The Contractor may only terminate this Agreement based upon the Agency's uncured, material breach of this Agreement. Contractor shall give Agency written notice of termination at least thirty (30) days prior to the intended date of termination, which notice shall (i) identify all the Agency's material breaches of this Agreement upon which the termination is based and (ii) state what the Agency must do to cure such

State of New Mexico
General Services Department
Purchasing Division
Statewide Price Agreement #: 30-00000-23-00091

Page-5

material breaches. Contractor's notice of termination shall only be effective (i) if the Agency does not cure all material breaches within the thirty (30) day notice period or (ii) in the case of material breaches that cannot be cured within thirty (30) days, the Agency does not, within the thirty (30) day notice period, notify the Contractor of its intent to cure and begin with due diligence to cure the material breach. Termination of this Contract, however, shall not affect any outstanding orders. This provision is not exclusive and shall not waive other rights and remedies afforded either party in the event of breach of contract or default. In such instances the contract may be cancelled effective immediately.

Article VI – Amendment

This Price Agreement may be amended by mutual agreement of the New Mexico State Purchasing Agent or his/her designee and the Contractor upon written notice by either party to the other. An amendment to this Price Agreement shall not affect any outstanding orders issued prior to the effective date of the amendment as mutually agreed upon, and as published by the New Mexico State Purchasing Agent or his/her designee. Amendments affecting price adjustments and/or the extension of a price agreement expiration date are not allowed unless specifically provided in the bid and price agreement specifications.

Article VII – Indemnity Clause

Contractor shall indemnify and hold harmless the State, its officers and employees, against liability, claims, damages, losses or expenses arising out of bodily injury to persons or damage to properties caused by, or resulting from Contractor's, and/or its employees, own negligent act or omission while Contractor, and/or its employees, perform or fails to perform its obligations and duties under the Terms and Conditions of this agreement. This save harmless and indemnification clause is subject to the immunities, provisions, and limitations of the Tort Claims Act (Section 41-4-1, et seq., N.M.S.A. 1978 comp. and Section 57-7-1 N.M.S.A. 1878 comp. and any amendments thereto.

It is specifically agreed between the parties executing this agreement that it is not intended by any of the provisions of any part of the agreement to create in the public or any member thereof a third party beneficiary or to authorize anyone not a party to the agreement to maintain a suit(s) for wrongful death(s), bodily and/ or personal injury(s) to person(s), damage(s) to property(ies) and/or any other claim(s) whatsoever pursuant to the provisions of this agreement.

Vendor shall provide all insurance necessary to employees on the work site, including but not limited to Worker's Compensation.

Article VIII – Issuance of Orders

Only written signed orders are valid under this Price Agreement.

Article IX – Packing (if applicable)

Packing shall be in conformance with standard commercial practices.

Article X – Price Schedule

Prices as listed in the price schedule hereto attached are firm.

State of New Mexico
General Services Department
Purchasing Division
Statewide Price Agreement #: 30-00000-23-00091

Page-6

Awarded Vendors:

(AA) 0000051213

Accent Landscape Contractor's
PO BOX 30983

Albuquerque, NM 87190
(505) 881-4880
admin1@accentnm.com

Payment

Term: Net 30
FOB: Destination
5919 Edith Blvd NE Albuquerque, NM
87107
Delivery:

(AB) 0000174693

Charly Landscaping LLC
2637 Redwood
Street
Santa Fe, NM
87505
(505) 780-9593
charlylandscapingllc@gmail.com

Payment

Term: Net 30
FOB: Destination
Delivery: Destination

(AC) 0000174716

Saucedos Janitorial Service
3321 Box Canyon
Gallup NM 87301
(505) 879-3967
levisaucedo@gmail.com

Payment

Term: 30
FOB: Destination
Delivery: upon contract

(AD) 0000106658

Steamer Inc
dba Proscap Landscape Management
1850 Old Pecos Trail Ste J
Santa Fe, NM
87505
(505) 455-9348
office@proscapenm.com

Payment

Term: net 30
FOB: Destination
Delivery: as requested

(AE) 0000050257

Westwind Landscape Construction,
Inc.
PO Box 35969
Albuquerque, NM 87176
(505) 842-7690
patrick@westwindlandscape.com

Payment

Term: Net 30
FOB: Destination
Delivery: Destination

State of New Mexico
General Services Department
Purchasing Division
Statewide Price Agreement #: 30-00000-23-00091

Page-7

Specifications:

The State of New Mexico, General Services Department (GSD), wishes to establish a price agreement for On-Call Grounds Landscaping and Property Maintenance Services and work related to these areas. This Price Agreement may be utilized by all New Mexico State Agencies, commissions, political subdivisions and local public bodies applicable by law.

Vendor shall furnish all labor, tools, specialized equipment, material, supplies, supervision and transportation to perform landscape maintenance and grounds services as specifically outlined in this bid.

Term:

The term of this agreement shall be for one (1) year from date of award with the option to extend for a period (s) of seven (7) additional years, on a year-by-year basis, by mutual agreement of all parties and approval of the New Mexico state purchasing director at the same price, terms and conditions. This Price Agreement may not exceed eight (8) years in total.

Payment Provisions:

Contractor shall submit invoices or pay requests at regular intervals but not less than once a month. Pay requests will be based on Lump Sum Fixed Price and percent of project completion. If there are anticipated to be more than several pay applications for the project, then a schedule of values must be submitted and approved after the Notice to Proceed is issued. Within fifteen (15) days after the date the Department receives written notice from the Contractor that payment is requested for services, construction or items of tangible personal property delivered on site and received, the Department shall issue a written certification of complete or partial acceptance or rejection of the services, construction, or items of tangible personal property. If the Department finds that the services, construction, or items of tangible personal property are not acceptable, it shall, within thirty (30) days after the date of receipt of written notice from the Contractor that payment is requested, provide to the Contractor, a letter of exception explaining the defect or objection to the services, construction, or delivered tangible personal property along with the details of how the Contractor may proceed to provide remedial action.

Upon certification by the Department that the services, construction, or delivered tangible personal property have been received and accepted, payment shall be tendered to the Contractor within thirty (30) days after the date of certification. If payment is made by mail, the payment shall be deemed tendered on the date it is postmarked. After the thirtieth (30th) day from the date that written certification of acceptance is issued, late payment charges shall be paid on the unpaid balance due on the contract to the Contractor at the rate of one and one half percent (1-1/2%) per month. For purchases funded by state or federal grants to local public bodies, if the local public body has not received the funds from the federal or state funding agency, but has already certified that the services or items of tangible personal property have been received and accepted, payments shall be tendered to the Contractor within five (5) working days of receipt of funds from that funding agency.

Final payment shall be made within thirty (30) days after the work has been approved and accepted by the Department's Secretary or his duly authorized representative.

The Contractor agrees to comply with state laws and rules pertaining to Worker's Compensation Insurance coverage for its employees. If Contractor fails to comply with the Worker's Compensation Act and applicable rules when required to do so, the Price Agreement may be cancelled effective immediately.

Tax Note:

Price shall not include state gross receipts tax or local option tax. Such tax or taxes shall be added at time of invoicing at current rate, and shown as a separate item to be paid by user at the current tax rate at the project's location.

Note To Bidders: Do not include New Mexico gross receipts tax in your pricing on this invitation to bid.

State of New Mexico
General Services Department
Purchasing Division
Statewide Price Agreement #: 30-00000-23-00091

Page-8

Bidding Information:

The conditions and specifications set out in the invitation to bid are inseparable and indivisible. Any Vendor, by submitting a bid, agrees to be bound by all such conditions and/or specifications. All conditions and specifications in the invitation to bid, and all other documents required to be submitted, shall be submitted by the Vendor in their bid package. Failure to do so or any attempt to vary or change the conditions or specifications of the invitation to bid shall, at the discretion of the State of New Mexico, constitute grounds for rejection of the entire bid.

The prices quoted herein represent the total compensation to be paid by the State of New Mexico for goods and/or services provided. It is understood that the vendor providing said goods and/or services to the State of New Mexico is responsible for payment of all costs of labor, equipment, tools, materials, federal taxes, permits, licenses, fees, and any other items necessary to complete the work provided. The prices provided or quoted in this price agreement include an amount sufficient to cover such costs.

Minimum Requirements:**General Scope of Work for Landscaping and Grounds Maintenance, shall include but is not limited to:****Vendor shall furnish all labor, tools, specialized equipment, material, supplies, supervision and transportation to perform landscape maintenance and grounds services as specifically outlined in this bid.**

- 1) Mowing grass: height will be dictated by the Procuring Agency. Generally, the grass will be kept cut at a nominal groomed height suited for the location, slope of terrain, and grass condition
- 2) Edging of grass shall be accomplished by mechanical means to all plant beds, tree rings, buildings, sidewalks, driveways, fences, and other surfaced areas bordered by grass.
- 3) Weed control will be maintained within the specified areas including sidewalks, lawns, shrubs and ground cover beds, planters, and areas covered with ornamental rocks.
- 4) Pruning of shrubs and ground cover plants shall be done on an as needed basis to prevent encroachment of passageways, sidewalks, streets, parking areas, and signs. Pruning shall be done to encourage an informal shape, fullness, and bloom, and to keep plants in healthy growing condition.
- 5) Tree and palm/leave trimming shall be done to maintain trees in a healthy, growing condition and is limited to branches and/or brown fronds and seed heads. All sucker growth (chinese elms) will be removed by the root, as requested by the Procuring Agency.
- 6) Plants and trees will be trimmed so that they do not touch the buildings and interfere with walkways and parking areas.
- 7) Removal of leaves and other organic debris from parking lots, courtyards, sidewalks, and adjacent parking areas, and areas that are covered with ornamental rock, as requested by the Procuring Agency. Removal of landscaping debris and piles, as collected, shall be removed by the Contractor.
- 8) Fertilizing all grass or turf areas at a mixture at/or by industry standards and should be applied at/or by the nominal rate as applicable by manufacture standard or industry standards for each application.
- 9) Fertilizing trees at a mix rate at/or by industry standards and should be applied at/or by the nominal rate as applicable by manufacture standard or industry standards for each application.

State of New Mexico
General Services Department
Purchasing Division
Statewide Price Agreement #: 30-00000-23-00091

Page-9

- 10) Pesticides will not be used unless plant damage is evident. Only pesticides that are considered environmentally safe will be used on the property and at the request of the Procuring Agency.
- 11) Mulching should be maintained at a minimum depth of 3 inches or at the request of the Procuring Agency.
- 12) Power washing in identified areas to various hardscape amenities or areas as directed at the request of the Procuring Agency.
- 13) Graffiti removal by power washing in identified areas to various hardscape amenities or areas as directed at the request of the Procuring Agency.
- 14) Irrigation installation in various areas as directed at the request of the Procuring Agency.
- 15) Emergency Irrigation repairs:
 - a) Trouble shooting;
 - b) Include locating source of leaks and making necessary repairs in order to eliminate leak;
 - c) Repairs shall be made with the same brand, make, and model of component where the use of a different part will adversely affect the system efficiency, unless parts are obsolete; and
 - d) Check and maintain irrigation systems for efficient water application reducing overspray and eliminating all runoff from leaving the planted areas.
- 1) Tree planting: replacement of trees, shrubs or bushes. NOTE: Tree planting shall be of the installation of various sizes of plant material, to include broadleaved or coniferous trees or other native species or as requested by the Procuring Agency. Contractor shall be responsible for notifying Underground Utility Service Alert a minimum of forty-eight (48) hours in advance to allow for proper locating of underground utilities. Contractor shall be responsible for delineation of sites for notification unless otherwise directed by Procuring Agency. All trees planted shall be planted in accordance the American National Standards Institute ANSI A300 Part 6: Tree, Shrub and Other Woody Plant Maintenance.
- 2) Grass planting: this shall include, sods, native grass, seeding, soil additives and top soils.
- 3) Gravel and decorative rock: this shall include, pea gravel, crushed decorative gravel, crushed stone, and landscape fabrics (water permeable).
- 4) Snow Removal (seasonal): Provide all labor, equipment and supervision necessary to provide winter month snow plowing & snow/ice removal and sanding services in the parking lots and/or adjacent roadways, to all sidewalks, driveways, and other surfaced areas bordering buildings and/or as directed at the request of the Procuring Agency.
- 5) Trash and Debris removal: Areas identified for debris removal is bounded by the Procuring Agency. This may include but is not limited to, parking lots, adjacent property limits which includes all public property or Right-of-Ways (ROW) areas and may include private segments within the jurisdictional boundaries of the state agencies, local public bodies and/or municipalities procuring the services. Debris removal on non-City or State or County roadways, waterways or other areas, as directed in writing by the Procuring Agency. Debris or trash removal may be as small as or in excess of one (1) bushel basket shall be removed within the designated area so as to leave a clean and appealing sight. No debris shall be left on the road surface. No single piece of debris larger than six (6) inches in any dimension shall be left onsite.
- 6) Artificial or Synthetic Turf grass: Must be athletic caliber synthetic turf systems with height and texture as requested by the Procuring Agency. To be used in any and all adjacent property limits which includes all public

State of New Mexico
General Services Department
Purchasing Division
Statewide Price Agreement #: 30-00000-23-00091

Page-10

property or Right-of-Ways (ROW) areas and may include private segments within the jurisdictional boundaries of the state agencies, local public bodies and/or municipalities procuring the services.

- a) The surface to receive the synthetic turf shall be inspected by the Installer, and prior to the beginning of installation, the Installer must accept in writing the sub-base surface planarity. The surface must be perfectly clean as installation commences and shall be maintained in that condition throughout the process.
- b) Install in accordance with Procuring Agency instructions. Any variance from these requirements must be accepted in writing, by Procuring Agency and/or accepted by the Architect/Owner (if applicable), verifying that the changes do not in any way affect the warranty. Infill materials shall be approved by Procuring Agency and installed in accordance with Procuring Agency standard procedures.
- c) The carpet rolls are to be installed directly over the properly prepared aggregate or acceptable asphaltic-concrete or concrete base. Extreme care should be taken to avoid disturbing the aggregate base, both in regard to compaction and planarity. It is suggested that static roller be used to repair and properly compact any disturbed areas of the aggregate base.
- d) The full width rolls shall be laid out across the area. Turf shall be of sufficient length to permit full cross-field installation. No cross seams will be allowed. Utilize standard state of the art stitching or sewing procedures. Gluing of rolls shall not be acceptable. Minimum gluing will only be permitted to repair problem areas, corner completions, and to cut or inlaid lines as required by the specifications. All seams shall be sewn Procuring Agency high grade thread or adhered Procuring Agency seaming tape and high grade adhesive (per the manufacturer's standard procedures). Seams shall be flat, tight, and permanent with no separation or fraying.
- e) The infill material shall be installed to a depth determined by Procuring Agency
- f) The Infill materials shall be installed to fill the voids between the fibers and allow the fibers to remain vertical and non-directional. The Infill installation consists of a base layer of sand followed by a homogenous mixture of the sand and the cryogenically processed rubber. A final application of specifically sized cryogenically processed rubber completes the system. The Infill shall be installed to the depth of 75%; Infill density shall be installed per the manufacturer's standard procedures.
- g) Synthetic turf shall be attached to the perimeter edge detail in accordance with the Procuring Agency standard procedures. The perimeter edge detail must be designed to provide a permanent edge attachment for the turf fabric so as to prevent the fabric from creating a tripping hazard at the edge of the field.
- h) Warranty - Installer shall provide an (2) year warranty on workmanship.

Purchase Orders:

Under the terms and conditions of this Price Agreement all State of New Mexico agencies may issue purchase orders for items and/or services described herein. The terms and conditions of this Price Agreement shall form a part of each order issued hereunder.

Public Works Minimum Wage Act:

This is a Public Works contract subject to the provisions of the Public Works Minimum Wage Act, Section 13-4-11 through 13-4-17, et seq. NMSA 1978 as amended. Minimum Wage Rates as determined and published by the New Mexico Department of Workforce Solutions, Public Works Bureau, Santa Fe, New Mexico, shall be in effect and utilized by the vendor during the life of this price agreement.

You are hereby advised that wherever differences exist between the minimum wage rates shown under wage decisions of the New Mexico Department of Workforce Solutions, Public Works Bureau, Santa Fe, New Mexico, and those

State of New Mexico
General Services Department
Purchasing Division
Statewide Price Agreement #: 30-00000-23-00091

Page-11

shown under U.S. Department of Labor Wage Decision and any modification thereto noted in the contract assembly, the higher wage rates shall govern.

If a Contractor or subcontractor is willfully paying his laborers, mechanics, or operators less than the rates required by the agreement for the work the laborers, mechanics, and operators are performing, the contractor or subcontractor may lose his right to proceed with the work.

Contract Order:

At time of every task order issued for projects over sixty thousand dollars (\$60,000.00), a Wage Rate Decision number must be requested by end user of the user Agency. The Wage Rate Decision number can be obtained by contacting Work Force Solutions at <https://www.dws.state.nm.us/public-works>. Wage Rates must be attached to each contract order issued.

Performance, Payment and Material Bonding:

Upon the issuance of a purchase order, the awarded Vendor(s) must provide a 100% performance bond and a 100% payment and material bond executed by a surety company authorized to do business in the State of New Mexico will be required of the successful bidder(s) prior to each project over \$25,000.00. Said bonds must be provided to the requesting agency and are to be filed with the agency's purchasing office. Failure to comply shall result in order being issued to another vendor and difference being charged back to the awarded contractor(s). Bond cost shall be billed as an actual cost with no markup. A copy of the bond is required to be sent to the Agency.

Firm Lump Sum Fixed Price:

The total project contract amount represents the total compensation to be paid by the state for goods and/or services provided and referred to hereafter as the firm lump sum fixed price. It is understood that the party providing said goods and/or services in such lump sum fashion to the state is responsible for payment of all its costs necessary to complete the work including but not limited to labor, equipment, tools, materials, subcontractors, professional services fee for drawings and specifications if not provided, taxes, licenses, fee, permits, bonds if required, profit and overhead and insurance. The prices provided herein represent the total compensation to be paid by the State for goods and/or services provided.

General:

All work shall be performed in accordance with the New Mexico building codes. When applicable, the awarded contractor shall be responsible for all permits associated with this work as required by the State of New Mexico, Construction Industries Division. The Construction Industries Division will issue permits for work performed at state owned buildings. Permit costs shall be billed as an actual cost with no markup.

The contractor will be contacted on an as needed basis to perform work associated with this contract. The Procuring Agency may solicit quotes from more than one vendor listed in this price agreement. The contractor may lower his rates on any of the bid items in order to submit a more competitive quote. The Procuring Agency may issue a purchase order to the contractor with the lowest quote that meets all of the requirements of the scope of work. The Procuring Agency reserves the right to accept offers from contractors that desire to submit quotes which better meet the hours and identified costs in order to obtain a fair and reasonable price based on the level of effort and mix of labor proposed to perform. Upon agreement of the cost by the contractor and the Procuring Agency, a firm lump sum fixed price purchase order will be executed.

The contractor and the subcontractors' employees agree to cooperate with and to abide by the rules and requirements of the requesting state agency to not interfere with the daily operations of the agency or to jeopardize the health, safety or welfare of the Procuring Agency's employees or general public conducting business with the state.

State of New Mexico
General Services Department
Purchasing Division
Statewide Price Agreement #: 30-00000-23-00091

Page-12

Contractor Identification:

Persons or employees assigned to work in or on all properties shall be identifiable as an employee of said contractor. A typical method of identification would be a uniform containing the name of the person and/or company logo and name or any combination of identity. Additionally, all service vehicles shall be clearly marked as to contractors name or logo or any combination so as to be visible on the fleet.

The Bidder is responsible for direct supervision of the landscape maintenance personnel. The supervisor or designee with the authority to act, shall always be available, to respond to emergency calls and at all reasonable times to report to and confer with the Procuring Agency.

Debarred or Suspended Contractors:

A business (Contractor, Subcontractor, or Supplier) that has either been debarred or suspended pursuant to the requirements of Sections 13-1-177 through 13-1-180, and 13-4-11 through 13-4-17, NMSA 1978, shall not be permitted to do business with the State and shall not be considered for award of contract during the period for which it is debarred or suspended.

Bribes, Gratuities and Kickbacks:

It is illegal in the State of New Mexico for any public employee to solicit or accept anything of value in connection with award of contract for this Bid and for any person to offer or pay anything of value to any such public employee (30-24-1 and 30-24-2, NMSA 1978).

Pursuant to Section 13-1-191, NMSA 1978, reference is hereby made to the Criminal Laws of New Mexico (including Sections 30-24-1 through 30-24-3, NMSA 1978, and 30-41-1 through 30-41-3, NMSA 1978), which prohibit bribes, kickbacks, and gratuities, violations of which constitutes a felony. Further, the Procurement Code (Sections 13-1-28 through 13-1-199, NMSA 1978) imposes civil and criminal penalties for its violation.

Assignment of Antitrust Claims:

The Contractor agrees that any and all claims that the Contractor may have or that may inure to the Contractor for overcharges resulting from antitrust violations as to goods, services, and materials purchased in connection with this Bid are hereby assigned to the State of New Mexico, but only to the extent that such overcharges are passed on to the State. The Contractor further agrees to require each of its Suppliers, Subcontractors, and Sub subcontractors to assign any and all such claims for overcharges to the State by executing an assignment on the form provided by the Owner for such purpose. The executed form (see Section 00600-7) shall be submitted prior to the commencement of the Work or the supplying of any materials by the Supplier, Subcontractor, or Sub subcontractor. The submission of this executed form may be waived by the Owner upon a showing of a good-faith effort by the Contractor to obtain agreement in writing from his Supplier, Subcontractor, or Sub subcontractor. Waiver by the Owner may not unreasonably be denied.

It is agreed that the Contractor retains all rights to any such antitrust claims to the extent of any overcharges not passed on to the State, including the right to any treble damages attributable thereto.

Subcontractors:

Subcontractors are allowed to work on this contract only with written prior approval by the agency contracting for the work. Subcontractors' activities must be defined and the cost of their work broken out on a separate line(s) on the quote. The subcontractor's quote must follow the price agreement item breakdown and have materials itemized. If a subcontractor's quote is included in the accepted primary contractor's quote then subcontractor approval is implied. If a contractor desires to change the subcontractor after contract award, written approval must be obtained from user agency.

The Primary contractor will be wholly responsible for the entire performance of the subcontractor and must adequately supervise the work of the subcontractor in order to ensure that the quality of their work meets the State's standards. Subcontractors are subject to the same applicable licensing and insurance coverage as the primary contractor. Subcontractors who have been suspended or debarred from doing state or federal work may not be used by the Primary Contractor.

State of New Mexico
General Services Department
Purchasing Division
Statewide Price Agreement #: 30-00000-23-00091

Page-13

The awarded vendor may NOT add a markup for subcontracted work.

Scope of Work for upgrades to new or existing electrical, plumbing or landscape irrigation systems, diagnostic services and performance.

Contractor(s) shall be capable of providing all new or upgrades or repairs to existing electrical, plumbing or landscape irrigation systems, diagnostic services, perform trouble shooting services and to prepare proposals for all costs and services needed to perform the work required, in compliance with the national and state electrical and plumbing codes. The Procuring Agency shall provide, a detailed scope of work and/or drawings, generally defining the electrical or plumbing / landscape irrigation work required for the project.

All work shall be performed in a neat and workmanlike manner, while maintaining the work area(s) in a clean condition. All work shall be installed in strict compliance with industry standards, by workers trained and certified to perform the work. All materials shall be new and of the highest quality available for the type of work being performed.

The Contractor shall provide all protective coverings necessary to protect existing finishes and improvements which are in the area where the new work will occur.

The Contractor shall restore any damage to existing finishes. Restoration work shall be inconspicuous with existing finishes.

The Contractor shall provide all clean-up for its operations. All hazardous and non-hazardous construction debris shall be removed from the work areas and disposed of at an approved waste disposal site. The owner's trash container for the building shall not be used for disposal of construction debris.

Labor:

Personnel working on the project and providing these services shall be experienced in all areas related to this work and required by this contract. Supervisor and/or Journeymen level personnel shall have the ability and necessary skills to diagnosis problems and to make the appropriate decisions needed to provide these services.

***** End of Scope of Work *****

Materials, Subcontracts and Other Associated Costs:

Materials, subcontracts and other associated costs necessary to perform the work stipulated in the scopes of work shall be itemized with pricing. After acceptance of the costs identified in this section by the Agency, those costs shall be treated as provided in the section on Firm Lump Sum Fixed Price. If there is to be a discount on the retail materials, the quote must show the discount.

All material specified in the prices provided, regardless of whether incorporated in the work shall be deemed included as paid for by the Owner or Procuring Agency. As such, any unused materials shall be turned over to the Owner or Procuring Agency for whom the work was provided. The State of New Mexico requires that all materials shall be new and of the highest quality and at the best attainable price available for the type of work being performed.

Awarded vendors may NOT add a markup for materials, subcontractors, equipment rental or any associated costs. Profit and overhead markups are not allowed.

Equipment Rental:

If special equipment is required to perform the work required, the Contractor may quote the cost of said equipment. The Procuring Agency will have final determination and decision, if specialized equipment is truly required for the project

State of New Mexico
General Services Department
Purchasing Division
Statewide Price Agreement #: 30-00000-23-00091

Page-14

Quote Request:

When a service is needed, the Procuring Agency shall provide, at a minimum, a detailed scope of work and/or drawings (if required) defining work required.

The Contractor shall make an effort to visit the site and compare the owner's scope of work and/or drawings to the existing conditions and provide all services called for in addition to the requirements set forth in this price agreement.

The Contractor will be required to provide a written quote at no cost to the State, to include the work to be performed as well as the number of days required for the completion of the project and submit it to the Procuring Agency or local public body.

Change Orders:

Change Orders are lump sum amounts which are added to the Purchase Order as a line item or put into a new Purchase Order. They are to be used for unforeseen conditions or Agency identified but non estimated work. When they are quantified and identified, the resultant cost must be submitted to the Agency with subcontractor quotes. No extra work can be started until the Change Order is approved in writing and the Purchase Order is approved.

Written justification shall accompany the request. The justification shall include the reason, the scope, the history of the issue, the place of the work and any other relevant details.

Work Commencement:

Prior to commencement of any work performed the Procuring Agency will issue a notice to proceed for the work upon receipt of a purchase order, based on the prices set forth by vendor's quote. The Contractor is required to submit a work schedule which will indicate the approximate completion date of the project. It should be updated with any changes as the work proceeds. The contractor shall begin the work based on the priority identified by the Procuring Agency. Any delay beyond the stated completion date shall be upon agreement by the owner and the contractor. If submittals or shop drawings are required, then they must be approved before the relevant work is started.

The Contractor shall supervise and direct the work. He shall be solely responsible for all construction means, methods, techniques, sequences and procedures and for coordinating all portions of the work under the project. The contractor shall be responsible to the Procuring Agency for the acts and omissions of his employees and, if prior approved, Subcontractors and their agents and employees and other persons performing any of the work under a contract with the Contractor.

Where work is to be conducted in a state correctional or secured facility, security clearances and background checks that may be required by the facility for the contractor and its employees must be obtained prior to commencement of any work at that facility. The Procuring Agency reserves the right to deny any employee of the contractor, access to the facility should the employee be in violation of any criteria required for the security clearance.

The Procuring Agency or local public body reserves the right to provide an escort and/or full time supervision of the contractor and its employees during any or all phases of a project, should the Procuring Agency feel it is in its best interest to provide these extraordinary security services.

The Procuring Agency or local public body reserves the right to escort any or all employees of the contractor off its property, for any inappropriate conduct or actions that jeopardize the safety, security or well-being of the facility. Inappropriate behavior by the contractor, its employees or subcontractors shall immediately cancel this contract. Any employee of the contractor found in violation of any law, while on the user agency's property, will be prosecuted.

The Procuring Agency or local public body may order the Contractor to stop the work or a portion of it if the contractor fails to correct defective work or persistently fails to carry out the work. The Procuring Agency would do so in writing with justifications with the knowledge that if the 'stop work' was not sufficiently justified, the contractor may be owed for demobilizing and remobilizing.

State of New Mexico
General Services Department
Purchasing Division
Statewide Price Agreement #: 30-00000-23-00091

Page-15

Review of Project Documents:

The Contractor shall carefully study and compare the project documents and shall report at once to the Procuring Agency any error, inconsistency or omission he may discover. If this occurs during the work, the Contractor shall not continue the related work until the issue is resolved.

Safety:

The Contractor is responsible for initiating, maintaining, and supervising all safety precautions and programs in connection with the work. This includes precautions to prevent damage, injury or loss to: 1) all employees on the work and all other persons who may be affected thereby, 2) all the work and all materials and equipment to be incorporated therein, whether in storage on or off site, under the care, custody or control of the Contractor or any of his Subcontractors or sub-Subcontractors, 3) other property at the site or adjacent thereto, including trees, shrubs, lawns, walks, pavements, roadways, structures and utilities not designated for removal, relocation or replacement in the course of construction.

The Contractor shall erect and maintain, as required by existing conditions and progress of work all reasonable safeguards for safety and protection, including posting danger signs and other warnings against hazards, promulgating safety regulations and notifying agencies and users of adjacent utilities. All OSHA regulations shall be followed as well as any other Codes which pertain to safety procedures.

Warranties:

The Contractor warrants to the Procuring Agency that all work and all materials and equipment furnished under this price agreement will be of good quality, free from defects and faults and in conformance with the Project documents. All work not conforming to these requirements, including substitutions not properly approved and authorized, may be considered defective. If required by the user agency, the contractor shall furnish satisfactory evidence as to the kind and quality of the materials and equipment. Unless otherwise specified, the contractor's workmanship, materials and equipment will be warranted for a period of one year beginning at the agreed upon date of substantial completion.

Escalation / Reduction Clause:

Contractor shall keep pricing fixed for each year of this Agreement. Thereafter, SPD and the Contractor may adjust pricing no more than once biennially through an amendment to the Agreement at the time of Agreement renewal. Contractor shall submit all pricing increase requests to SPD directly or through the agency contact in writing and provide substantiating evidence that each request is based on demonstrable market changes impacting the cost of products. The request must show all proposed increases by line item and include supporting documentation acceptable to SPD (such as a letter from a manufacturer indicating price increases, etc.) SPD's decision on what is acceptable in this context is final and shall be accepted by all parties to the Agreement. Requested price increases that exceed 10% will not be accepted. No price increase may result in a higher profit margin for the Contractor than at the beginning of the initial term of this Agreement. Pricing changes will apply to Agreements and amendments to Agreements entered on and after the effective date of the price change. Price decreases as well as increases shall apply in the same manner. If vendor's prices are reduced for any reason, users shall receive the benefit of such reductions, immediately. Price increases will not be retroactive to orders already in house or backorders. Orders will be filled at the price in effect on the date of receipt of the order by the vendor. To facilitate prompt consideration, all requests for price increase must include all information listed below:

1. Agreement Item Number
2. Current Item Price
3. Proposed New Price
4. Percentage of Increase
5. Mill/Supplier Notification of price increase indicating percentage of increase including reason for increase.

State of New Mexico
General Services Department
Purchasing Division
Statewide Price Agreement #: 30-00000-23-00091

Insurance:

The contractor shall provide all insurance necessary for its employees on the project, including, but not limited to, workman's compensation insurance. The contractor agrees to comply with state laws and rules pertaining to workers' compensation insurance coverage for its employees. If the contractor fails to comply with the workers' compensation act and applicable rules, when required to do so, this contract will be cancelled immediately.

Contractor shall indemnify and hold harmless the state, its officers and employees against liability claims, damages, losses or expenses arising out of bodily injury to persons or damage to property caused by or resulting from the contractor's, and/or its employees, own negligent act(s) or omissions while the contractor, and/or its employees, perform(s) or fails to perform its obligations and duties under the

Terms and Conditions of this agreement. This "save harmless and indemnification" clause is subject to the immunities, provisions and limitations of the tort claims act (41-4-1, et seq., N.M.S.A. 1978 comp), section 57-7-1 N.M.S.A. 1978 comp. and any amendments thereto.

It is specifically agreed between the parties executing this agreement that it is not intended by any of the provisions of the agreement to create the public or any member thereof a third party beneficiary or to authorize anyone not a party to the agreement to maintain a suit(s) for wrongful death(s), bodily and/or personal injury(ies) to person(s), damages to property(ies) and/or any other claim(s) whatsoever, pursuant to the provisions of this agreement.

The contractor shall provide public liability insurance for the minimum amount of \$300,000 for damage to or destruction of property arising out of each occurrence; the amount of \$300,000 to any person for any number of claims arising out of each occurrence for all damages other than property damage as permitted under the New Mexico tort claims act; and the amount of \$1,00,000 for all claims arising out of each occurrence.

Method of Award:

The State Purchasing Agent reserves the right to award this Invitation to Bid per zone in total; by groups of items; on the basis of individual items; any combination of these which could result in a multiple award; or as otherwise specified in bid specifications; whichever, in his/her judgment, best serves the interest of the State of New Mexico.

Multiple Awards:

Determination for award shall be based upon the lowest total cost of all items listed and the bidder's abilities to meet the "minimum and submittal requirements" of the Invitation to Bid. This may be a multiple award contract.

Quantities:

The approximate quantities for each item are estimated and are for bidding purposes only. Actual requirements will be as determined by the using agency at the time of P.O. Quantities may be increased or decreased as necessary to meet actual requirements. The State does not guarantee any amount of work.

CONTRACTOR REQUIRED INFORMATION:

No person shall act as a contractor without a license issued by the Construction Industries Division, classified to cover the type of work to be performed. No bid on a contract shall be submitted unless the contractor has the appropriate valid contractor's license issued by the Construction Industries Division to bid and to perform the type of work to be undertaken, as set forth in § 60-13-12, NMSA 1978.

New Mexico Public Works Registration No. (required at time of bidding): _____

Contractor's New Mexico License No. (required at time of bidding): _____.

Contractor Classification No.: _____.

State of New Mexico
 General Services Department
 Purchasing Division
 Statewide Price Agreement #: 30-00000-23-00091

Page-17

State Tax ID No.: _____

Federal Taxpayer ID No.: _____

Item Description Key:

Item	Approx. Qty.	UOM	Article and Description
1	1	Hourly	On Call General Landscaping and/or Landscape Maintenance
2	1	Hourly	Landscape Irrigation Maintenance and Repair
3	1	SqFt.	Landscape Construction - Landscape specific materials, mulch, ornamental gravel, decorative rocks, grass, artificial turf, water features, exterior lighting, irrigation; installation and/or remodels
4	1	Hourly	Superintendent or Supervisor, regular hours worked
5	1	Hourly	Superintendent or Supervisor, after hours worked
6	1	Hourly	Journeyman or Experienced Worker, regular hours worked
7	1	Hourly	Journeyman or Experienced Worker, after hours worked
8	1	Hourly	Laborer, regular hours worked
9	1	Hourly	Laborer, after hours worked
10	1	Hourly	Mowing, edging, shrub and groundcover pruning, and removal of trash/litter.
11	1	Hourly	Power Washing hardscapes
12	1	Hourly	Tree and shrub planting, decorative plants and grasses
13	1	Hourly	Tree and Stump Removal
14	1	Hourly	Diagnosis, project estimates, troubleshooting, other
15		Percent	Discount off all parts and materials. Invoice will include copies of all purchases for parts and materials, including vendor and date purchased. Enter zero if no discount is offered.

***** 15 Items Total *****

State of New Mexico
 General Services Department
 Purchasing Division
 Statewide Price Agreement #: 30-00000-23-00091

Page-18

	(AA) Accent Landscape Contractor's	(AB) Charly Landscaping LLC	(AC) Saucedos Janitorial Service	(AD) Steamer Inc. dba Proscape Landscape Management	(AE) Westwind Landscape Construction, Inc.
Item	Unit Price	Unit Price	Unit Price	Unit Price	Unit Price
1	\$65.00	\$85.00	\$75.00	\$50.00	\$75.00
2	\$75.00	\$65.00	\$75.00	\$75.00	\$75.00
3	\$10.00	\$62.00	\$25/SqFt.	\$17.00	\$14.00
4	\$85.00	\$65.00	\$150.00	\$65.00	\$98.00
5	\$130.00	\$120.00	\$225.00	\$75.00	\$147.00
6	\$75.00	\$55.00	\$150.00	\$70.00	\$98.00
7	\$115.00	\$110.00	\$225.00	\$75.00	\$147.00
8	\$65.00	\$35.00	\$75.00	\$45.00	\$75.00
9	\$98.50	\$85.00	\$112.50	\$65.00	\$112.00
10	\$65.00	\$40.00	\$75.00	\$75.00	\$75.00
11	\$65.00	\$40.00	\$250.00	\$130.00	\$75.00
12	\$65.00	\$55.00	\$250.00	\$55.00	\$75.00
13	\$65.00	\$55.00	\$350.00	\$160.00	\$75.00
14	\$100.00	\$65.00	\$75.00	\$75.00	\$110.00
15	0%	10%	0%	3%	0%

*** 15 Items Total ***

Certificate Of Completion

Envelope Id: E412BEFB20464B689C1E68D32C036E61	Status: Completed
Subject: GSD/SPD Procurement#: 30-00000-23-00091 Landscaping Statewide	
Source Envelope:	
Document Pages: 18	Signatures: 1
Certificate Pages: 5	Initials: 2
AutoNav: Enabled	Envelope Originator:
Envelope Stamping: Enabled	Arrianna Romero
Time Zone: (UTC-07:00) Mountain Time (US & Canada)	1100 S Saint Francis Dr
	Santa Fe, NM 87502
	Arrianna.Romero1@gsd.nm.gov
	IP Address: 164.64.63.2

Record Tracking

Status: Original	Holder: Arrianna Romero	Location: DocuSign
7/20/2023 3:22:39 PM	Arrianna.Romero1@gsd.nm.gov	
Security Appliance Status: Connected	Pool: StateLocal	
Storage Appliance Status: Connected	Pool: GSD	Location: DocuSign

Signer Events

Signer Events	Signature	Timestamp
Michael Saavedra		Sent: 7/20/2023 3:27:56 PM
Michael.Saavedra@gsd.nm.gov		Viewed: 7/20/2023 3:43:23 PM
New Mexico General Services		Signed: 7/20/2023 3:43:31 PM
Security Level: Email, Account Authentication (None), Login with SSO	Signature Adoption: Pre-selected Style	
	Using IP Address: 164.64.62.10	

Electronic Record and Signature Disclosure:
Accepted: 6/4/2020 11:04:51 AM
ID: 9cac1b3e-4279-4c8f-b2b4-c607ea9821d8

Arrianna Romero		Sent: 7/20/2023 3:43:33 PM
Arrianna.Romero1@gsd.nm.gov		Viewed: 7/21/2023 9:02:28 AM
Purchasing Agent Advance		Signed: 7/21/2023 9:02:47 AM
New Mexico General Services, State Purchasing Division	Signature Adoption: Pre-selected Style	
Security Level: Email, Account Authentication (None)	Using IP Address: 164.64.62.10	

Electronic Record and Signature Disclosure:
Not Offered via DocuSign

Dorothy Mendonca		Sent: 7/21/2023 9:02:49 AM
dorothy.mendonca@gsd.nm.gov		Viewed: 7/21/2023 9:04:05 AM
SPD Division Director / State Purchasing Agent		Signed: 7/21/2023 9:04:23 AM
General Services Department	Signature Adoption: Pre-selected Style	
Signing Group: 35000 - State Purchasing Agent	Using IP Address: 174.205.160.21	
Security Level: Email, Account Authentication (None)	Signed using mobile	

Electronic Record and Signature Disclosure:
Accepted: 4/14/2023 7:24:59 AM
ID: 51f6380f-50f7-4227-afb5-572b373dfb7c

In Person Signer Events	Signature	Timestamp
Editor Delivery Events	Status	Timestamp
Agent Delivery Events	Status	Timestamp
Intermediary Delivery Events	Status	Timestamp

Certified Delivery Events	Status	Timestamp
----------------------------------	---------------	------------------

Carbon Copy Events	Status	Timestamp
---------------------------	---------------	------------------

Witness Events	Signature	Timestamp
-----------------------	------------------	------------------

Notary Events	Signature	Timestamp
----------------------	------------------	------------------

Envelope Summary Events	Status	Timestamps
--------------------------------	---------------	-------------------

Envelope Sent	Hashed/Encrypted	7/20/2023 3:27:56 PM
Certified Delivered	Security Checked	7/21/2023 9:04:05 AM
Signing Complete	Security Checked	7/21/2023 9:04:23 AM
Completed	Security Checked	7/21/2023 9:04:23 AM

Payment Events	Status	Timestamps
-----------------------	---------------	-------------------

Electronic Record and Signature Disclosure

ELECTRONIC RECORD AND SIGNATURE DISCLOSURE

A. ELECTRONIC RECORD AND SIGNATURE DISCLOSURE (ERSD)

From time to time, New Mexico General Services Department (GSD), on behalf of the State of New Mexico (SONM), may be required by law to provide you with certain written notices or disclosures. Stated below are the terms and conditions for GSD's providing you such notices and disclosures electronically through the DocuSign system. Please read this information carefully. If you are able to access this information electronically and agree to **this Electronic Record and Signature Disclosure (ERSD)**, please confirm your agreement by selecting the check-box next to "I agree to use electronic records and signatures" before clicking "CONTINUE" within the DocuSign system.

B. Obtaining paper copies

At any time up to twenty (20) calendar days following your use of DocuSign to electronically sign a document, you may request a paper copy of any record provided or made available electronically to you by GSD. You will have the ability to download and print documents SONM sends you through the DocuSign system during and immediately after the signing session and, if you elect to create a DocuSign account, you may access the documents for a twenty (20) calendar day period after such documents are first sent to you. Following the twenty (20) day period, if you want GSD to send you paper copies of any such documents from GSD's office, you will be charged a \$1.00 per-page fee plus postage. You may request delivery of such paper copies from GSD by following the procedure stated in Section H, below.

C. Withdrawing your consent

If you decide to receive notices and disclosures from GSD electronically, you may at any time change your mind and inform GSD you want to receive required notices and disclosures only in paper format. The procedure concerning how you may inform GSD of your decision to receive future notices and disclosures in paper format as well as withdraw your consent to receive notices and disclosures electronically is stated in Section D, immediately below.

D. Consequences of changing your mind

If you elect to receive required notices and disclosures only in paper format, it will slow the speed with which GSD will be able to complete certain steps in specific transactions and deliver paper copies to you. GSD will need: (1) to send the required notices or disclosures to you in paper format; and (2) wait until GSD receives your acknowledgment of your receipt of such paper notices or disclosures. Further, you will no longer be able to use the DocuSign system to receive required notices and consents electronically from SONM or to electronically sign documents generated and sent to you from SONM.

E. All notices and disclosures will be sent to you electronically

Unless you inform GSD otherwise according to these procedures, GSD will electronically provide you through the DocuSign system all required notices, disclosures, authorizations, acknowledgements and other documents that are required to be provided or made available to you during the course of your electronic signature relationship with SONM. To reduce the possibility of inadvertent non-receipt, GSD prefers to provide all required notices and disclosures by the same method and to the same email or physical address that you furnish to GSD. Thus, you may receive the disclosures and notices electronically or in paper form. If you do not agree with this procedure, please inform GSD according to the procedures stated in Section I, below. Please also refer to Section D, immediately above, which states the consequences resulting from your declination of electronic delivery of notices and disclosures.

F. How to contact GSD:

You may inform General Services Department (GSD) of any changes you select regarding State Purchasing Division's (SPD) electronic communications with you, to request paper copies of certain information from SPD, and to withdraw your prior consent to receive notices and disclosures electronically by emailing your request(s) to SPD at: GSD.SPInfo@state.nm.us

G. To advise SPD of your new email address

To inform SPD of a change in the email address to which SPD sends you notices and disclosures electronically, you must send an email to SPD at GSD.SPInfo@state.nm.us and in the body of such request you must include your previous and new email addresses.

H. To request paper copies from SPD

To request delivery of paper copies of electronic notices and disclosures that DocuSign and/or SPD have previously provided to you, you must send an email to SPD at GSD.SPInfo@state.nm.us and in the body of your email request state your email address, full name, mailing address, and telephone number. SPD will charge you a \$1.00 per page copy fee plus postage.

I. To withdraw your consent with SPD

To inform SPD that you no longer wish to receive notices and disclosures in electronic format you may:

(1) Decline to sign a document from within a signing session, and on the subsequent page, select the check-box indicating you wish to withdraw your consent, or you may:

(2) Send SPD an email to GSD.SPInfo@state.nm.us and in the body of your request state your email address, full name, mailing address, and telephone number.

J. Required hardware and software

The minimum system requirements for using the DocuSign system may change over time. The current DocuSign system requirements may be found at:

<https://support.docusign.com/guides/signer-guide-signing-system-requirements>

K. Acknowledging your access and consent to receive and sign documents electronically

To confirm that you are able to electronically access the information contained in this Electronic Record and Signature Disclosure (ERSD), please confirm that you have: (1) read this ERSD, and either: (2) you are able to print on paper or electronically save this ERSD for your future reference and access; or (3) you are able to email this ERSD to an email address where you will be able to print this ERSD on paper and/or save this ERSD for your future reference and access. Further, if you consent to receiving notices and disclosures from DocuSign and/or SPD exclusively in electronic format, then select the check-box next to “I agree to use electronic records and signatures,” before you click “CONTINUE” within the DocuSign system.

By selecting the check-box next to “I agree to use electronic records and signatures,” you confirm that:

- You have read this Electronic Record and Signature Disclosure (ERSD); and
- You can print this ERSD on paper, or you can save and/ or send this ERSD to a location where you can print this ERSD, for your future reference and access; and
- Until or unless you notify SPD as stated in this ERSD, you consent to exclusively receive through electronic means all notices, disclosures, authorizations, acknowledgements, and other documents that are required to be provided or made available to you by SPD during the course of your electronic signature relationship with SPD.

From: [Matt Loehman](#)
To: [KAHAHANE, ELIZABETH L.](#)
Subject: Re: Horizons Dedination – Install a new irrigation system at the Railyard Park
Date: Wednesday, October 16, 2024 1:38:26 PM
Attachments: [image001.png](#)

CAUTION: This email originated from outside of the organization. Do not click links or open attachments unless you recognize the sender and know the content is safe.

Good afternoon Lisa,

Thank you very much for the opportunity, but we will decline this procurement.

Best regards,

Matt

Matt Loehman
Executive Director

Horizons of New Mexico
6121 Indian School Rd. NE, Suite 220
Albuquerque, NM 87110

office phone: (505) 345-1540
email: mloehman@horizonsofnewmexico.org
web: www.horizonsofnewmexico.org

The State Use Act helps people with disabilities become gainfully employed, and it saves you valuable time and resources otherwise used during the procurement process.

On Wed, Oct 16, 2024 at 11:56 AM KAHAHANE, ELIZABETH L.
<elkahahane@santafenm.gov> wrote:

Hello Matt,

The City of Santa Fe is seeking a Horizons Determination for the following Scope of Work:

- Install a new irrigation system at the S.F. Railroad Park.

Please let me know if you have any questions.

Thanks!

Best,

Elizabeth “Lisa” Kahahane

Contracts Administrator | Facilities Division | Public Works Dept.

Email: elkahahane@santafenm.gov

M: (505) 795-2439

O: (505) 955-5934



From: [DUTTON-LEYDA, TRAVIS K.](#)
To: [KAHAHANE, ELIZABETH L.](#); [Purchasing DET](#)
Cc: [BOHLMAN, JOSHUA B.](#)
Subject: RE: Request SOW Determination for Irrigation System
Date: Friday, September 27, 2024 9:33:05 AM
Attachments: [image003.png](#)

Greetings,

The scope of work as written would be General Services. This determination relates only to that question and is no comment on whether the scope of work or procurement method meet all legal standards. I reserve the right to change this determination if the scope of work differs from the scope of work submitted for the original determination. This procurement must be conducted using the processes and procedures set forth by the City of Santa Fe, Central Purchasing, the Procurement Manual, and state statutes.

Please note:

- Save this email as a PDF and upload it into the corresponding Munis records.
- Check with WorkQuest dba Horizons of New Mexico (vendor # 8673) (mloehman@horizonsofnewmexico.org) if this service appears on their approved list.
- If your request includes anything that needs to be reviewed and preapproved by another city Department/Division, please send your SOW to the corresponding email address, and provide their response to this office when you submit your procurement request for processing.
 - IT components - ereview@santafenm.gov
 - Vehicles – dmjaramillo@santafenm.gov
 - Grants - mtbonifer@santafenm.gov; cmthompson@santafenm.gov
 - Facilities, Furniture, Fixture, Equipment - jsburnett@santafenm.gov
 - Emergency Related Purchases - bgwilliams@santafenm.gov
 - Asset over \$5k - lmstorey@santafenm.gov
- Ensure that the appropriate templates and forms are used https://intranet.santafenm.gov/finance_1 and documented [procedures/laws/rules](#) are followed. _
- > \$20k per year, when processing this procurement, please ensure the procurement number issued by Munis and the procurement name are used in the appropriate documents and the subject of emails.
- If you are processing a procurement where the forecasted amount is => \$60k, per NMSA 1978, Section 13-1-102, the procurement method must be ITB (if you choose not to use a cooperative or an existing contract). If you feel you need to process an RFP, you must get an Authorization and Plan approved before you process.
- < \$20k per year, one quote is acceptable.
From \$20k to \$60k per year, if you aren't using a cooperative or existing contract,

you'll need to provide 3 quotes in your req. Must use the Munis Bid Module after 12/21/2023.

- Please keep this as part of the procurement file for future reference.
- Figure out your funding source and **inform Purchasing**. To ensure that the proper documents and language are used, it is important to identify the funding source for the subsequent contract. For instance, if federal funds are involved, the procurement request and subsequent contract must include the necessary federal language. Therefore, it is crucial to determine the funding source beforehand.
- Please review the pages linked below to determine whether any of the existing contracts/price agreements or cooperative agreements are applicable to this request. You might be able to use an existing price agreement to save time and money.
 - <https://www.generalservices.state.nm.us/state-purchasing/statewide-price-agreements/> (if you choose to use a Statewide, you do not need to ask Horizons if they can do the work. State Purchasing must offer the SOW to Horizons prior to placing the award on their website.)
 - <https://naspo.valuepoint.org/categories/>
 - <https://www.omniapartners.com/publicsector/contracts>
 - <https://www.buyboard.com/home.aspx>
 - <https://www.h-gac.com/Home>
 - <https://www.gsa.library.gsa.gov/>
 - <https://www.sourcewell-mn.gov/contract-search>
- Submit or send your request to the appropriate MS Teams channel or email address:
 - RFPs requests to <https://teams.microsoft.com/l/channel/19%3ad63b9c8b586d424fa5eed34177146ac5%40thread.tacv2/RFP%2520Requests?groupId=a367d8c2-992f-4c74-8e7d-0ccb6950c9a1&tenantId=77b69f5a-55ed-4363-8616-4867b0bc707f>
 - ITBs requests to <https://teams.microsoft.com/l/channel/19%3a48e1e4588c0440a09cfd9b907ed42d4%40thread.tacv2/ITB%2520Requests?groupId=a367d8c2-992f-4c74-8e7d-0ccb6950c9a1&tenantId=77b69f5a-55ed-4363-8616-4867b0bc707f>
 - Determination requests to purchasing_det@santafenm.gov
 - And all other requests to purchasing@santafenm.gov

Thank you for submitting this scope of work for my review.

Regards,

Travis Dutton-Leyda
Chief Procurement Officer

City of Santa Fe
200 Lincoln Avenue
Santa Fe, NM 87501
505-629-8351
tkduttonleyda@santafenm.gov

<https://santafenm.gov/finance-2/purchasing-1>

Vendor Registration and Current Procurement Opportunities:

<https://cityofsantafenmvendors.munisselfservice.com/Vendors/VBids/SearchResults.aspx>

Internal Link: https://intranet.santafenm.gov/finance_1



More Procurement, less drama ~ John Blair

From: KAHAHANE, ELIZABETH L. <elkahahane@santafenm.gov>
Sent: Friday, September 27, 2024 9:19 AM
To: Purchasing DET <purchasing_det@santafenm.gov>
Cc: DUTTON-LEYDA, TRAVIS K. <tkduttonleyda@santafenm.gov>; BOHLMAN, JOSHUA B. <jbohlman@santafenm.gov>
Subject: Request SOW Determination for Irrigation System

Good morning,

Facilities Division is requesting a SOW determination for the following:

Installation of a new irrigation system at the Santa Fe Railyard Park

Thank you!

Best,

Elizabeth "Lisa" Kahahane

Contracts Administrator | Facilities Division | Public Works Dept.

Email: elkahahane@santafenm.gov

M: (505) 795-2439

O: (505) 955-5934



CITY OF SANTA FE

FACILITIES











Contract Packet_Railyard Irrigation 12 16 2024 _JB3 TF1 ELK RW2 SB4

Final Audit Report

2024-12-18

Created:	2024-12-16
By:	Elizabeth Kahahane (elkahahane@santafenm.gov)
Status:	Signed
Transaction ID:	CBJCHBCAABAAyUFRQE0QQ32sJGgEDjw3J6IpfkNIOEHI

"Contract Packet_Railyard Irrigation 12 16 2024 _JB3 TF1 ELK RW2 SB4" History

-  Document created by Elizabeth Kahahane (elkahahane@santafenm.gov)
2024-12-16 - 11:23:57 PM GMT- IP address: 63.232.20.2
-  Document emailed to JOSHUA BOHLMAN (jbohlman@santafenm.gov) for signature
2024-12-16 - 11:32:27 PM GMT
-  Email viewed by JOSHUA BOHLMAN (jbohlman@santafenm.gov)
2024-12-17 - 5:17:35 PM GMT- IP address: 104.47.65.254
-  Document e-signed by JOSHUA BOHLMAN (jbohlman@santafenm.gov)
Signature Date: 2024-12-17 - 5:17:44 PM GMT - Time Source: server- IP address: 63.232.20.2
-  Document emailed to Melissa McDonald (mamcdonald@santafenm.gov) for signature
2024-12-17 - 5:17:56 PM GMT
-  Email viewed by Melissa McDonald (mamcdonald@santafenm.gov)
2024-12-17 - 7:08:34 PM GMT- IP address: 63.232.20.2
-  Document e-signed by Melissa McDonald (mamcdonald@santafenm.gov)
Signature Date: 2024-12-17 - 7:09:18 PM GMT - Time Source: server- IP address: 63.232.20.2
-  Document emailed to JOHN BURNETT (jsburnett@santafenm.gov) for signature
2024-12-17 - 7:09:21 PM GMT
-  Email viewed by JOHN BURNETT (jsburnett@santafenm.gov)
2024-12-17 - 7:39:49 PM GMT- IP address: 174.240.21.162
-  Document e-signed by JOHN BURNETT (jsburnett@santafenm.gov)
Signature Date: 2024-12-17 - 7:41:18 PM GMT - Time Source: server- IP address: 73.228.3.65



 Document emailed to rawheeler@santafenm.gov for signature

2024-12-17 - 7:41:20 PM GMT

 Email viewed by rawheeler@santafenm.gov

2024-12-18 - 0:26:14 AM GMT- IP address: 104.47.65.254

 Signer rawheeler@santafenm.gov entered name at signing as Regina Wheeler

2024-12-18 - 0:26:28 AM GMT- IP address: 63.232.20.2

 Document e-signed by Regina Wheeler (rawheeler@santafenm.gov)

Signature Date: 2024-12-18 - 0:26:30 AM GMT - Time Source: server- IP address: 63.232.20.2

 Agreement completed.

2024-12-18 - 0:26:30 AM GMT

Contract Packet_Railyard Irrigation 12 16 2024 _JB3 TF1 ELK RW2 SB4 v3

Final Audit Report

2025-01-30

Created:	2025-01-21
By:	JAMES EDWARDS (jwedwards@santafenm.gov)
Status:	Signed
Transaction ID:	CBJCHBCAABAAC5X3kYJsiP5XLKIHmm9ZtP-qeHrszv6v

"Contract Packet_Railyard Irrigation 12 16 2024 _JB3 TF1 ELK RW2 SB4 v3" History

 Document created by JAMES EDWARDS (jwedwards@santafenm.gov)
2025-01-21 - 9:53:51 PM GMT- IP address: 63.232.20.2

 Document sent to ALEXIS LOTERO (aclotero@santafenm.gov) and ajhopkins@santafenm.gov
ajhopkins@santafenm.gov (ajhopkins@santafenm.gov) for signature. One of them to sign
2025-01-21 - 9:58:11 PM GMT

 Email viewed by ALEXIS LOTERO (aclotero@santafenm.gov)
2025-01-21 - 9:58:42 PM GMT- IP address: 104.47.64.254

 Document e-signed by ALEXIS LOTERO (aclotero@santafenm.gov)
Signature Date: 2025-01-21 - 10:02:24 PM GMT - Time Source: server- IP address: 63.232.20.2

 Document sent to JoAnn Lovato (jdlovato@santafenm.gov) and Travis Dutton-Leyda
(tkduttonleyda@santafenm.gov) for signature. One of them to sign
2025-01-21 - 10:02:29 PM GMT

 Email viewed by Travis Dutton-Leyda (tkduttonleyda@santafenm.gov)
2025-01-22 - 3:10:29 PM GMT- IP address: 98.97.112.124

 Document e-signed by Travis Dutton-Leyda (tkduttonleyda@santafenm.gov)
Signature Date: 2025-01-22 - 3:17:25 PM GMT - Time Source: server- IP address: 98.97.112.124

 Document emailed to Josie Bolden (jxbolden@santafenm.gov) for signature
2025-01-22 - 3:17:29 PM GMT

 Email viewed by Josie Bolden (jxbolden@santafenm.gov)
2025-01-22 - 4:52:34 PM GMT- IP address: 104.47.65.254



 Document e-signed by Josie Bolden (jxbolden@santafenm.gov)

Signature Date: 2025-01-22 - 4:52:59 PM GMT - Time Source: server- IP address: 63.232.20.2

 Document emailed to EMILY OSTER (ekoster@santafenm.gov) for signature

2025-01-22 - 4:53:05 PM GMT

 Email viewed by EMILY OSTER (ekoster@santafenm.gov)

2025-01-25 - 7:13:32 PM GMT- IP address: 174.218.22.98

 Document e-signed by EMILY OSTER (ekoster@santafenm.gov)

Signature Date: 2025-01-30 - 6:20:42 AM GMT - Time Source: server- IP address: 63.232.20.2

 Agreement completed.

2025-01-30 - 6:20:42 AM GMT