

November 7, 2024

Planning Commission

Case 2023-7752: 4000 & 4200 Beckner Road Meridian Preliminary
Serial Subdivision Plat

ATTACHMENT C

ENN Application



EARLY NEIGHBORHOOD NOTIFICATION MEETING

Request for Staff Attendance

Project Information

Project Name: Las Soleras Meridian Medical Center Subdivision

Address: 4000 & 4200 Beckner Road Parcel Size: 47.83 acres

Zoning: C-2 Future Land Use: Uses allowed in a C-2 District

Preapplication Conference Date: June 22, 2023

Detailed Project Description: Subdivision of Las Soleras Master Plan parcels 18B (18.01 acres) and 18A (29.82 acres) from two to six legal parcels per the attached site plan Exhibit.

18B 18.01 acres Property Owner Information

Name: Santa Fe Las Soleras Medical Development LLC ATTN: Mike Conn

Address: 500 YGNACIO VALLEY ROAD, SUITE 325, WALNUT CREEK, CA 94596

Phone: 925-302-1400 E-mail Address: mconn@mpcca.com

18A 29.82 acres Property Owner Information

Name: Las Soleras Center LLC and Las Soleras Village LLC ATTN: Gordon Skarsgard

Address: 8220 San Pedro NE Suite 120/ Albuquerque, NM 87113

Phone: 505-998-9091 E-mail Address: skip@ziarisingnm.com

Applicant/Agent Information (if different from owner):

Name: Orion West, LLC, ATTN: Brian Nenninger

Address: 2213 Brother's Road, STE#800, Santa Fe, NM 87505

Phone: 832-338-0364 E-mail Address: brian.nenninger@orion-west.com

Agent Authorization (if applicable):

I am/We are the owner(s) and record title holder(s) of the property located at: 4000 & 4200 Beckner Road

I/We authorize Orion West, LLC, Attn: Brian Nenninger to act as my/our agent to execute this application.

Signed: Mike Conn Date: 09/01/2023

Signed: Gordon J. Skarsgard Date: 10/19/2023

Proposed ENN Meeting Dates:

Provide 2 options:	Preferred Option	Alternative
DATE:	15 Nov 2023	21 Nov 2023
TIME:	5:30 pm	5:30 pm
LOCATION:	Zoom	Zoom

(d) RELATIONSHIP TO EXISTING DENSITY AND LAND USE WITHIN THE SURROUNDING AREA AND WITH LAND USES AND DENSITIES PROPOSED BY THE CITY GENERAL PLAN *For example: how are existing City Code requirements for annexation and rezoning, the Historic Districts, and the General Plan and other policies being met.*

The subdivision will not impact currently allowed density or land uses as the zoning remains unchanged and governed by the underlying C-2 general commercial district. All density and land use requirements enforced today will remain enforce upon the creation of the subdivision. In addition, there is a scale and usability advantage to the smaller developments this subdivision will facilitate. Building scale, elevations, and design will echo a modern southwestern desert theme with respect to massing, fenestration, materials, color, texture, shading devices, and lighting. Input from the surrounding community via the Development Plan application process and associated ENNs will be incorporated into each project as development occurs in the subdivision.

(e) EFFECTS ON PARKING, TRAFFIC PATTERNS, CONGESTION, PEDESTRIAN SAFETY, IMPACTS OF THE PROJECT ON THE FLOW OF PEDESTRIAN OR VEHICULAR TRAFFIC AND PROVISION OF ACCESS FOR THE DISABLED, CHILDREN, LOW-INCOME AND ELDERLY TO SERVICES *For example: increased access to public transportation, alternate transportation modes, traffic mitigation, cumulative traffic impacts, pedestrian access to destinations and new or improved pedestrian trails.*

The smaller sites generated by the subdivision is within the baseline analysis for the Las Soleras Master Plan. The subdivision is expected to facilitate the Las Soleras Master Plan by further enhancing pedestrian amenities by expanding the pedestrian trail and sidewalk network envisioned by the Las Soleras Master Plan to enhance connectivity of the area. Street and drive capacity after the implementation of any infrastructure improvements associated with the subdivision is expected to be sufficient for future traffic generated by the development of subdivision parcels. Once the subdivision is created, future development may be subject to further traffic analysis in accordance with the City of Santa Fe's municipal code.

(f) IMPACT ON THE ECONOMIC BASE OF SANTA FE *For example: availability of jobs to Santa Fe residents; market impacts on local businesses; and how the project supports economic development efforts to improve living standards of neighborhoods and their businesses.*

The parcels created by this subdivision are expected to expand on the spillover economic benefits to the community to be realized by the Meridian Medical Office Building. This is by virtue of the high earning employee base projected at occupancy. With respect to the medical office parcel, the number of employees (including physicians, nurses, consultants, contractors, administrative and janitorial) for the Meridian Office project are estimated to peak at 150 full time equivalents. The development of the medical office parcels will conservatively add another seventy-five full-time equivalents upon build out. The development of the four additional parcels will generate other benefits that include construction trade jobs, increased taxes, and development fees, all of which will confer direct and indirect economic benefit to Santa Fe residents. The project's employee base will stimulate the surrounding housing market as well, enhancing the resale value of the existing housing stock. The subdivision will be an important addition to the surrounding community in that it further contributes to the vision of the Las Soleras Master Plan as originally conceived.

(g) EFFECT ON THE AVAILABILITY OF AFFORDABLE HOUSING AND AVAILABILITY OF HOUSING CHOICES FOR ALL SANTA FE RESIDENTS *For example: creation, retention, or improvement of affordable housing; how the project contributes to serving different ages, incomes, and family sizes; the creation or retention of affordable business space.*

The subdivision will generate a variety of uses and an employee mix that is not expected to materially impact the city's affordable housing stock. This said, any future residential development will comply with the City of Santa Fe's affordable housing ordinance.

(h) EFFECT UPON PUBLIC SERVICES SUCH AS FIRE, POLICE PROTECTION, SCHOOL SERVICES AND OTHER PUBLIC SERVICES OR INFRASTRUCTURE ELEMENTS SUCH AS WATER, POWER, SEWER, COMMUNICATIONS, BUS SYSTEMS, COMMUTER OR OTHER SERVICES OR FACILITIES *For example: whether or how the project maximizes the efficient use or improvement of existing infrastructure; and whether the project will contribute to the improvement of existing public infrastructure and services.*

The subdivision will be served by the existing water and sewer infrastructure built to accommodate the uses planned within the Las Soleras Master Plan, as well as the existing fire, police, and emergency services. The site is located on the Santa Fe Trails bus route system. A bus stop is currently within walking distance of the site. However, a new bus stop will be considered as part of this subdivision application.

(i) IMPACTS UPON WATER SUPPLY, AVAILABILITY AND CONSERVATION METHODS *For example: conservation and mitigation measures; efficient use of distribution lines and resources; effect of construction or use of the project on water quality and supplies.*

Development on the created parcels will implement water conservation measures as mandated by City of Santa Fe both domestic and landscape irrigation uses. New development within the subdivision will have to secure and deed water right to the City of Santa Fe as a credit to offset the new water use.

(j) EFFECT ON THE OPPORTUNITIES FOR COMMUNITY INTEGRATION AND SOCIAL BALANCE THROUGH MIXED LAND USE, PEDESTRIAN ORIENTED DESIGN, AND LINKAGES AMONG NEIGHBORHOODS AND RECREATIONAL ACTIVITY AND EMPLOYMENT CENTERS *For example: how the project improves opportunities for community integration and balance through mixed land uses, neighborhood centers and/or pedestrian-oriented design.*

The subdivision will bring commercial/business park uses that will enhance community integration by building out and implementing the vision of the Master Plan, which identifies commercial development for this land. The Master Plan, taken in its totality, provides an integration of residential and commercial land uses to best serve the community. The subdivision is anchored by the Meridian Medical Office project and will be a meaningful 'employment center' within Las Soleras and the Southside of Santa Fe.

(k) EFFECT ON SANTA FE'S URBAN FORM; *For example: how are policies of the existing City General Plan being met? Does the project promote a compact urban form through appropriate infill development? Discuss the project's effect on intra-city travel and between employment and residential centers.*

As it facilitates commercial infill by smaller groups, the proposed subdivision enables the responsible build out of important components of the approved Las Soleras Master Plan. The proximity of the project to residential uses is a mutually symbiotic relationship, allowing employees to potentially live near work, creating important work-life linkages. The subdivision will offer Providers an opportunity to build advanced medical practices serving the greater Santa Fe community.



Santa Fe Public Schools

Property & Asset Management

Residential Development Impact Information Form

School Notification as required by City Ordinance 14-8.18 AFCC 1987

- 1. Project Name: Las Soleras Meridian Medical Center Subdivision
- 2. Location of Property: 4000 and 4200 Beckner Road
- 3. Owner/Agent Name: ORION West LLC
 Mailing Address: PO Box 5744, Santa Fe, NM 87502-5744
 Phone & Fax: 832.338.0364

4. Unit Matrix

PROJECT EFFECT ON STUDENT POPULATION		
Unit Type	Unit Quantity	Average Price
Single Family (detached)	unknown	
Single Family (attached)		
Townhome/ Apartment		
Multi-Family		
Commercial C-2 Subdivision	N/A	

- 5. Elementary School Zone for Proposed Development: Cesar Chavez Elementary
- 6. Middle School Zone for Proposed Development: Ortiz Middle School
- 7. High School Zone for Proposed Development: Capital High School
- 8. Build out Rates (Year/s; #/yr): N/A/C-2 Subdivision Application

Educational Services Center
 610 Alta Vista
 Santa Fe, NM 87505
 Telephone (505) 467-2000
 www.sfps.info

For questions & submittal, contact:
 Santa Fe Public Schools, Property & Asset Management,
 2195 Zia Road, Santa Fe NM 87505
 505 467 3400



ORION West LLC

Development | Land Use | Planning | Project Management
PO Box 5744, Santa Fe, NM 87502-5744

EARLY NEIGHBORHOOD NOTIFICATION MEETING

October ??, 2023

RE: DATE: November ??, 2023

Early Neighborhood Notification (“ENN”) Meeting: 4200 and 4000 Beckner Road, Santa Fe, NM 87507

Dear Neighbor:

This letter is being sent as notice of a neighborhood meeting to discuss the proposed application to the City of Santa Fe (“City”) for approval to subdivide an 18.01-acre parcel known as parcel 18B and a 29.82-acre parcel known as 18A into six legal lots. The parcels are located within the Las Soleras Master Plan and will be home to the now under construction Meridian Office Building. The subject property is located at 4000 and 4200 Beckner Road and is zoned General Commercial (“C-2”). Please refer to the enclosed Vicinity Map and Subdivision Site Plan.

The application to be submitted to the City of Santa Fe will request approval of a “serial subdivision” which will create six successive lots from existing Las Soleras parcels 18B and 18A. Beyond the subdivision, no new Development Plan or related project approvals are being requested with this application.

In accordance with the City’s Early Neighborhood Notification requirements, this is to inform you that an ENN meeting is scheduled for:

Topic: Serial Subdivision of Las Soleras parcels 18B and 18A (4200 and 4000 Beckner Road).

When: November ??, 2023, 5:30 PM Mountain Time

Where: <https://santafe.primegov.com/public/portal>

Early Neighborhood Notification is intended to provide for an exchange of information between prospective applicants for development projects and the project's neighbors before plans become too firm to respond meaningfully to community input. Enclosed, please find a vicinity map and proposed site plan as well as the responses to the ENN criteria. If you have any questions or comments, please contact me.

Persons with disabilities in need of special accommodations, are hearing impaired, or need an interpreter, please contact the Land Use Department, Geraldine Gurule, Project Administrator, at (505) 955-6820 or email at: gagurule@santafenm.gov five (5) days prior to the meeting date.

Regards,

Brian Nenninger, P.E.
Orion West, LLC

Enclosures: ENN Guidelines, Vicinity Map and Site Plan

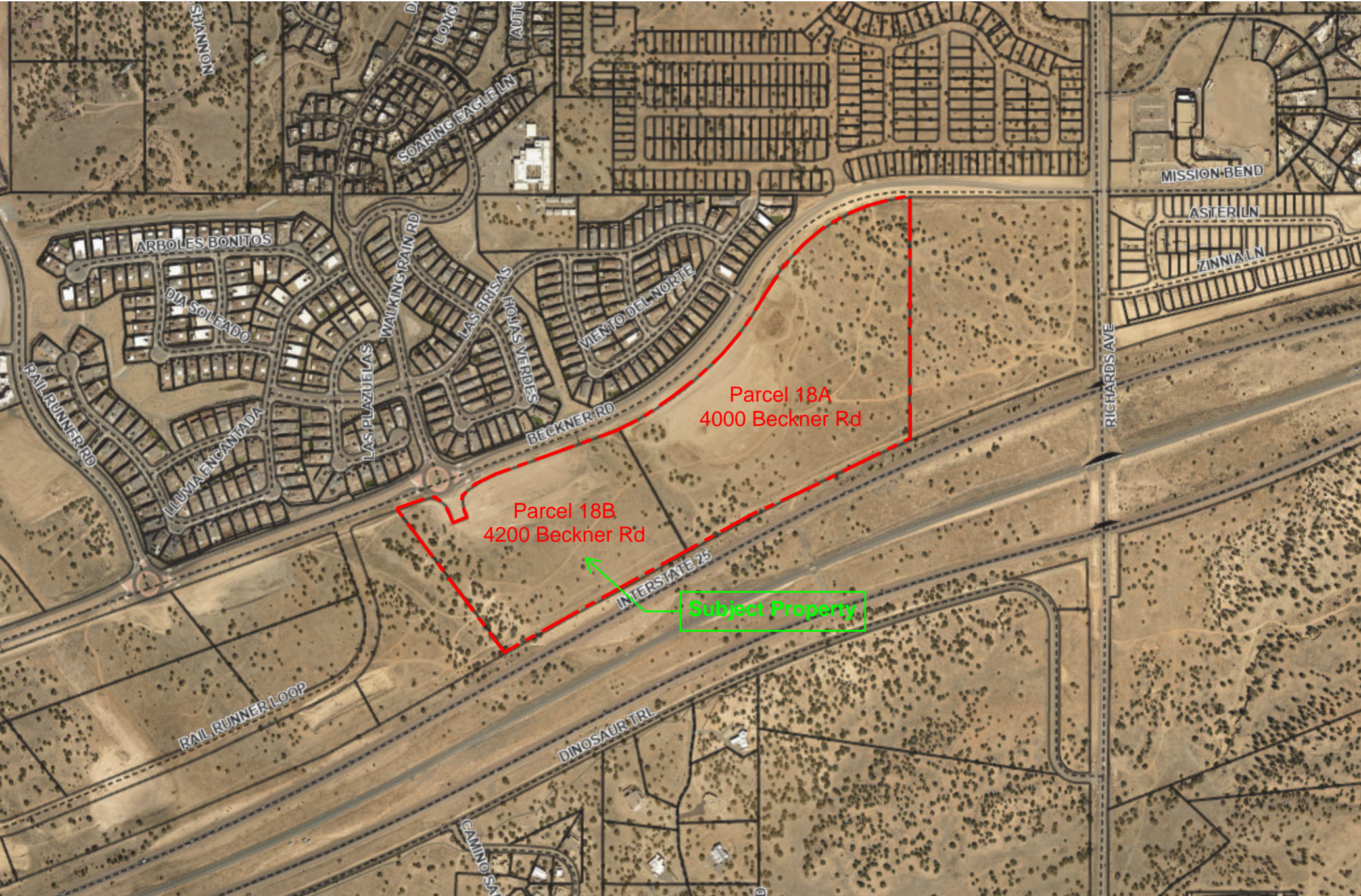

Parcel 18A
4000 Beckner Rd

Parcel 18B
4200 Beckner Rd

Subject Property

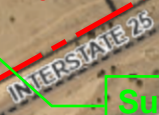

SHANNON

SOARING EAGLE LN

WALKING RAIN RD

LAS BRISAS

HOJAS VERDES

VIENTO DEL NORTE

BECKNER RD

MISSION BEND

ASTER LN

ZINNIA LN

RICHARDS AVE

ARBOLES BONITOS

DIA SOLEADO

LLUVIA ENCANTADA

RAIL RUNNER RD

RAIL RUNNER LOOP

DINOSAUR TRL

CAMINO SAT

Exhibit A: Subdivision Site Plan

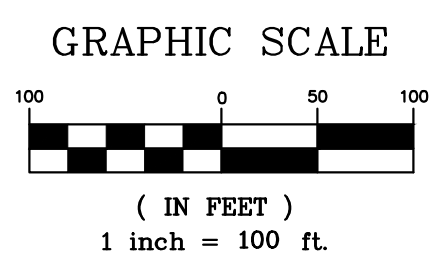
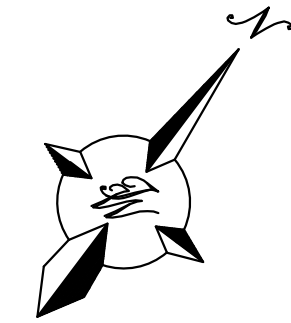
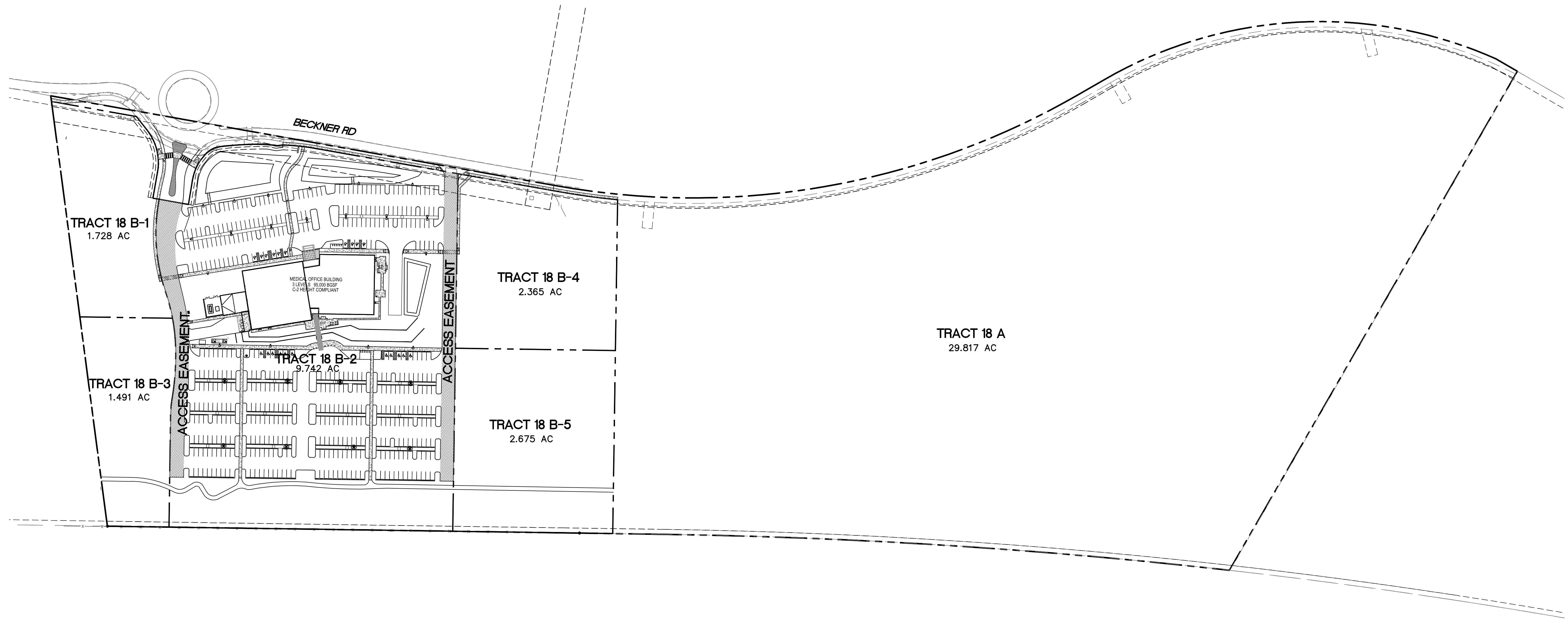

ENGINEER'S SEAL	LAS SOLERAS TRACT 18 B REPLAT BECKNER RD SANTA FE, NM	DRAWN BY pm
	SKETCH PLAT	DATE 10-17-23
RONALD R. BOHANNAN P.E. #7868	 TIERRA WEST, LLC 5571 MIDWAY PARK PL NE ALBUQUERQUE, NEW MEXICO 87109 (505) 858-3100 www.tierrowestllc.com	DRAWING 2022040-SK
		SHEET # 1
		JOB # 2022040

LEGEND:

- DENOTES #4 REBAR NMPLS 13986, OR AS SHOWN, FOUND.
- DENOTES #4 REBAR WITH CAP #13986 TO BE SET UPON RECORDING.
- DENOTES CALCULATED POINT, NOT SET.
- DENOTES UTILITY BOX, PULL BOX OR METER.
- ⊕ DENOTES UTILITY POLE.
- ⊗ DENOTES STORM SEWER MANHOLE.
- OH— DENOTES OVERHEAD UTILITY LINE.
- DENOTES EASEMENT VACATED BY THIS PLAT.
- x- DENOTES FENCELINES.
- DENOTES BOUNDARY OF LANDS DEALT WITH BY THIS PLAT. INFORMATION OUTSIDE OF THIS BOUNDARY IS BACKGROUND INFORMATION ONLY, NOT VERIFIED FOR ACCURACY AND IS NOT PART OF THIS PLAT. DATA IN PARENTHESIS IS FROM PREVIOUS PLATS OR DOCUMENTS.

CONTROL SUMMARY:

BEARINGS ARE GRID. DISTANCES ARE REFERRED TO 6800' AMSL. TO CONVERT TO NMSPC CENTRAL ZONE GRID DISTANCES, MULTIPLY BY THE COMBINED SCALE FACTOR OF 0.999583883. VERTICAL DATUM IS NAVD88. ALL DATA IS DERIVED FROM CONTROL ESTABLISHED USING THE NMSP NAD83 PROJECTION FROM THE CARLSON SURVEY2 DATA COLLECTION PROGRAM USING RTK BASE STATION "DAWSON2", ESTABLISHED FROM '92 NGS AND SANTA FE COUNTY G.I.S. CONTROL STATIONS: GRID N1687626.87027, GRID E 1708833.475 AND AN ELEVATION OF 6572.376 VIA STATIC OBSERVATION. A BEARING OF S60°50'03"W WAS ESTABLISHED ON THE SOUTH BOUNDARY BETWEEN NMSHD R/W RAIL

LINE	BEARING	DIST.
L1	N68°11'50"W	34.42'
L2	N19°55'24"W	53.23'
L3	S70°04'36"W	72.00'
L4	S20°32'01"E	49.22'
L5	S08°51'27"W	16.53'
L6	S70°18'02"W	17.92'
L7	S52°31'39"W	13.10'

CURVE	RADIUS	ARC	CHORD	BEARING	DELTA
C1	1549.00'	961.23'	945.88'	N47°49'25"E	35°33'17"
C2	851.00'	849.49'	814.65'	N58°38'36"E	57°11'38"
C3	105.00'	88.47'	85.87'	N44°03'37"W	48°16'28"
C4	65.00'	40.73'	40.07'	S09°05'44"E	35°54'20"
C5	45.00'	34.57'	33.73'	S30°52'05"W	44°01'17"
C6	663.00'	95.45'	95.36'	S57°00'10"W	8°14'54"
C7	476.02'	66.75'	66.69'	S66°03'35"W	8°02'02"
C8	1548.99'	121.00'	120.97'	S67°50'20"W	4°28'32"

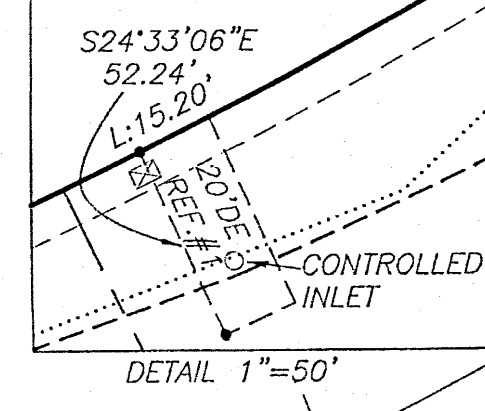
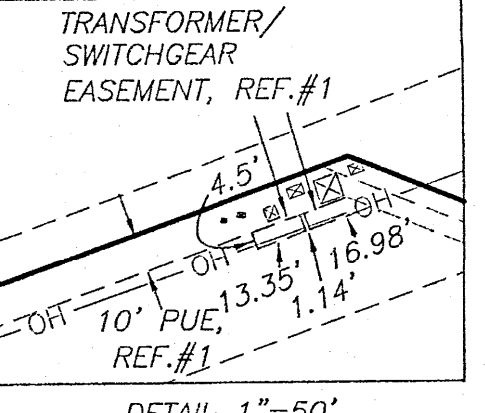
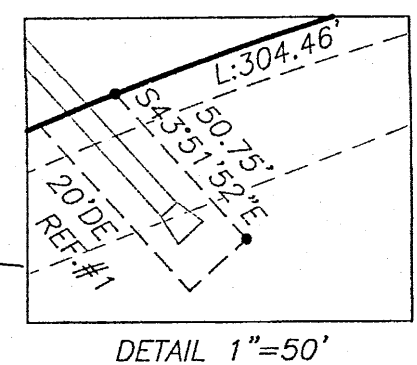
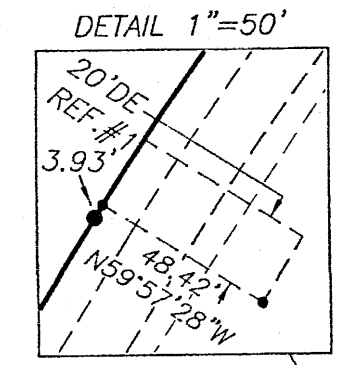

ESTANCIAS DE LAS SOLERAS UNIT 1A & 1B
PLAT 814/39-43

ESTANCIAS DE LAS SOLERAS UNIT 2A
PLAT 823/37-39

TRACT 18A
29.817 Ac.±
26.791 Ac.± w/o OPEN SPACE
#4000 BECKNER ROAD

TRACT 18B
18.001 Ac.±
15.797 Ac.± w/o OPEN SPACE
#4200 BECKNER ROAD

TRACT 19 LAS SOLERAS
PLAT 809/3-4

INTERSTATE 25
RIGHT OF WAY MAP
NEW MEXICO PROJECT NO. 1-025-5(36)272
JUNE 18, 1971

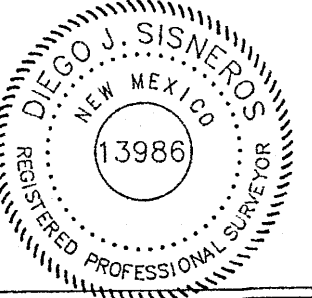
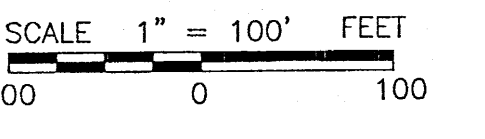

Diego J. Sisneros
DIEGO J. SISNEROS, NMPS#13986 11/1/2022

Parcels within 300ft. of 4200 Beckner - Lot 18B

Parcel Number	UPC	Property Address	Legal Description	Owner Name	Mailing Address	City	State	Zip
99304000	1.05009E+18	5001 RAIL RUNNER RD	S17 T16N R9E LAS SOLERAS 19	LAS SOLERAS CENTER LLC	8220 SAN PEDRO NE STE 500	ALBUQUERQUE	NM	87113-2476
99307860	1.05009E+18	4735 HOJAS VERDES	S18 T16N R9E ESTANCIAS DE LAS SOLERAS UNIT 1A 43	LOVE, JEFFREY & PATRICIA YVONNE ROSAS	4735 HOJAS VERDES	SANTA FE	NM	87507
99307863	1.05009E+18	4727 HOJAS VERDES	S18 T16N R9E ESTANCIAS DE LAS SOLERAS UNIT 1A 39	MARTINEZ, JESSE L	4727 HOJAS VERDES	SANTA FE	NM	87507-0853
99307838	1.05009E+18	4716 LAS PLAZUELAS	LOT 18, UNIT 1-B, ESTANCIAS DE LAS SOLERAS S/D, S18 T16N R9E	TORRES, FELISHA JOSEPHINE	NM 434 HOUSE 1463	GUADALUPITA	NM	87722
99307840	1.05009E+18	4720 LAS PLAZUELAS	S18 T16N R9E ESTANCIAS DE LAS SOLERAS UNIT 1B 1E	MARTIN, BILLY L & PATRICIA M	4720 LAS PLAZUELAS	SANTA FE	NM	87507-0848
99307837	1.05009E+18	4714 LAS PLAZUELAS	S18 T16N R9E ESTANCIAS DE LAS SOLERAS UNIT 1B 1E	BODE, RAJESH & GAYATRI ATLURI	4714 LAS PLAZUELAS	SANTA FE	NM	87507-0848
99309000	1.05009E+18	4736 VIENTO DEL NORTE	S18 T16N R9E ESTANCIAS DE LAS SOLERAS UNIT 2A 1E	ARCHIBEQUE, JOLENE N & JUSTIN P SCHACHTNER	4736 VIENTO DEL NORTE	SANTA FE	NM	87507-0866
99307846	1.05009E+18	4722 LAS PLAZUELAS	S18 T16N R9E ESTANCIAS DE LAS SOLERAS UNIT 1B PARCEL A2	PULTE HOMES OF NEW MEXICO, INC	7601 JEFFERSON ST NE STE 32C	ALBUQUERQUE	NM	87109
99303987	1.05009E+18	4354 BECKNER RD	S17 T16N R9E LAS SOLERAS 24	EAKIN, D W & H H TRICKEY	8220 SAN PEDRO DR NE #500	ALBUQUERQUE	NM	87113
99308473	1.05009E+18	4710 LAS PLAZUELAS	S18 T16N R9E ESTANCIAS DE LAS SOLERAS UNIT 1C 3C	LILLIEMAE G ORTIZ REVOCABLE TRUST	4710 LAS PLAZUELAS	SANTA FE	NM	87507-0848
99307878	1.05009E+18	4715 HOJAS VERDES	S18 T16N R9E ESTANCIAS DE LAS SOLERAS UNIT 1A 33	HEINRICH, ERIC J	4715 HOJAS VERDES	SANTA FE	NM	87507-0853
99307873	1.05009E+18	4716 HOJAS VERDES	S18 T16N R9E ESTANCIAS DE LAS SOLERAS UNIT 1A 53	DARWIN, DWAYNE ROBERT & NAOMI RUTH	4716 HOJAS VERDES	SANTA FE	NM	87507
99308998	1.05009E+18	4734 VIENTO DEL NORTE	S18 T16N R9E LOT 17 ESTANCIAS DE LAS SOLERAS UNIT 2A	MONTOYA, MARK A & ANGELA C ROGUE-DELGADILLO	4734 VIENTO DEL NORTE	SANTA FE	NM	87507-0866
99308991	1.05009E+18	4726 VIENTO DEL NORTE	S18 T16N R9E ESTANCIAS DE LAS SOLERAS UNIT 2A 1E	THOMAS, GRANT HIRAM	4726 VIENTO DEL NORTE	SANTA FE	NM	87507-0862
99307861	1.05009E+18	4731 HOJAS VERDES	S18 T16N R9E ESTANCIAS DE LAS SOLERAS UNIT 1A 41	BROOKS, DANIEL JOSEPH & DESIREE N	4731 HOJAS VERDES	SANTA FE	NM	87507-0853
99304001	1.05009E+18	4000 BECKNER RD	S17 T16N R9E LAS SOLERAS 18	EAKIN, D W & H H TRICKEY	8220 SAN PEDRO DR NE #500	ALBUQUERQUE	NM	87113
99307872	1.05009E+18	4717 HOJAS VERDES	S18 T16N R9E ESTANCIAS DE LAS SOLERAS UNIT 1A 34	GRIEGO, BERYL A & MAX J	4717 HOJAS VERDES	SANTA FE	NM	87507
99309024	1.05009E+18	UNASSIGNED	S18 T16N R9E ESTANCIAS DE LAS SOLERAS UNIT 2A PARCEL F1	PULTE HOMES OF NEW MEXICO INC	7601 JEFFERSON ST NE STE 32C	ALBUQUERQUE	NM	87109-4496
99308992	1.05009E+18	4724 VIENTO DEL NORTE	S18 T16N R9E ESTANCIAS DE LAS SOLERAS UNIT 2A 12	ALABWEH, HUSAM F	4724 VIENTO DEL NORTE	SANTA FE	NM	87507-0866
99307859	1.05009E+18	4733 HOJAS VERDES	S18 T16N R9E ESTANCIAS DE LAS SOLERAS UNIT 1A 42	JARAMILLO, ANGELA M & SANTIAGO J	PO BOX 1408	LOS ALAMOS	NM	87544-1408
99308994	1.05009E+18	4728 VIENTO DEL NORTE	S18 T16N R9E ESTANCIAS DE LAS SOLERAS UNIT 2A 14	NOLL, JOSEPH & JAMIE	4728 VIENTO DEL NORTE	SANTA FE	NM	87507-0866
99308993	1.05009E+18	4624 VIENTO DEL NORTE	S18 T16N R9E ESTANCIAS DE LAS SOLERAS UNIT 2A PARCEL G1	PULTE HOMES OF NEW MEXICO INC	7601 JEFFERSON ST NE STE 32C	ALBUQUERQUE	NM	87109-4496
99307869	1.05009E+18	4719 HOJAS VERDES	S18 T16N R9E ESTANCIAS DE LAS SOLERAS UNIT 1A 3E	RASHID, AIMAN & WAFFAH	4719 HOJAS VERDES	SANTA FE	NM	87507-0853
99308995	1.05009E+18	4730 VIENTO DEL NORTE	S18 T16N R9E ESTANCIAS DE LAS SOLERAS UNIT 2A 1E	SINGLEDECKER, STEVEN J & AMALIA	4730 VIENTO DEL NORTE	SANTA FE	NM	87507
99307871	1.05009E+18	4718 HOJAS VERDES	S18 T16N R9E ESTANCIAS DE LAS SOLERAS UNIT 1A 54	GARCIA, JESSICA S & JAMES E	4718 HOJAS VERDES	SANTA FE	NM	87507
99307867	1.05009E+18	4721 HOJAS VERDES	S18 T16N R9E LOT 36 ESTANCIAS DE LAS SOLERAS UNIT 1A	GARCIA, MAURICIO & CAREN G	4721 HOJAS VERDES	SANTA FE	NM	87507-0853
99307864	1.05009E+18	4737 HOJAS VERDES	S18 T16N R9E ESTANCIAS DE LAS SOLERAS UNIT 1A 44	LONGLEY, THOMAS W & GUADALUPE	4737 HOJAS VERDES	SANTA FE	NM	87507-0853
99307866	1.05009E+18	4723 HOJAS VERDES	S18 T16N R9E ESTANCIAS DE LAS SOLERAS UNIT 1A 37	FRESQUEZ, MARGARET	4723 HOJAS VERDES	SANTA FE	NM	87507
99308489	1.05009E+18	UNASSIGNED	S18 T16N R9E ESTANCIAS DE LAS SOLERAS UNIT 1C PARCEL B1	PULTE HOMES OF NEW MEXICO, INC	7601 JEFFERSON ST NE STE 32C	ALBUQUERQUE	NM	87109
99307865	1.05009E+18	4725 HOJAS VERDES	S18 T16N R9E ESTANCIAS DE LAS SOLERAS UNIT 1A 3E	MONTOYA, NAOMI J	PO BOX 15734	SANTA FE	NM	87592-5734
99307903	1.05009E+18	4701 A LAS BRISAS	S18 T16N R9E ESTANCIAS DE LAS SOLERAS UNIT 1A PARCEL B1	PULTE HOMES OF NEW MEXICO, INC	7601 JEFFERSON ST NE STE 32C	ALBUQUERQUE	NM	87109
99309002	1.05009E+18	4719 VIENTO DEL NORTE	S18 T16N R9E ESTANCIAS DE LAS SOLERAS UNIT 2A 6C	SMARZEWSKI, JOHN S & JODI KAY DAVIS	4719 VIENTO DEL NORTE	SANTA FE	NM	87507
99308996	1.05009E+18	4732 VIENTO DEL NORTE	S18 T16N R9E ESTANCIAS DE LAS SOLERAS UNIT 2A 1E	JO, YONG I & MYONG	4732 VIENTO DEL NORTE	SANTA FE	NM	87507-0866
99307862	1.05009E+18	4729 HOJAS VERDES	S18 T16N R9E ESTANCIAS DE LAS SOLERAS UNIT 1A 4C	DE LA TORRE RAMOS, ALMA CAROLINA	4729 HOJAS VERDES	SANTA FE	NM	87507
99308997	1.05009E+18	4722 VIENTO DEL NORTE	S18 T16N R9E LOT 11 ESTANCIAS DE LAS SOLERAS UNIT 2A	REILLY, TERRENCE J & KIMBERLY	4722 VIENTO DEL NORTE	SANTA FE	NM	87507-0866
99307836	1.05009E+18	4712 LAS PLAZUELAS	S18 T16N R9E ESTANCIAS DE LAS SOLERAS UNIT 1B 2C	ROMERO, MARIO R	4712 LAS PLAZUELAS	SANTA FE	NM	87507
99307839	1.05009E+18	4718 LAS PLAZUELAS	LOT 17, 0.1898 AC, ESTANCIAS DE LAS SOLERAS UNIT 1-B S/D, S18 T16N R9E	ALRAMINI, HUSSEIN & RUBA TANASH	4718 LAS PLAZUELAS	SANTA FE	NM	87507-0848

Parcels within 300ft. of 4000 Beckner - Lot 18A

Parcel Number	UPC	Property Address	Legal Description	Owner Name	Mailing Address	City	State	Zip
99309030	1.05009E+18	4754 VIENTO DEL NORTE	LOT 27, UNIT 2A, 0.1588 AC, ESTANCIAS DE LAS SOLERAS S/D, S18 T16N R9E	DUFFEK FAMILY REVOCABLE TRUST	42313 N LONG COVE WAY	ANTHEM	AZ	85086-1250
99309007	1.05009E+18	4742 VIENTO DEL NORTE	S18 T16N R9E UNIT 2A LOT 21 ESTANCIAS DE LAS SOLERAS	QUINTANA, EUTIMIO A & DIANE M	4742 VIENTO DEL NORTE	SANTA FE	NM	87507-0866
99309052	1.05009E+18	4760 VIENTO DEL NORTE	LOT 30, ESTANCIAS DE LAS SOLERAS, UNIT 2A, S18 T16N R9E	KALOGERINI, DANIEL & ERIN LARSEN	4760 VIENTO DEL NORTE	SANTA FE	NM	87507-0866
910008932	1.0501E+18	3800 GOVERNOR MILES RD	LOT 3A T16N R 9E S 8 94.07 AC	BUILDING SERVICES OF SANTA FE	PO BOX 4496	SANTA FE	NM	87502
99309000	1.05009E+18	4736 VIENTO DEL NORTE	S18 T16N R9E ESTANCIAS DE LAS SOLERAS UNIT 2A 18	ARCHIBEQUE, JOLENE N & JUSTIN P SCHACHTNER	4736 VIENTO DEL NORTE	SANTA FE	NM	87507-0866
99309013	1.05009E+18	4746 VIENTO DEL NORTE	LOT 23, UNIT 2A, 0.146 AC, ESTANCIAS DE LAS SOLERAS, S18 T16N R9E	BALDWIN, FRANK LYNN	4746 VIENTO DEL NORTE	SANTA FE	NM	87507-0866
99309017	1.05009E+18	4748 VIENTO DEL NORTE	LOT 24, UNIT 2A, ESTANCIAS DE LAS SOLERAS. S18 T16N R9E	ORTEGA, IVETTE	4748 VIENTO DEL NORTE	SANTA FE	NM	87507-0866
99309028	1.05009E+18	4752 VIENTO DEL NORTE	LOT 26 S18 T16N R9E ESTANCIAS DE LAS SOLERAS UNIT 2A	MARTINEZ, JOHANNA M	4752 VIENTO DEL NORTE	SANTA FE	NM	87507-0866
99309011	1.05009E+18	4744 VIENTO DEL NORTE	S18 T16N R9E ESTANCIAS DE LAS SOLERAS UNIT 2A 22	MATA, ROSALIE A	4744 VIENTO DEL NORTE	SANTA FE	NM	87507-0866
99309074	1.05009E+18	4772 VIENTO DEL NORTE	LOT 36, UNIT 2A, 0.1812 AC, ESTANCIAS DE LAS SOLERAS S/D, S18 T16N R9E	ROYBAL, DARLENE MELISSA & DAVID LAWRENCE	4772 VIENTO DEL NORTE	SANTA FE	NM	87507-0866
99308998	1.05009E+18	4734 VIENTO DEL NORTE	S18 T16N R9E LOT 17 ESTANCIAS DE LAS SOLERAS UNIT 2A	MONTOYA, MARK A & ANGELA C ROGUE-DELGADILLO	4734 VIENTO DEL NORTE	SANTA FE	NM	87507-0866
99309039	1.05009E+18	4751 VIENTO DEL NORTE	S18 T16N R9E LOT 76 ESTANCIAS DE LAS SOLERAS UNIT 2A	BASSETT, FRANCES & JOHN A HANSEN	4751 VIENTO DEL NORTE	SANTA FE	NM	87507-0867
99309071	1.05009E+18	4770 VIENTO DEL NORTE	S18 T16N R9E LOT 35 ESTANCIAS DE LAS SOLERAS UNIT 2A	RASHID, NOOR	4770 VIENTO DEL NORTE	SANTA FE	NM	87507-0866
99308991	1.05009E+18	4726 VIENTO DEL NORTE	S18 T16N R9E ESTANCIAS DE LAS SOLERAS UNIT 2A 13	THOMAS, GRANT HIRAM	4726 VIENTO DEL NORTE	SANTA FE	NM	87507-0862
99304001	1.05009E+18	4000 BECKNER RD	S17 T16N R9E LAS SOLERAS 18	EAKIN, D W & H H TRICKEY	8220 SAN PEDRO DR NE #500	ALBUQUERQUE	NM	87113
99309056	1.05009E+18	4762 VIENTO DEL NORTE	LOT 31, UNIT 2A, ESTANCIAS DE LAS SOLERAS, S18 T16N R9E	WEBBER, KIRK W	4762 VIENTO DEL NORTE	SANTA FE	NM	87507-0866
99309041	1.05009E+18	4756 VIENTO DEL NORTE	S18 T16N R9E ESTANCIAS DE LAS SOLERAS UNIT 2A 28	REIFEL, LOYD J & CONSTANCE E	4756 VIENTO DEL NORTE	SANTA FE	NM	87507-0866
99307872	1.05009E+18	4717 HOJAS VERDES	S18 T16N R9E ESTANCIAS DE LAS SOLERAS UNIT 1A 34	GRIEGO, BERYL A & MAX J	4717 HOJAS VERDES	SANTA FE	NM	87507
99309020	1.05009E+18	4713 BIENVENIDO A CASA	S18 T16N R9E ESTANCIAS DE LAS SOLERAS UNIT 2A 74	WEHNER, THOMAS R & BARBARA LANGE	4713 BIENVENIDO A CASA	SANTA FE	NM	87507-1303
99309024	1.05009E+18	UNASSIGNED	S18 T16N R9E ESTANCIAS DE LAS SOLERAS UNIT 2A PARCEL F1	PULTE HOMES OF NEW MEXICO INC	7601 JEFFERSON ST NE STE 32C	ALBUQUERQUE	NM	87109-4496
99308992	1.05009E+18	4724 VIENTO DEL NORTE	S18 T16N R9E ESTANCIAS DE LAS SOLERAS UNIT 2A 12	ALABWEH, HUSAM F	4724 VIENTO DEL NORTE	SANTA FE	NM	87507-0866
99309059	1.05009E+18	4764 VIENTO DEL NORTE	S18 T16N R9E ESTANCIAS DE LAS SOLERAS UNIT 2A 32	ARNOLD, DANIEL W & MELANIE W	4764 VIENTO DEL NORTE	SANTA FE	NM	87507-0866
99309035	1.05009E+18	4749 VIENTO DEL NORTE	S18 T16N R9E LOT 75 ESTANCIAS DE LAS SOLERAS UNIT 2A	BENNETT, GARY E & APRIL JEAN	4749 VIENTO DEL NORTE	SANTA FE	NM	87507-0867
99309055	1.05009E+18	4104 VIENTO DEL NORTE	S18 T16N R9E ESTANCIAS DE LAS SOLERAS UNIT 2A PARCEL E1	PULTE HOMES OF NEW MEXICO INC	7601 JEFFERSON ST NE STE 32C	ALBUQUERQUE	NM	87109-4496
99303994	1.05009E+18	3750 BECKNER RD	S17 T16N R9E LAS SOLERAS 17	EAKIN, D W & H H TRICKEY	8220 SAN PEDRO DR NE #500	ALBUQUERQUE	NM	87113
99308994	1.05009E+18	4728 VIENTO DEL NORTE	S18 T16N R9E ESTANCIAS DE LAS SOLERAS UNIT 2A 14	NOLL, JOSEPH & JAMIE	4728 VIENTO DEL NORTE	SANTA FE	NM	87507-0866
99309001	1.05009E+18	4738 VIENTO DEL NORTE	S18 T16N R9E ESTANCIAS DE LAS SOLERAS UNIT 2A 19	WEIDNER, KEVIN WAYNE & JANICE RAYE	4738 VIENTO DEL NORTE	SANTA FE	NM	87507-0866
99309068	1.05009E+18	4768 VIENTO DEL NORTE	S18 T16N R9E LOT 34 ESTANCIAS DE LAS SOLERAS UNIT 2A	ALVAREZ, SALVADOR & YVONNE GARLEY	4768 VIENTO DEL NORTE	SANTA FE	NM	87507-0866
99308993	1.05009E+18	4624 VIENTO DEL NORTE	S18 T16N R9E ESTANCIAS DE LAS SOLERAS UNIT 2A PARCEL G1	PULTE HOMES OF NEW MEXICO INC	7601 JEFFERSON ST NE STE 32C	ALBUQUERQUE	NM	87109-4496
99307869	1.05009E+18	4719 HOJAS VERDES	S18 T16N R9E ESTANCIAS DE LAS SOLERAS UNIT 1A 35	RASHID, AIMAN & WAFFAH	4719 HOJAS VERDES	SANTA FE	NM	87507-0853
99308995	1.05009E+18	4730 VIENTO DEL NORTE	S18 T16N R9E ESTANCIAS DE LAS SOLERAS UNIT 2A 15	SINGLEDECKER, STEVEN J & AMALIA	4730 VIENTO DEL NORTE	SANTA FE	NM	87507
99309065	1.05009E+18	4766 VIENTO DEL NORTE	S18 T16N R9E LOT 33 ESTANCIAS DE LAS SOLERAS UNIT 2A	KIRPES, PAUL N	4766 VIENTO DEL NORTE	SANTA FE	NM	87507-0866
99309073	1.05009E+18	4676 VIENTO DEL NORTE	S18 T16N R9E ESTANCIAS DE LAS SOLERAS UNIT 2A PARCEL D1	PULTE HOMES OF NEW MEXICO INC	7601 JEFFERSON ST NE STE 32C	ALBUQUERQUE	NM	87109-4496
99309004	1.05009E+18	4740 VIENTO DEL NORTE	LOT 20, UNIT 2A, 0.146 AC, ESTANCIAS DE LAS SOLERAS, S18 T16N R9E	WOODS, STEPHEN	4740 VIENTO DEL NORTE	SANTA FE	NM	87507-0862
99309022	1.05009E+18	4750 VIENTO DEL NORTE	S18 T16N R9E ESTANCIAS DE LAS SOLERAS UNIT 2A 25	TRUJILLO, JAIME & JESSICA A	4750 VIENTO DEL NORTE	SANTA FE	NM	87507-0866
99309048	1.05009E+18	4758 VIENTO DEL NORTE	S18 T16N R9E ESTANCIAS DE LAS SOLERAS UNIT 2A 29	POTEAT, NORMAN D	4758 VIENTO DEL NORTE	SANTA FE	NM	87507-0866
99309008	1.05009E+18	4716 BIENVENIDO A CASA	S18 T16N R9E LOT 61 ESTANCIAS DE LAS SOLERAS UNIT 2A	WELLS, STEVEN R & DEBORAH A POELKER	4716 BIENVENIDO A CASA	SANTA FE	NM	87507-1302
99309069	1.05009E+18	4135 LAS BRISAS	S18 T16N R9E ESTANCIAS DE LAS SOLERAS UNIT 2A 38	ROMERO, CHRIS P & CYNTHIA L	4135 LAS BRISAS	SANTA FE	NM	87507-0864
99307903	1.05009E+18	4701 A LAS BRISAS	S18 T16N R9E ESTANCIAS DE LAS SOLERAS UNIT 1A PARCEL B1	PULTE HOMES OF NEW MEXICO, INC	7601 JEFFERSON ST NE STE 32C	ALBUQUERQUE	NM	87109
99309002	1.05009E+18	4719 VIENTO DEL NORTE	S18 T16N R9E ESTANCIAS DE LAS SOLERAS UNIT 2A 6C	SMARZEWSKI, JOHN S & JODI KAY DAVIS	4719 VIENTO DEL NORTE	SANTA FE	NM	87507
99308996	1.05009E+18	4732 VIENTO DEL NORTE	S18 T16N R9E ESTANCIAS DE LAS SOLERAS UNIT 2A 16	JO, YONG I & MYONG	4732 VIENTO DEL NORTE	SANTA FE	NM	87507-0866
99309047	1.05009E+18	4753 VIENTO DEL NORTE	S18 T16N R9E LOT 77 ESTANCIAS DE LAS SOLERAS UNIT 2A	CANDELARIA, LEANNA	4753 VIENTO DEL NORTE	SANTA FE	NM	87507-0867
99308997	1.05009E+18	UNASSIGNED	S18 T16N R9E LOT 11 ESTANCIAS DE LAS SOLERAS UNIT 2A	REILLY, TERENCE J & KIMBERLY	4722 VIENTO DEL NORTE	SANTA FE	NM	87507-0866